



PREMIER® X OUTDOOR SPLIT HEAT PUMP WATER HEATER

The Premier X Outdoor Split Heat Pump Water Heater from State is the most adaptable option for consumers who want to save money on their utility bills.* The Premier X split system design allows the heat pump and storage tank to be installed in a wide range of space constrained locations. The Premier X utilizes CO₂ refrigerant allowing the unit to work in colder temperatures compared to a standard heat pump water heater and provides annual savings up to \$600.

HOW DO THEY WORK?

- Absorbs ambient heat from the surrounding air to heat water using a compressor
- Water split system for easy installation by plumber (no EPA Section 608- Type II certification required for handling refrigerants - the HP comes pre-charged ready to go)
- Self-contained heat pump unit is separate from the storage tank
- Various tank sizes available to fit in a large range of space constrained environments previously not fit for standard hybrid heat pump

EXCEPTIONAL ENERGY EFFICIENCY

- Improved efficiency up to 3.80 Uniform Energy Factor (UEF) can reduce the cost of water heating by up to 76% compared to standard electric water heaters
- Heat Pump can operate in ambient temperatures down to -25°F and up to 109°F for more days of high efficiency operation
- ENERGY STAR® certified for many state and local utility rebates

SUSTANABLE REFRIGERATION

- Utilizes CO₂ refrigerant for a smaller carbon footprint
- 99.9% lower global warming potential than the standard refrigerant used in other residential heat pump water heaters

FLEXIBLE CONFIGURATION

- Self-contained heat pump is installed outside
- Up to 66 feet of 1/2 inch water line is piped to storage tank inside
- Tanks are available in a large assortment of sizes and shapes to fit into a variety of space constrained locations
- Ideal for closet, garage, utility room, or basement installation

SMART CONNECTIVITY

- Monitor and control your water heater through the free iCOMM™ App
- Connect through a local Wi-Fi network or directly to the water heater through Bluetooth
- If applicable, download the Time of Use (TOU) schedule of your local electric utility to prioritize heating when the rates are the most affordable
- Receive alerts and notifications

ADVANCED PROTECTION TECHNOLOGY

- Smart sensor leak detection provides early warning and damage prevention
- Built-in freeze defense through heat pump circulation; optional Anti-Freeze Valve Kit available for additional protection during power outages
- Compatible with the automatic water shutoff valve for enhanced protection

10-YEAR LIMITED WARRANTY

- For complete information, consult written warranty or go to statewaterheaters.com

*Comparing 80-gallon Premier X heat pump against pre-2015 similarly-sized standard electric using DOE EF to UEF conversion rates and \$0.14 per kWh electricity cost. Savings may vary.



SOLID. STATE.



COMMERCIAL-GRADE

Residential Electric Water Heaters

HEAT PUMP - A SYSTEM IS A COMBINATION OF HEAT PUMP AND A TANK

| Model Number | Wattage | Dimensions (in.) | | | | Weight (lbs.) | Warranty Term (Years) |
|--------------|---------|------------------|----|--------|-------|---------------|-----------------------|
| | | A | B | C | D | | |
| SHPC0-45 | 4.5 kW | 26-1/2 | 35 | 14-1/2 | 6-1/2 | 114 | 10 |

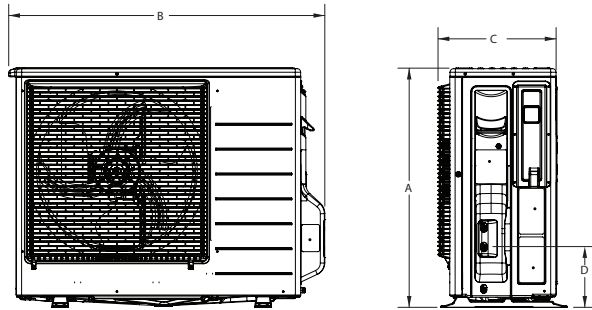

TANK

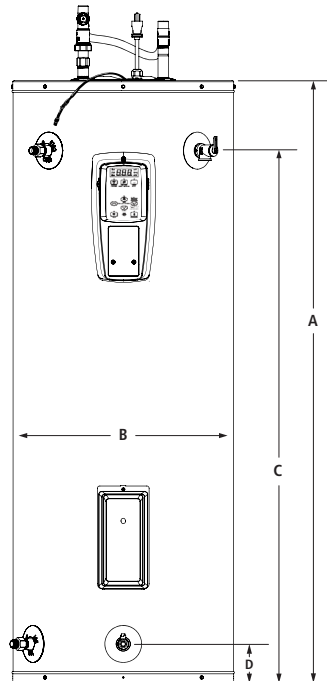

| Model Number | Nominal Capacity | Rated Storage Volume | UEF | First Hour Rating (Gallons) | Dimensions (in.) | | | | Weight (lbs.) | Warranty Term (Years) |
|--------------|------------------|----------------------|------|-----------------------------|------------------|--------|--------|-------|---------------|-----------------------|
| | | | | | A | B | C | D | | |
| SXST-50TG* | 50 | 48 | 3.55 | 72 | 35-7/8 | 26-1/2 | - | 3-7/8 | 158 | 10 |
| SXST-50S | 50 | 46 | 3.52 | 70 | 48-7/8 | 22 | 40-3/4 | 4 | 119 | 10 |
| SXST-50T | 50 | 45 | 3.52 | 67 | 58 | 20 | 51-5/8 | 4 | 115 | 10 |
| SXST-66 | 66 | 60 | 3.70 | 82 | 60-1/4 | 22 | 53-1/4 | 4 | 134 | 10 |
| SXST-80 | 80 | 73 | 3.80 | 95 | 60-1/4 | 24 | 52-1/8 | 4 | 179 | 10 |

*Only available in top T&P

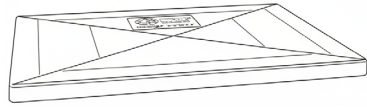
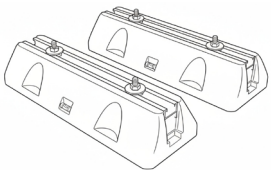
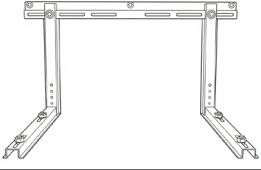

FOR MORE INFORMATION ON CALL 1-800-365-0024. STATE WATER HEATERS RESERVES THE RIGHT TO MAKE PRODUCT CHANGES OR IMPROVEMENTS WITHOUT PRIOR NOTICE.

ACCESSORY LIST

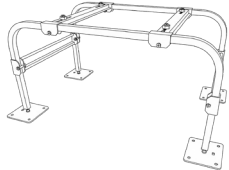
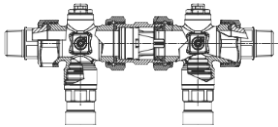
| Model Number | Description | Image |
|--------------|--|---|
| 100400748 | Plastic Equipment Pad 18in X 38in X 3in |  |
| 100400749 | Mounting Struts 17.7in |  |
| 100400750 | Mounting Wall Bracket with Rail, Steel |  |
| 100400761 | Mounting Roof Bracket |  |
| 100400762 | Mounting Stand Aluminum 18in |  |
| 100394673 | Anti-Freeze Valve |  |

OPERATING MODES

- Heat Pump: Maximum energy efficiency
- Guest: Provides maximum hot water for up to seven days
- Vacation: Reduce energy use while you are away
- Quietest Operation: 40dBA outside; 0dBA inside the home

OPERATING REQUIREMENTS

- 208/240 VAC 60Hz single phase 20 amp power supply required for Heat Pump
- 120 VAC 60Hz single phase 15 amp shared circuit required for Storage Tank

OTHER FEATURES

- Outdoor rated communication cable standard on every unit
- Environmentally-friendly, non-CFC foam insulation
- Durable, enhanced-flow brass drain valve
- CSA certified and ASME rated temperature & pressure relief valve
- Multiple accessories available for customizable installation configurations

iCOMM™ SMART CONNECTIVITY

Download the free app to get started.



Apple logo and Apple App Store Logo are trademarks of Apple Inc. Google Play and the Google Play logo are trademarks of Google LLC.