



### ADAPT® NC NON-CONDENSING TANKLESS WITH X3® SCALE PREVENTION TECHNOLOGY

Introducing State's ADAPT® NC non-condensing gas tankless water heaters, delivering reliable, on-demand performance and the flexibility to install in practically any residential setting.

#### FEATURES:

#### X3® SCALE PREVENTION TECHNOLOGY (PATENTED DESIGN)

- Integrated into all X3 models;
- No annual descaling required with X3 models
- X3 models maintain like-new performance longer; extends life up to three times versus unprotected unit

#### PERFORMANCE & EFFICIENCY

- 180,000 and 199,000 BTU/h
- 10,000 BTU min. input
- Max Flow Rate 10.5 GPM; 0.4 GPM activation; 0.26 GPM for continuous fire
- 0.82 UEF
- Ultra Low NOx – Complies with SCAQMD Rule 1146.2\*

#### EASE OF INSTALLATION

- Indoor or Outdoor Models
- 3/4" Gas Line or larger
- Concentric (Direct Vent) - Indoor
- Pressure relief valve included with X3 models
- Outdoor rated power cord standard on every unit

- Cascade up to 12 units with single cable per heater, cable included
- Approved for installation in manufactured homes

#### WARRANTY

- No hardwater exclusions on X3 models; exclusions apply to Base (B) models
- 15-year limited warranty (X3 models), 10-year limited warranty (B models), on heat exchanger in residential applications
- 5-year limited warranty on all parts in residential applications
- 1-year limited warranty on heat exchanger and parts in commercial applications

\*Ultra Low NOx – Complies with SCAQMD Rule 1146.2 and other air quality management districts with similar NG NOx emission requirements of 14 ng/J or 20 ppm at 3% O<sub>2</sub>.



STI-180B,  
STI-199B



STO-180B,  
STO-199B



STI-180X3,  
STI-199X3  
with Integrated X3  
Scale Prevention  
Technology

STO-180X3,  
STO-199X3



CSA/ANSI Z21.10.3 • CSA 4.3

# SOLID. STATE.



# COMMERCIAL-GRADE

## RESIDENTIAL GAS WATER HEATERS

### ADAPT® NC NON-CONDENSING TANKLESS WITH X3® SCALE PREVENTION TECHNOLOGY - INDOOR

		STI-180B-N	STI-180X3-N	STI-199B-N	STI-199X3-N
Installation Type		Indoor			
X3® Scale Prevention Technology		Not Included	Integrated	Not Included	Integrated
Gas Consumption Input	Min. BTU/H	10,000			
	Max. BTU/H	180,000		199,000	
Fuel Type		Natural Gas			
Heat Exchanger		Copper			
Uniform Energy Factor (UEF)		0.82			
Maximum GPM**		10.0		10.5	
Activation GPM		0.4 GPM			
Continuous Fire GPM		0.26 GPM			
Water Pressure Min. - Max.		15 - 150 PSI (40 PSI Recommended for Maximum Flow)			
Supply Gas Pressure (NG)	Min. in W.C. (kPa)	4.0 (1.0)			
	Max. in W.C. (kPa)	10.5 (2.6)			
Hot/Cold Connections		3/4" NPT			
Gas Connection		3/4" NPT			
Temperature Settings Min. - Max.		100°F (38°C) - 140°F (60°C); Default 120°F (49°C)			
Ignition System		Electronic Ignition			
Power Supply		120V, 60Hz, <5A			
Sound Level		59.9 dB**		62.8 dB**	
Elevation		Certified from Sea Level to 7,800' (2,377.4 m)			
Freeze Protection*		- 5°F (-21°C)			
Venting - Exhaust, Intake	Type	Concentric (Direct Vent)			
	Size, Max Run	3" x 5", 45'			
	Material	CoxCentric®, Centrotherm Eco Systems Direct Vent APNC35, Ubbink, or Metal-Fab Corr/Guard®			
Dimensions - Unit	Height***	27.92" (70.9 cm)	36.88" (93.7 cm)	27.92" (70.9 cm)	36.88" (93.7 cm)
	Width	15.51" (39.4 cm)			
	Depth	10.63" (27 cm)			
	Weight	65 lb. (29.5 kg)			
Dimensions - Shipping****	Height	16.25" (41.3 cm)			
	Width	20.63" (52.4 cm)			
	Depth	34.25" (87 cm)			
	Weight	73 lb. (33.1 kg)			

\*\* Current numbers based on factory settings

\*\*\*Height with integrated X3 Scale Control Media cartridge installed.

\*\*\*\*Packaged and shipped on unit back.

\*Internal freeze protection for heater only; X3 cartridge requires anti-freeze kit sold separately

Included with Heater: Manual, Pressure Relief Valve (X3 models only), Wall Mounting Bracket and Hardware, Vent Port Screws, Cascading Cable, Bird Screens



# COMMERCIAL-GRADE

## RESIDENTIAL GAS WATER HEATERS

### ADAPT® NC NON-CONDENSING TANKLESS WITH X3® SCALE PREVENTION TECHNOLOGY - OUTDOOR

		STO-180B-N	STO-180X3-N	STO-199B-N	STO-199X3-N
Installation Type		Outdoor			
X3® Scale Prevention Technology		Not Included	Integrated	Not Included	Integrated
Gas Consumption Input	Min. BTU/H	10,000			
	Max. BTU/H	180,000		199,000	
Fuel Type		Natural Gas			
Heat Exchanger		Copper			
Uniform Energy Factor (UEF)		0.82			
Maximum GPM**		10.0		10.5	
Activation GPM		0.4 GPM			
Continuous Fire GPM		0.26 GPM			
Water Pressure Min. - Max.		15 - 150 PSI (40 PSI Recommended for Maximum Flow)			
Supply Gas Pressure (NG)	Min. in W.C. (kPa)	4.0 (1.0)			
	Max. in W.C. (kPa)	10.5 (2.6)			
Hot/Cold Connections		3/4" NPT			
Gas Connection		3/4" NPT			
Temperature Settings Min. - Max.		100°F (38°C) - 140°F (60°C); Default 120°F (49°C)			
Ignition System		Electronic Ignition			
Power Supply		120V, 60Hz, <5A			
Sound Level		54.4 dB**		56.1 dB**	
Elevation		Certified from Sea Level to 5,400' (1,645.9 m)			
Freeze Protection*		- 5°F (-21°C)			
Dimensions - Unit	Height***	25.40" (64.5 cm)	34.31" (87.2 cm)	25.40" (64.5 cm)	34.31" (87.2 cm)
	Width	15.51" (39.4 cm)			
	Depth	11.22" (28.5 cm)			
	Weight	65 lb. (29.5 kg)			
Dimensions - Shipping****	Height	16.25" (41.3 cm)			
	Width	20.63" (52.4 cm)			
	Depth	34.25" (87 cm)			
	Weight	73 lb. (33.1 kg)			

\*\* Current numbers based on factory settings

\*\*\*Height with integrated X3 Scale Control Media cartridge installed.

\*\*\*\*Packaged and shipped on unit back.

\*Internal freeze protection for heater only; X3 cartridge requires anti-freeze kit sold separately

Included with Heater: Manual, Pressure Relief Valve (X3 models only), Wall Mounting Bracket and Hardware, Vent Port Screws, Cascading Cable, Bird Screens

### ADAPT® NC NON-CONDENSING TANKLESS WITH X3® SCALE PREVENTION TECHNOLOGY DIMENSIONS

#### INDOOR

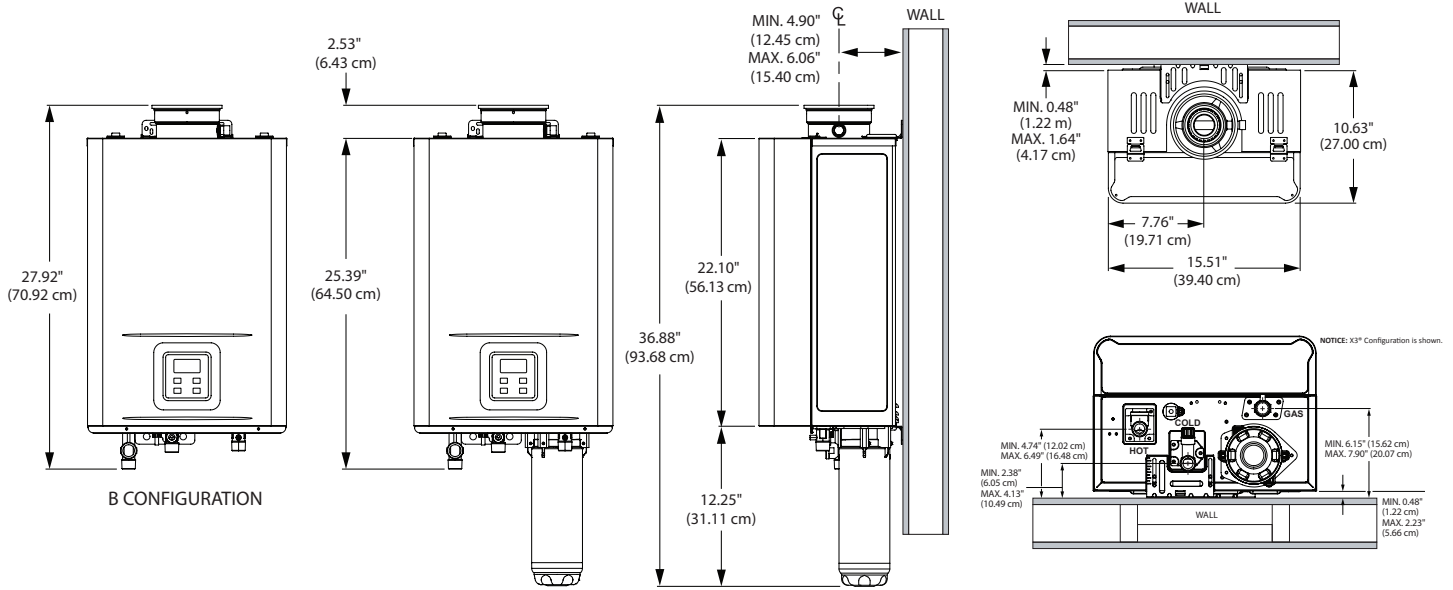

#### OUTDOOR

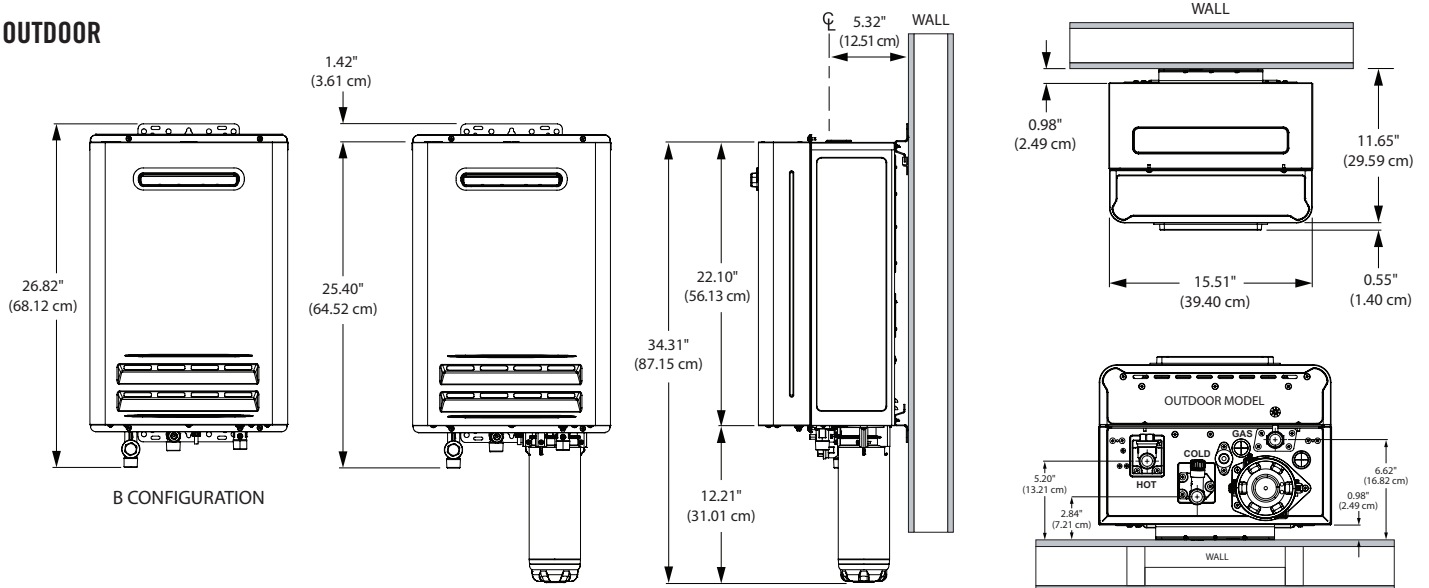

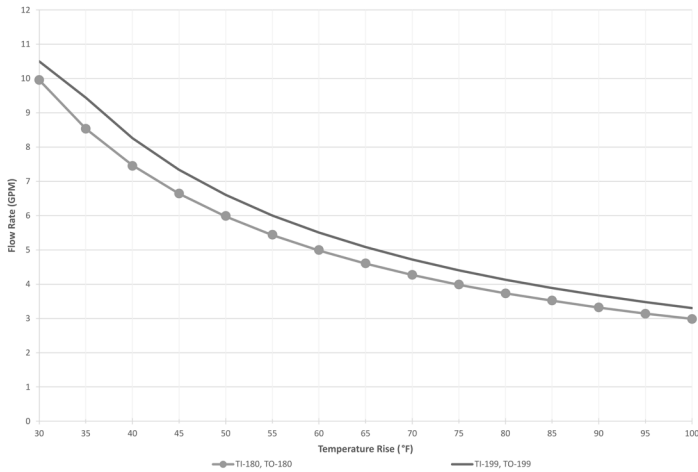

### TI, TO FLOW RATE CAPACITY

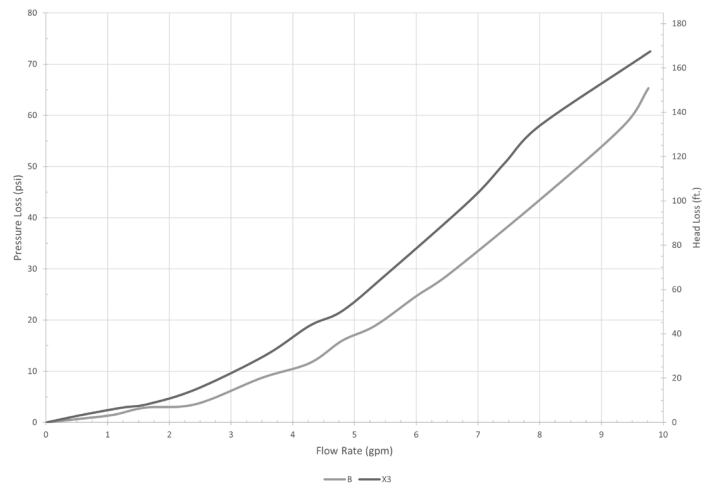

### PRESSURE LOSS

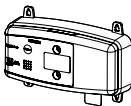
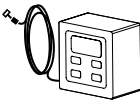

### ADAPT® NC NON-CONDENSING TANKLESS WITH X3® SCALE PREVENTION TECHNOLOGY

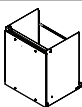
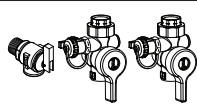
Item		Description
Wi-Fi Module Kit 100371922		Wi-Fi Module for electronically connecting tankless water heaters to the internet and adapter to connect to the water heater. <ul style="list-style-type: none"> <li>• Module (1x)</li> <li>• Cable (1x)</li> <li>• Adapter (1x)</li> </ul>
Remote Temperature Controller 100383909		Remote Temperature Controller with 10' (3 m) cable.
Communication Cable - 10' (3 m) 100377341		Replacement Communication Cable for Remote Temperature Controller or WIFI Module, or On-Demand Receiver, 10' (3 m).
Communication Cable - 32' (10 m) 100377342		Extended Communication Cable for Remote Temperature Controller or WIFI Module, or On-Demand Receiver, 32' (10 m).
X3 Freeze Protection (X3 Models) 100325654		X3 Cartridge Freeze Protection can add an extra layer of freeze protection to external SCM cartridge. Cartridge not protected by heater's internal freeze protection.
Pipe Cover 100387711		Pipe Cover protects plumbing connections to the heater while improving the appearance of the installation. Affixes to bottom of heater.
Isolation Valve Kit with Pressure Relief Valve 100112156		Isolation Valve supports routine maintenance and allows for draining and flushing the heater; whereas, the Pressure Relief Valve, as the name implies, serves to limit internal pressure in the system. Not necessary for X3 models. Check local codes for applicability.