

Instruction Manual

HIGH-EFFICIENCY COMMERCIAL GAS WATER HEATERS

MODELS FLEX 60G/100G/119G

SERIES 410

INSTALLATION - OPERATION - SERVICE - MAINTENANCE

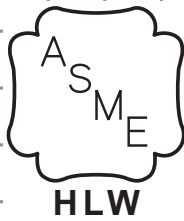

WATER QUALITY



WARNING: If the information in these instructions is not followed exactly, a fire or explosion may result causing property damage, personal injury or death.

- Do not store or use gasoline or other flammable vapors and liquids in the vicinity of this or any other appliance.
- **WHAT TO DO IF YOU SMELL GAS:**
 - Do not try to light any appliance.
 - Do not touch any electrical switch; do not use any phone in your building.
 - Immediately call your gas supplier from a neighbor's phone. Follow the gas supplier's instructions.
 - If you cannot reach your gas supplier, call the fire department.
- Installation and service must be performed by a qualified installer, service agency or the gas supplier.

Thank you for buying this energy efficient water heater. We appreciate your confidence in our products.



WARNING

Safety Hazard



Failure to follow these instructions and safety messages could result in death or serious injury.

Read and understand this instruction manual and the safety messages herein before installing or operating or servicing this water heater.

This manual must remain with the water heater.

For Your Safety

AN ODORANT IS ADDED TO THE GAS USED BY THIS WATER HEATER.

PLACE THESE INSTRUCTIONS ADJACENT TO HEATER AND NOTIFY OWNER TO KEEP FOR FUTURE REFERENCE.

KEEP THIS MANUAL IN THE POCKET ON HEATER FOR FUTURE REFERENCE WHENEVER MAINTENANCE ADJUSTMENT OR SERVICE IS REQUIRED.

CONTENTS

APPROVALS.....	3	AL29-4C® Vent Installations	40
GENERAL SAFETY INFORMATION.....	3	Common Venting.....	40
Do Not Operate If Damaged	3	Concentric Termination Installation	41
Limiting the Risk of Scalding	3	Low Profile Vent Installation	44
Grounding Instructions	3	Venting Arrangements.....	46
Hydrogen Gas Flammable	4	Termination Clearances Sidewall Power Vent.....	48
Important Definitions	4	Termination Clearances Sidewall Direct Vent	49
Hazard Messages	4	INSTALLING THE WATER HEATER.....	50
INTRODUCTION	8	Condensate Drain Installation	50
Abbreviations Used	8	Leak Detection Module Installation	50
Qualifications.....	8	Supply Gas Line Installation.....	51
ICOMM™	8	Gas Line Leak Testing.....	53
Building Management System	8	Electrical Wiring	53
Leak Detection	8	Water Line Connections	54
Automatic Water Shut-Off Valve.....	8	START UP	56
Preparing for the Installation	8	Prior to Start up	56
FEATURES AND COMPONENTS.....	10	Initial Start Up and AIQ™ Calibration	56
Basic Operation.....	10	Gas Type Calibration.....	57
Modulation.....	10	Start Up Conditions	58
Gas Valve.....	10	Operational Conditions.....	58
Blower/Burner Assembly Detail.....	10	Lighting the Water Heater	60
Top View Components	11	Checking the Firing Rate.....	61
Side View Components.....	14	High Altitude Installations	62
INSTALLATION CONSIDERATIONS	17	TEMPERATURE REGULATION.....	63
Rough In Dimensions.....	17	High Temperature Limit Control (ECO)	63
Locating the Water Heater	18	Thermostat Control	63
Optional Terminations	19	CONTROL SYSTEM OPERATION.....	65
Hard Water.....	19	Limiting the Risk of Scalding	65
Circulation Pumps	19	Wi-Fi.....	65
Insulation Blankets	19	Lockout Function	65
INSTALLATION REQUIREMENTS	21	Control System Overview.....	65
Gas Supply Systems.....	21	Control System Navigation.....	65
Supply Gas Regulator	21	User Settings & Control System Menus.....	67
Power Supply	21	MAINTENANCE	79
Mixing Valves	22	Maintenance Schedule.....	79
Dish-washing Machines	22	Draining and Flushing	79
Closed Water Systems.....	22	Sediment Removal.....	80
Thermal Expansion	22	Lime Scale Removal	80
Temperature-Pressure Relief Valve	22	Burner Flame Inspection	81
Condensate Drain	24	Anode Rod Maintenance.....	81
Combustible Material Storage.....	25	Drain Valve and Access Panels	81
Contaminated Air.....	25	Temperature-Pressure Relief Valve Test.....	82
Air Requirements	25	Vent System Maintenance	82
Fresh Air Openings For Confined Spaces.....	26	TROUBLESHOOTING	83
Massachusetts Installation Requirements	29	Installation Checklist	83
VENTING INSTALLATION	30	Sequence of Operation	83
General Venting Information	30	Sequence of Operation	84
Category IV Appliances.....	30	Operational Problems	85
Venting Requirements.....	32	Fault and Alert Conditions	86
Venting Installation Sequence.....	35	Fault and Alert Conditions	87
Power Vent Installation.....	35	Checking for Leaks	100
Direct Vent Installation	35	Checking the Threaded Fittings	100
Vertical Termination Installation.....	36	DIAGRAMS	101
Sidewall Termination Installation	38	Wiring Diagrams.....	101
Polypropylene Installations (Rigid).....	39	Water Piping Diagrams	105
Flexible Polypropylene.....	39		

APPROVALS

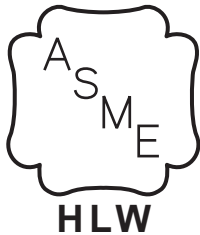

Note: ASME construction is optional on the 60G and 100G water heaters covered in this manual.

GENERAL SAFETY INFORMATION

DO NOT OPERATE IF DAMAGED

DO NOT USE THIS APPLIANCE IF ANY PART HAS BEEN EXPOSED TO FLOODING OR WATER DAMAGE. Immediately call a qualified service agency to inspect the appliance and to make a determination on what steps should be taken next.

If the unit is exposed to the following, do not operate heater until all corrective steps have been made by a qualified service agency.

1. External fire.
2. Damage.
3. Firing without water.

LIMITING THE RISK OF SCALDING

For a variety of reasons, water heaters can produce water that is much hotter than its temperature setting. Take precautions to prevent this higher temperature water from reaching the water fixtures.

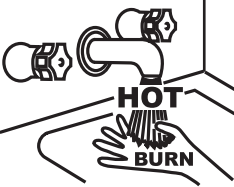
 WARNING	
Burn Hazard	
	<p>The temperature of the water in the water heater can exceed the thermostat setting and be hot enough to cause burns.</p> <p>To reduce the risk of unusually hot water reaching the fixtures in the house, install point of use thermostatic mixing valves at each point of use.</p>

According to a national standard, *Performance Requirements for Water Temperature Limiting Devices (ASSE 1070)* and many local plumbing codes, the water heater's gas control valve should not be used as the sole means to regulate water temperature and avoid scalds.

A properly adjusted thermostatic mixing valve at each point of use allows you to set the tank temperature to a higher setting without increasing risk of scalds. A higher temperature setting allows the tank to provide much more hot water and can help provide proper water temperatures for appliances such as dishwashers and washing machines.

GROUNDING INSTRUCTIONS

This water heater must be grounded in accordance with the *National Electrical Code* and/or local codes. These codes must be followed in all cases. Failure to ground this water heater properly may also cause erratic control system operation.

This water heater must be connected to a grounded metal, permanent wiring system; or an equipment grounding conductor must be run with the circuit conductors and connected to the equipment grounding terminal or lead on the water heater.

HYDROGEN GAS FLAMMABLE

Hydrogen gas can be produced in a hot water system served by this water heater that has not been used for a long period of time (generally two weeks or more). Hydrogen gas is extremely flammable. To reduce the risk of injury under these conditions, it is recommended that a hot water faucet served by this water heater be opened for several minutes before using any electrical appliance connected to the hot water system. If hydrogen is present there will probably be an unusual sound such as air escaping through the pipe as the water begins to flow. There should be no smoking or open flame near the faucet at the time it is open.

⚠ WARNING	
Explosion Hazard	
	<p>Flammable hydrogen gases can form in water pipes. The hydrogen can explode if it is exposed to flame and can cause severe injury or death.</p> <p>Keep all ignition sources away from faucet when turning on hot water.</p>

Verify the power to the water heater is turned off before performing any service procedures. The Enable /Disable switch on front panel disables the gas valve. Electrical supply must be turned off at circuit breaker serving water heater.

IMPORTANT DEFINITIONS

Qualified Installer: A qualified installer must have ability equivalent to a licensed tradesman in the fields of plumbing, air supply, venting and gas supply, including a thorough understanding of the requirements of the **National Fuel Gas Code, ANSI Z223.1/NFPA 54** as it relates to the installation of gas fired water heaters. The qualified installer must also be familiar with the design features and use of flammable vapor ignition resistant water heaters and have a thorough understanding of this Installation and Operating manual.

Service Agency: A service agency also must have ability equivalent to a licensed tradesman in the fields of plumbing, air supply, venting and gas supply, including a thorough understanding of the requirements of the **National Fuel Gas Code”, ANSI Z223.1/NFPA 54**

as it relates to the installation of gas fired water heaters. The service agency must also have a thorough understanding of this Installation and Operating manual, and be able to perform repairs strictly in accordance with the service guidelines provided by the manufacturer.

Gas Supplier: The Natural Gas or Propane Utility or service who supplies gas for utilization by the gas burning appliances within this application. The gas supplier typically has responsibility for the inspection and code approval of gas piping up to and including the Natural Gas meter or Propane storage tank of a building. Many gas suppliers also offer service and inspection of appliances within the building.

HAZARD MESSAGES

The proper installation, use, and servicing of this water heater is extremely important to your safety and the safety of others.

Many safety-related messages and instructions have been provided in this manual and on your own water heater to warn you and others of a potential injury hazard. Read and obey all safety messages and instructions throughout this manual. It is very important that the meaning of each safety message is understood by you and others who install, use, or service this water heater.

	<p>This is the safety alert symbol. It is used to alert you to potential personal injury hazards. Obey all safety messages that follow this symbol to avoid possible injury or death. Keep this manual near the water heater.</p>
---	---

⚠ DANGER	DANGER indicates an imminently hazardous situation which, if not avoided, will result in injury or death.
⚠ WARNING	WARNING indicates a potentially hazardous situation which if not avoided, could result in injury or death.
⚠ CAUTION	CAUTION indicates a potentially hazardous situation which, if not avoided, could result in minor or moderate injury.
CAUTION	CAUTION used without the safety alert symbol indicates a potentially hazardous situation which, if not avoided, could result in property damage.

All safety messages will generally tell you about the type of hazard, what can happen if you do not follow the safety message, and how to avoid the risk of injury.

⚠ WARNING
Safety Hazard



Failure to follow these instructions and safety messages could result in death or serious injury.

Read and understand this instruction manual and the safety messages herein before installing or operating or servicing this water heater.

This manual must remain with the water heater.

⚠ WARNING
Burn Hazard

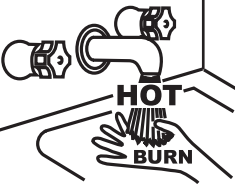

The temperature of the water in the water heater can exceed the thermostat setting and be hot enough to cause burns.

To reduce the risk of unusually hot water reaching the fixtures in the house, install point of use thermostatic mixing valves at each point of use.

⚠ WARNING
Explosion Hazard



Flammable hydrogen gases can form in water pipes. The hydrogen can explode if it is exposed to flame and can cause severe injury or death.

Keep all ignition sources away from faucet when turning on hot water.

CAUTION
Property Damage Hazard

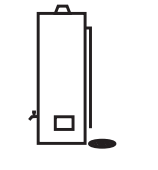

Over time, the tank and fittings of the water heater can begin to leak and cause water damage.

- Locate the water heater near an adequate drain and in an area where water leakage from the heater or connections will not result in damage to the area or the lower floors of the structure.
- Install the water heater in a drain pan.

⚠ WARNING
Fire or Explosion Hazard



- Do not store or use gasoline or other flammable vapors and liquids in the vicinity of this or any other appliance.
- Avoid all ignition sources if you smell gas.
- Do not expose water heater controls to excessive gas pressure.
- Use only the gas shown on the water heater rating label.
- Maintain required clearances to combustibles.
- Keep ignition sources away from faucets after extended periods of non-use.

Read instruction manual before installing, using or servicing water heater.

⚠ WARNING
Breathing Hazard - Carbon Monoxide Gas



- Do not obstruct water heater air intake with insulating blanket.
- Gas and carbon monoxide detectors are available.
- Install water heater in accordance with the instruction manual.

Breathing carbon monoxide can cause brain damage or death. Always read and understand instruction manual.

⚠ DANGER
Burn Hazard

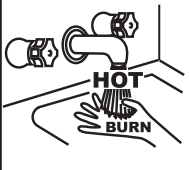

Because of the increased risk from scalding, if you set the water heater's gas control knob higher than 120°F (49°C), install thermostatic point-of-use mixing valves at each point of use. Due to the increased risk of scalding, do not set the temperature of the thermostatic mixing valves above 120°F (49°C).

⚠ WARNING
Explosion Hazard

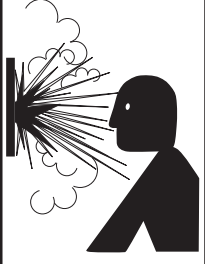

Normal operation of the water heater can cause it to become sufficiently over-heated and/or over-pressurized that it can explode, resulting in property damage, sever injury, or death.

To avoid this hazard, you must install a properly-sized temperature-pressure relief valve in opening provided.

- The temperature-pressure relief valve must comply with ANSI Z21.22-CSA 4.4 and ASME code.
- Do not plug, block, or cap the discharge line.

⚠ CAUTION
Property Damage Hazard



While the water heater is in routine operation, it can release hot water from the temperature-pressure relief valve discharge pipe in quantities that could cause damage to the surroundings.

Locate the water heater near an adequate drain and in an area where water from the temperature-pressure relief valve discharge pipe will not result in damage to the area or the lower floors of the structure.

⚠ DANGER	
Burn Hazard	
	<p>The discharge water from the temperature-pressure relief valve is hot enough to cause burns.</p> <p>Keep clear of the temperature-pressure relief valve discharge outlet.</p>

⚠ WARNING	
Breathing Hazard - Carbon Monoxide Gas	
	<ul style="list-style-type: none"> • Install water heater in accordance with the Instruction Manual and NFPA 54 or CAN/CSA-B149.1. • To avoid injury, combustion and ventilation air must be taken from outdoors. • Do not place chemical vapor emitting products near water heater.
<p>Breathing carbon monoxide can cause brain damage or death. Always read and understand instruction manual.</p>	

⚠ WARNING	
Fire and Explosion Hazard	
	<ul style="list-style-type: none"> • Do not use water heater with any gas other than the gas shown on the rating label. • Excessive gas pressure to gas valve can cause serious injury or death. • Turn off gas lines during installation. • Contact a qualified installer or service agency for installation and service.

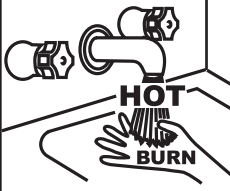
⚠ WARNING	
Burn Hazard	
	<p>The temperature of the water in the water heater can exceed the thermostat setting and be hot enough to cause burns.</p> <p>If you choose a higher temperature setting, install thermostatic mixing valves at each point-of-use to help avoid scalding.</p>

⚠ WARNING	
Breathing Hazard - Carbon Monoxide Gas	
	<ul style="list-style-type: none"> • Install vent system in accordance with codes. • Do not operate water heater if any part has been exposed to flooding or water damage. • High altitude models should be installed at elevations above 5,300 feet (1,615 m). For operation above 10,100 feet (3,079 m), a high altitude orifice must be installed. • Do not operate if soot buildup is present. • Do not obstruct water heater air intake with insulating jacket. • Do not place chemical vapor emitting products near water heater. • Gas and carbon monoxide detectors are available. • No vent damper installation is compatible with this power vented water heater. • Do NOT elevate any portion of the field supplied drain line beyond the 1/2" adapter above the adapter. This must be true for the entire length of the drain line including the exit into an appropriate drain. • Condensate lines must be free and clear of debris and must not allow back flow through the hose. The condensate lines must be able to flow freely to an appropriate drain. • Do not allow condensate lines to become crimped closed. • Analyze the entire vent system to make sure that condensate will not become trapped in a section of vent pipe and therefore reduce the open cross sectional area of the vent.
<p>Breathing carbon monoxide can cause brain damage or death. Always read and understand instruction manual.</p>	

⚠ WARNING	
Fire and Explosion Hazard	
	<p>Gas piping can leak gas from fittings and connections if it is not sealed properly. Gas leaks can cause fires and explosions resulting in severe injury or death.</p> <ul style="list-style-type: none"> • Use joint compound or thread sealer tape compatible with the type of gas you are using. • Leak test all gas connections before placing the water heater in operation. • Disconnect gas piping at main gas shutoff valve before leak testing. • Install sediment trap in accordance with NFPA 54 or CAN/CSA B149.1.

CAUTION	
Property Damage Hazard	
	<p>Avoid water heater damage from pressure fluctuations in closed water systems.</p> <ul style="list-style-type: none"> • Fill tank with water before operating. • Install thermal expansion tank if necessary. • Do not apply heat to cold water inlet. • Contact qualified installer or service agency.

⚠ WARNING	
Fire and Explosion Hazard	
	<p>Modifying the water heater to exceed the firing rate on the rating label can result in property damage, personal injury or death.</p> <ul style="list-style-type: none"> • Under no circumstances should the input exceed the rate shown on the water heater's rating label. • Over-firing could result in fire or explosion. • Gas and carbon monoxide detectors are available.

⚠ WARNING	
Breathing Hazard - Carbon Monoxide Gas	
	<ul style="list-style-type: none"> • Under no circumstances should the input exceed the rate shown on the water heater's rating label. • Overfiring could result in damage to the water heater and sooting. • Gas and carbon monoxide detectors are available.
<p>Breathing carbon monoxide can cause brain damage or death. Always read and understand instruction manual.</p>	

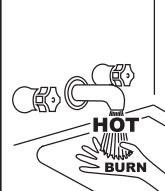
⚠ CAUTION	
Burn Hazard	
	<ul style="list-style-type: none"> • The combustion chamber and burner sleeve and housing become very hot during operation. • Do not reach into the burner housing or combustion chamber if the water heater is still hot. • Allow the water heater to cool and always use gloves when handling the main burner.

⚠ WARNING	
Electrical Shock Hazard	
	<p>Servicing this water heater exposes you to electrified components that can cause severe injury or death if you touch them.</p> <ul style="list-style-type: none"> • Turn off power at the branch circuit breaker serving the water heater before performing any service. • Label all wires prior to disconnecting when performing service. Wiring errors can cause improper and dangerous operation. • Verify proper operation after servicing.

⚠ WARNING	
Safety Hazard	
	<p>Jumping out control circuits or components can result in property damage, personal injury or death.</p> <ul style="list-style-type: none"> • Service should only be performed by a qualified service technician using proper test equipment. • Altering the water heater controls and/or wiring in any way could result in permanent damage to the controls or water heater and is not covered under the limited warranty. • Any bypass or alteration of the water heater controls and/or wiring will result in voiding the appliance warranty.

⚠ CAUTION	
Safety Hazard	
<p>Do not operate the water heater if it has been exposed to or exhibits the following:</p> <ul style="list-style-type: none"> • Exposed to flooding or water damage • External damage. • Firing without water. • Sooting. <p>Do not operate the water heater until all corrective steps have been made by a qualified service technician.</p>	

⚠ WARNING	
Explosion Hazard	
	<ul style="list-style-type: none"> • Overheated water can cause water tank explosion. • A properly sized temperature and pressure relief valve must be installed in the opening provided.

⚠ DANGER	
Burn Hazard	
	<p>The discharge water from the drain valve is hot enough to cause burns.</p> <p>Keep your hands clear of the drain valve discharge outlet.</p>

INTRODUCTION

Thank You for purchasing this water heater. Properly installed and maintained, it should give you years of trouble free service.

ABBREVIATIONS USED

Abbreviations found in this Instruction Manual include:

- ANSI - American National Standards Institute
- ASME - American Society of Mechanical Engineers
- AHRI - Air Conditioning, Heating and Refrigeration Institute
- NEC - National Electrical Code
- NFPA - National Fire Protection Association
- UL - Underwriters Laboratory
- CSA - Canadian Standards Association

QUALIFICATIONS

Qualified Installer or Service Agency

Installation and service of this water heater requires ability equivalent to that of a Qualified Agency (as defined by ANSI below) in the field involved. Installation skills such as plumbing, air supply, venting, gas supply and electrical supply are required in addition to electrical testing skills when performing service.

ANSI Z223.1 2006 Sec. 3.3.83:“Qualified Agency” - “Any individual, firm, corporation or company that either in person or through a representative is engaged in and is responsible for (a) the installation, testing or replacement of gas piping or (b) the connection, installation, testing, repair or servicing of appliances and equipment; that is experienced in such work; that is familiar with all precautions required; and that has complied with all the requirements of the authority having jurisdiction.”

If you are not qualified (as defined by ANSI above) and licensed or certified as required by the authority having jurisdiction to perform a given task do not attempt to perform any of the procedures described in this manual. If you do not understand the instructions given in this manual do not attempt to perform any procedures outlined in this manual.

iCOMM™

This water heater comes equipped with the iCOMM™ remote monitoring system. It allows users to monitor critical operations and diagnose issues remotely using the manufacturer’s water heater app (available for IOS and Android).

The iCOMM™ system can automatically notify selected personnel via email and or cellular phone text messages if operational problems or user defined Alert conditions should occur. The system is expandable to meet the needs of multiple heaters and groups of heaters.

To order or to find out more about ICC devices, Technical Support.

To connect your water heater to iCOMM, download the A. O. Smith app from the Apple App Store or Google Play store and follow the instructions for how to add your water heater.

BUILDING MANAGEMENT SYSTEM

This water heater is connectible to BACnet or Modbus compliant Supervisory controls via the optional BMS Gateway. This allows connection of the water heater to local Building Management Systems using Serial RS-485 (MS/TP) or IP connections.

LEAK DETECTION

The water heaters covered in this manual are equipped with a leak detection device that continuously tests for the presence of water in the immediate location of the water heater. If water is detected, it generates an alarm.

AUTOMATIC WATER SHUT-OFF VALVE

The optional Automatic Water Shut off Valve and Valve Control Board work in conjunction with the TRC to help reduce the risk of further water damage if a leak is detected by the leak detection device.

PREPARING FOR THE INSTALLATION

1. Read the entire manual before attempting to install or operate the water heater. Pay close attention to the **General Safety Information** (page 3). If you don’t follow the safety rules, the water heater may not operate safely. It could cause property damage, injury and/or death.

This manual contains instructions for the installation, operation, and maintenance of the water heater. It also contains warnings throughout the manual that you must read and be aware of. All warnings and all instructions are essential to the proper operation of the water heater and your safety.

Detailed installation diagrams are also found in this manual. These diagrams will serve to provide the installer with a reference. It is essential that all venting, water piping, gas piping and wiring be installed as shown.

Particular attention should be given to the installation of thermometers at the locations indicated in the piping diagrams as these are necessary for checking the operation of the water heater.

The principal components of the water heater are identified in **Features and Components** (page 10) in this manual. Use this reference to locate and identify various components on the water heater.

See **Installation Checklist** (page 83) and **Troubleshooting** (page 83). By using this checklist the user may be able to make minor operational adjustments and avoid unnecessary service calls. However, service and diagnostic procedures should only be performed by a Qualified Service Agency.

Note: Costs to correct installation errors are not covered under the limited warranty.

2. Be sure to turn off power when working on or near the electrical system of the water heater. Never touch electrical components with wet hands or when standing in water.

3. The installation must conform to all instructions contained in this manual and the local code authority having jurisdiction. These shall be carefully followed in all cases. Authorities having jurisdiction should be consulted before installation begins if there are any questions regarding compliance with local, state or national codes.

In the absence of local codes, the installation must comply with the current editions of the *National Fuel Gas Code, ANSI Z223.1/NFPA 54* and the *National Electrical Code, NFPA 70* or *CAN/CSA-B149.1*, the *Natural Gas and Propane Installation Code* and *CSA C22.1, the Canadian Electrical Code*. All documents are available from the Canadian Standards Association, 8501 East Pleasant Valley Road, Cleveland, OH 44131. NFPA documents are also available from the National Fire Protection Association, 1 Batterymarch Park, Quincy, MA 02269.

4. If after reading this manual you have any questions or do not understand any portion of the instructions, call the toll free number on the back cover of this manual for technical assistance. In order to expedite your request, please have the full Model, Serial and Series number of the water heater you are working with available for the technician. This information is located on the water heater's rating label.
5. Carefully plan the placement of the water heater. Examine the location to ensure that it complies with the requirements in *Rough In Dimensions* (page 17) and *Locating the Water Heater* (page 18).
6. For installation in California this water heater must be braced or anchored to avoid falling or moving during an earthquake. See instructions for correct installation procedures. Instructions may be obtained from California Office of the State Architect, 1102 Q Street, Suite 5100, Sacramento, CA 95811.
7. Massachusetts Code requires this water heater to be installed in accordance with *Massachusetts 248-CMR 2.00: State Plumbing Code* and *248-CMR 5*. See *Massachusetts Installation Requirements* (page 29).

FEATURES AND COMPONENTS

BASIC OPERATION

The water heaters covered in this manual have a helical coil shaped heat exchanger that is submerged in the storage tank. The water heater's Main Burner is a radial design burner, it is mounted on the top and fires downward through the heat exchanger. This is a forced draft burner; hot burning gases are forced through the heat exchanger under pressure and exit through the exhaust/vent connection located at the bottom of the water heater. See *Figure 1* and *Figure 2*.

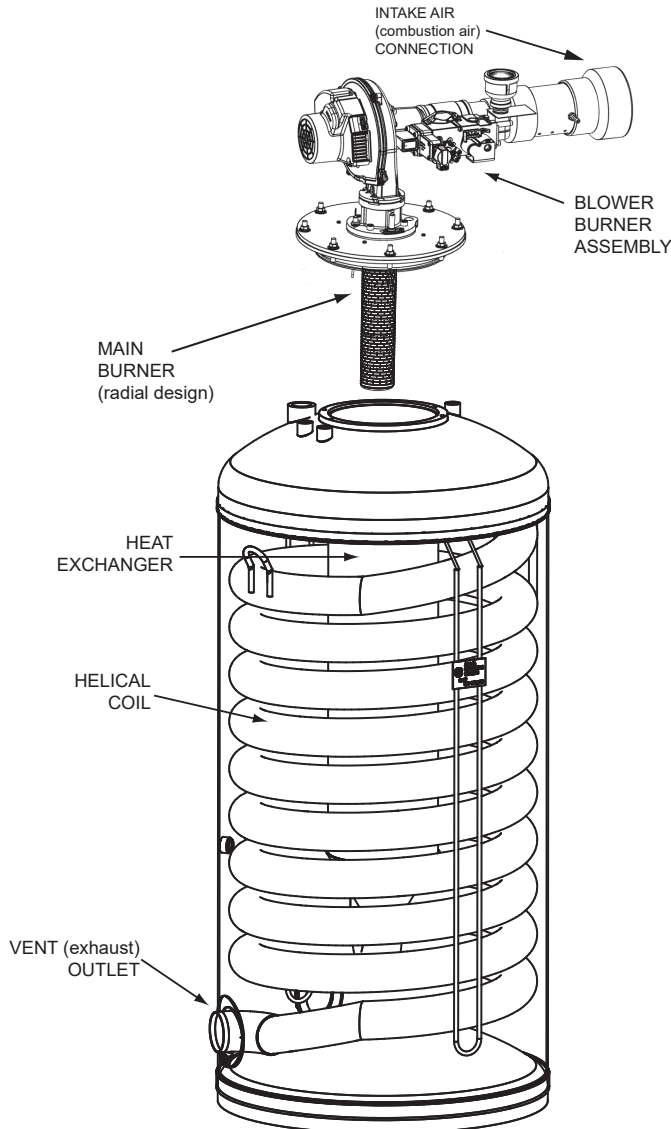

Figure 1. Operational Components

MODULATION

The water heaters covered by this manual are capable of adjusting their firing rate. The combustion blower is controlled by the CSC. The TRC and CSC monitor the water temperature in the tank and regulate the firing rate to achieve the target temperature set-point. The firing rate is dictated by the hot water draw, proximity to the tank temperature set-point, and various other temperature limitations.

GAS VALVE

This heater is equipped with a gas adaptive system and motor driven throttle. It is controlled by the CSC in conjunction with the TRC.

BLOWER/BURNER ASSEMBLY DETAIL

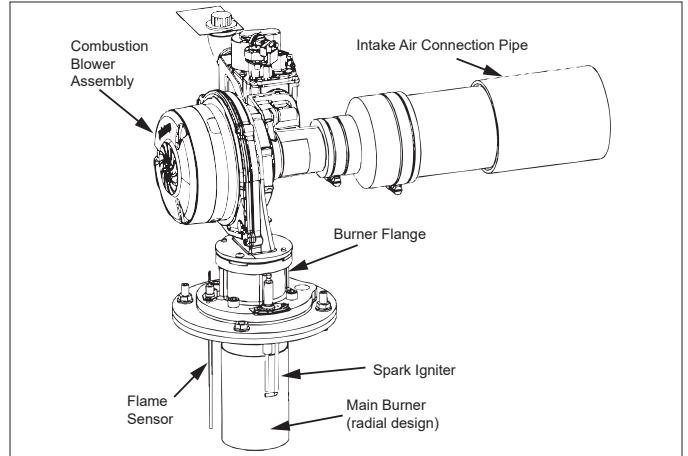

Figure 2. Blower/Burner Assembly - 60 Gallon

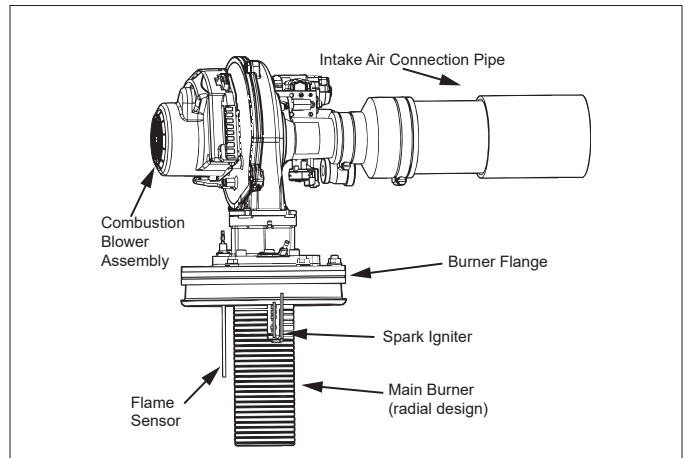

Figure 3. Blower/Burner Assembly - 100 Gallon

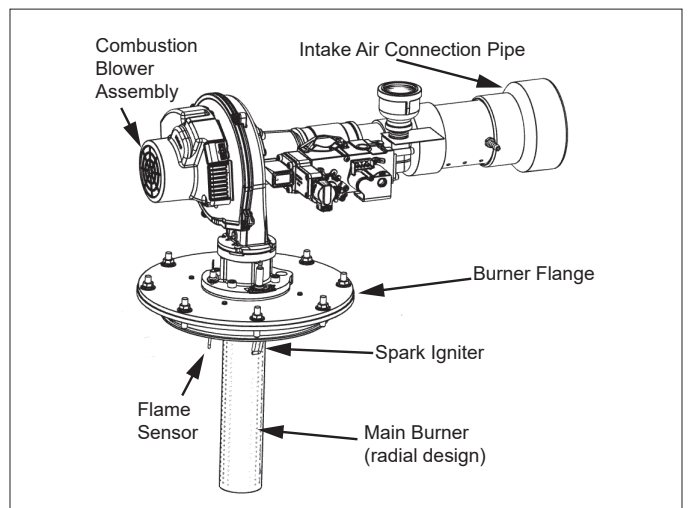

Figure 4. Blower-Burner Assembly - 119 Gallon

Spark Igniter

The control system energizes the spark ignition control with 120 VAC during the ignition period. The spark ignition control then sends a high-voltage electrical current to the spark igniter which in turn ignites the main burner air/gas mixture.

TOP VIEW COMPONENTS

60 Gallon Top View

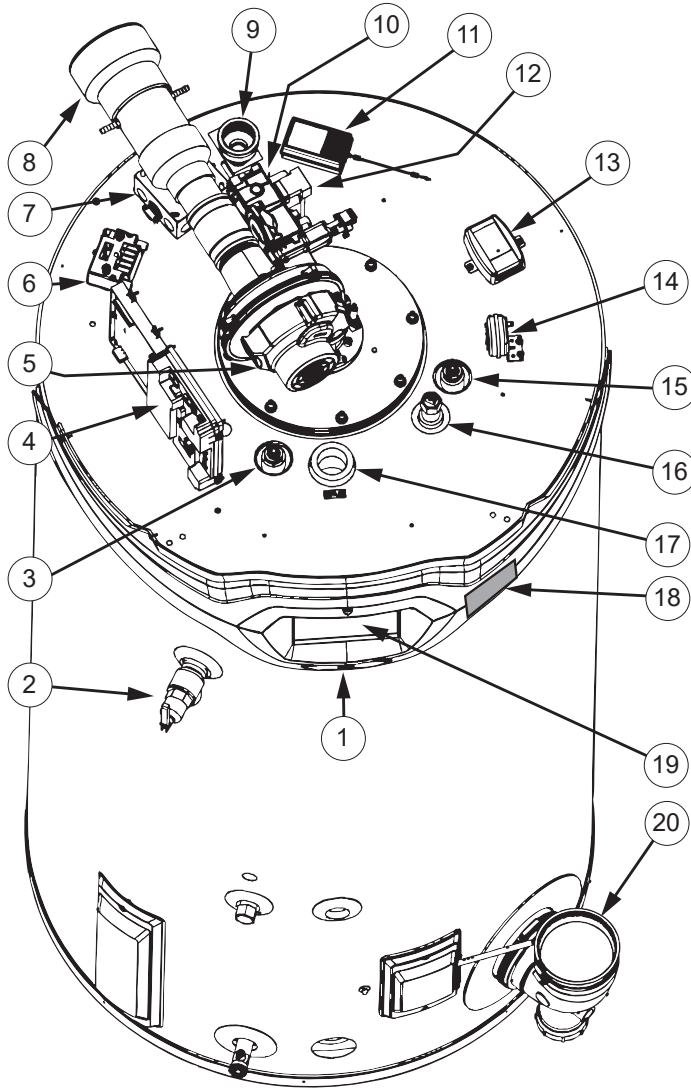

Figure 5. Top View, 60 Gallon

Flame Sensor

The control system also monitors the flame sensor to confirm a flame is present at the Main Burner. If a flame is not verified during the ignition trial period the control system will immediately deenergize the Gas Valve. See *Sequence of Operation* (page 84).

The Enable/Disable switch listed in this manual is NOT an “on/off” switch and does not disconnect 120 volt power to the control boards and other heater components.

1. **Enable/Disable Switch.** When in the “Disabled” position the switch removes electrical power from the gas valve so that water heating is disabled. The UIM, TRC, CSC, and other electrical components will still be energized and the display will read “Water Heating Disabled.”
2. **Temperature-Pressure Relief Valve (T & P Valve).** See *Temperature-Pressure Relief Valve* (page 22).
3. **Control boards (TRC and CSC) enclosure.** This enclosure houses the control system’s TRC and CSC. The temperature regulation control (TRC) and combustion and safety control (CSC) regulate water temperature and control all water heater functions. See *Control System Operation* (page 65).
4. **Combustion Blower Assembly.** Includes Gas Valve and Venturi gas feed system.
5. **Spark Ignition Transformer.** When energized, sends the electrical current to the spark igniter.
6. **120 VAC junction box.** Incoming power supply, ground connections, and other field-installed electrical connections are made here. See *Power Supply* (page 21) and *Power Supply Connections* (page 53).
7. Supply gas line connection. See the requirements for the supply gas line in *Table 4* (page 18) and *Table 5* (page 18).
8. **Water heater’s Gas Valve.**
9. **Intake air connection - PVC.** Refer to *Venting Installation* (page 30).
10. **Blocked Intake Air switch.** Normally closed contacts that open on fall in pressure. This switch is used to ensure intake (combustion) air to the water heater is not restricted. The control system monitors this switch and will disable heating operation if its contacts are open during a heating cycle.
11. **Powered anode rod 31.5”.** The water heaters covered in this manual are equipped with a powered (non sacrificial) anode rod. Protective current is fed by the control system to the titanium electrodes at the end of each anode rod. This current flows through the water to the conductive surfaces inside the storage tank which diminishes the corrosive effect of water when it in contact with a steel tank which diminishes the corrosive effect of water when it comes in contact with steel.
12. **Main Temperature Probe.** The water heater’s control system monitors this probe to detect water temperature in the upper portion of the storage tank.
13. Water outlet connection 1 1/2” NPT.
14. **Flex Memory Module (FMM) under cover:** The FMM board is located inside the plastic display enclosure. The FMM board enables an FMM device to communicate information with the heater. **DO NOT REMOVE OR DAMAGE THE FMM BOARD.**
15. **User Interface Module (UIM).** The UIM includes the display circuit board and the control system’s LCD Touch Display. Used to adjust various user settings and view operational information. See *Control System Operation* (page 65).
16. **Vent connection (exhaust/condensate elbow) - aluminum.** Refer to *Venting Installation* (page 30).

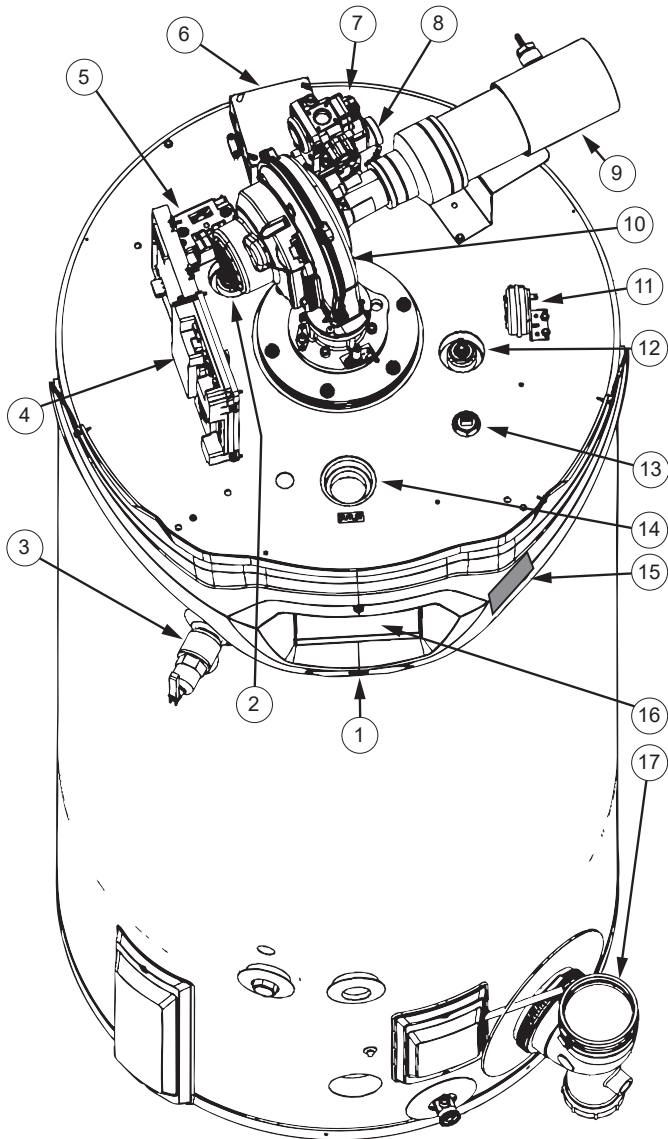

Figure 6. Top View, 100 Gallon

The Enable/Disable switch listed in this manual is NOT an “on/off” switch and does not disconnect 120 volt power to the control boards and other heater components.

1. **Water Heater’s Dual Voltage Enable/Disable Switch.** When in the “Disabled” position the switch removes electrical power from the gas valve so that water heating is disabled. The UIM, TRC, CSC, and other electrical components will still be energized and the display will read “Water Heating Disabled.”
2. **Powered anode 13.78”.** The water heaters covered in this manual are equipped with powered (non sacrificial) anode rods. Protective current is fed by the control system to the titanium electrodes at the end of each anode rod. This current flows through the water to the conductive surfaces inside the storage tank which diminishes the corrosive effect of water when it comes in contact with steel.
3. **Temperature-Pressure Relief Valve (T & P Valve).** See *Temperature-Pressure Relief Valve* (page 22).
4. **Control boards (TRC and CSC) enclosure.** This enclosure houses the control system’s TRC and CSC. The temperature regulation control (TRC) and combustion and safety control (CSC) regulate water temperature and control all water heater functions. See *Control System Operation* (page 65).
5. **Spark Ignition Transformer.** When energized, sends the electrical current to the spark igniter.
6. **120 VAC junction box.** Incoming power supply, ground connections, and other field-installed electrical connections are made here. See *Power Supply* (page 21) and *Power Supply Connections* (page 53).
7. **Supply gas line connection.** See the requirements for the supply gas line in *Table 4* (page 18) and *Table 5* (page 18).
8. **Water heater’s Gas Valve.**
9. **Intake air connection - PVC.** Refer to *Venting Installation* (page 30).
10. **Combustion Blower Assembly.** Includes Gas Valve and Venturi gas feed system.
11. **Blocked Intake Air switch.** Normally closed contacts that open on fall in pressure. This switch is used to ensure intake (combustion) air to the water heater is not restricted. The control system monitors this switch and will disable heating operation if its contacts are open during a heating cycle.
12. **Powered anode 48”.**
13. **Main Temperature Probe.** The water heater’s control system monitors this probe to detect water temperature in the upper portion of the storage tank.
14. **Water outlet connection 1 1/2” NPT.**
15. **Flex Memory Module (FMM) under cover:** The FMM board is located inside the plastic display enclosure. The FMM board enables an FMM device to communicate information with the heater. **DO NOT REMOVE OR DAMAGE THE FMM BOARD.**
16. **User Interface Module (UIM).** The UIM includes the display circuit board and the control system’s LCD Touch Display. Used to adjust various user settings and view operational information. See *Control System Operation* (page 65).
17. **Vent connection (exhaust/condensate elbow) - aluminum.** Refer to *Venting Installation* (page 30).

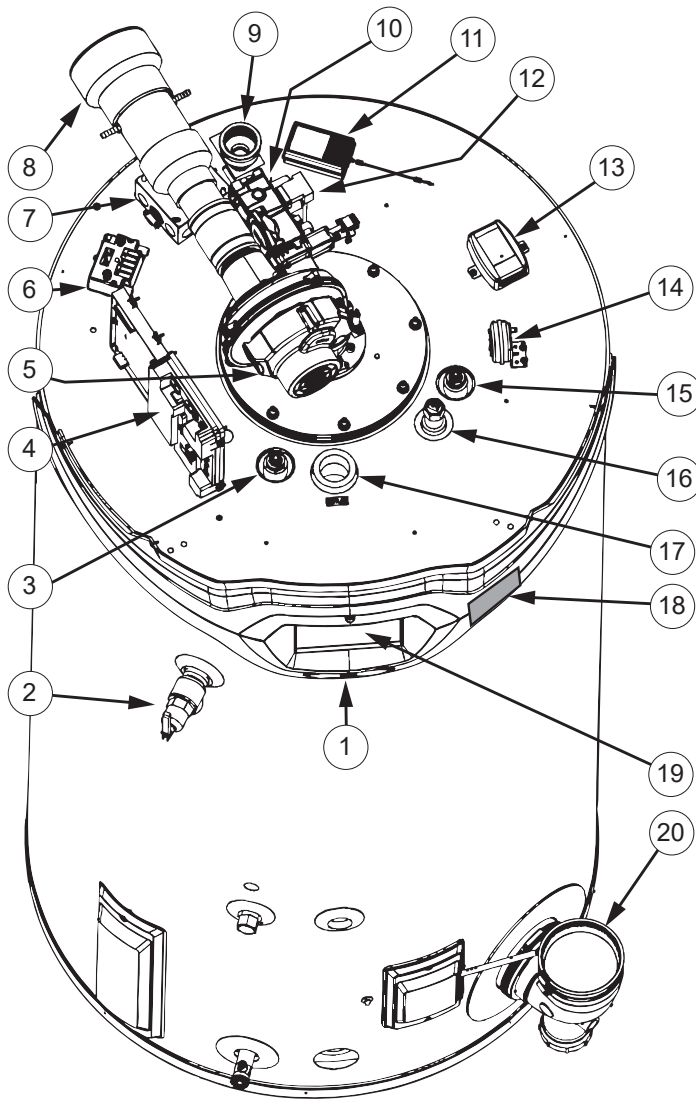

Figure 7. Top View, 119 Gallon

The Enable/Disable switch listed in this manual is NOT an “on/off” switch and does not disconnect 120 volt power to the control boards and other heater components.

1. **Water Heater’s Dual Voltage Enable/Disable Switch.** When in the “Disabled” position the switch removes electrical power from the gas valve so that water heating is disabled. The UIM, TRC, CSC, and other electrical components will still be energized and the display will read “Water Heating Disabled.”
2. **Temperature-Pressure Relief Valve (T & P Valve).** See *Temperature-Pressure Relief Valve* (page 22).
3. **Powered anode rod 19.69”.** The water heaters covered in this manual are equipped with powered (non sacrificial) anode rods. Protective current is fed by the control system to the titanium electrodes at the end of each anode rod. This current flows through the water to the conductive surfaces inside the storage tank which diminishes the corrosive effect of water when it comes in contact with steel.
4. **Control boards (TRC and CSC) enclosure.** This enclosure houses the control system’s TRC and CSC. The temperature regulation control (TRC) and combustion and safety control (CSC) regulate water temperature and control all water heater functions. See *Control System Operation* (page 65).
5. **Combustion Blower Assembly.** Includes Gas Valve and Venturi gas feed system.
6. **Spark Ignition Transformer.** When energized, sends the electrical current to the spark igniter.
7. **120 VAC junction box.** Incoming power supply, ground connections, and other field-installed electrical connections are made here. See *Power Supply* (page 21) and *Power Supply Connections* (page 53).
8. **Intake air connection - PVC.** Refer to *Venting Installation* (page 30).
9. **Supply gas line connection.** See the requirements for the supply gas line in *Table 4* (page 18) and *Table 5* (page 18).
10. **Powered anode, shielded, 118 dia. x 31.5.** Approximate location (not visible),
11. **CPAM Power Supply:** Provides power to the CPAM.
12. **Water heater’s Gas Valve.**
13. **CPAM (Powered Anode Module):** Axillary control for the operation of powered anodes.
14. **Blocked Intake Air switch.** Normally closed contacts that open on fall in pressure. This switch is used to ensure intake (combustion) air to the water heater is not restricted. The control system monitors this switch and will disable heating operation if its contacts are open during a heating cycle.
15. **Powered anode 48”.**
16. **Main Temperature Probe, 1 of 2 temperature probes.** The water heater’s control system monitors this probe to detect water temperature in the upper portion of the storage tank.
17. **Water outlet connection 1 1/2” NPT.**
18. **Flex Memory Module (FMM) under cover:** The FMM board is located inside the plastic display enclosure. The FMM board enables an FMM device to communicate information with the heater. **DO NOT REMOVE OR DAMAGE THE FMM BOARD.**
19. **User Interface Module (UIM).** The UIM includes the display circuit board and the control system’s LCD Touch Display. Used to adjust various user settings and view operational information. See *Control System Operation* (page 65).
20. **Vent connection (exhaust/condensate elbow) - aluminum.** Refer to *Venting Installation* (page 30).

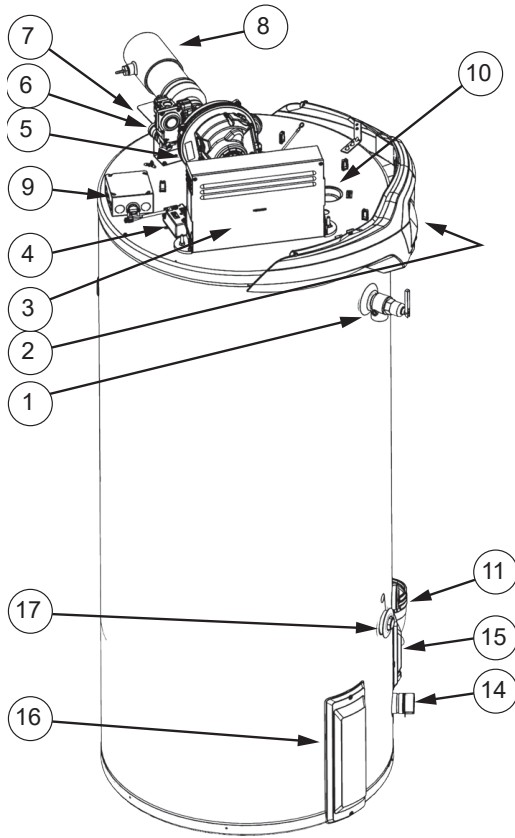

Figure 8. Left-Side Components

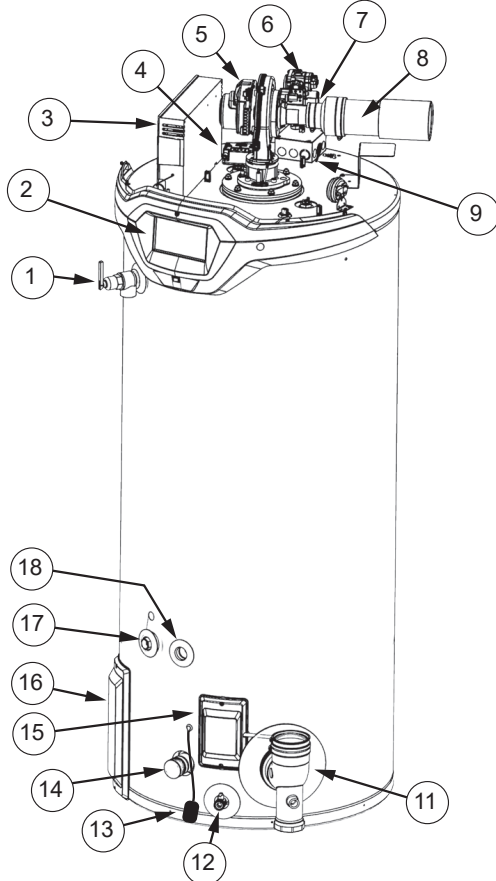

Figure 9. Right-Side Components

60 and 100 Gallon Models

1. **Temperature-Pressure Relief Valve.** See *Temperature-Pressure Relief Valve* (page 22).
2. **User Interface Module (UIM).** The UIM includes the display circuit board and the control system's LCD Touch Display. Used to adjust various user settings and view operational information. See *Control System Operation* (page 65).
3. **Control boards enclosure.** See *Figure 5*, *Figure 6*, and *Figure 7* (page 12) for description.
4. **Spark Ignition Transformer.** When energized, sends the electrical current to the spark igniter.
5. **Combustion Blower.**
6. **Water heater Gas Valve.**
7. **Supply gas line connection.** See the requirements for the supply gas line in *Table 4* (page 18) and *Table 5* (page 18).
8. **Intake air connection - PVC.**
9. **120 VAC junction box.** Incoming power supply, ground connections, and other field installed electrical connections are made here. See *Power Supply* (page 21) and *Power Supply Connections* (page 53).
10. **Water outlet - 1 1/2" NPT connection.**
11. **Vent connection (exhaust/condensate elbow) - Aluminum.**
12. **Water heater drain valve.**
13. **Leak Detection Module.** This feature senses the buildup of water in the vicinity of the appliance. (Must be plugged in to operate the unit).
14. **Water inlet connection - 1 1/2" NPT connection.**
15. **Blocked Exhaust (vent) switch.** Normally closed contacts that open on a rise in pressure. This switch is used to ensure that the Exhaust (vent) piping connected to the water heater is not restricted. The control system monitors this switch and will disable heating operation if its contacts are open during a heating cycle.
16. **Clean-out access panel.** Covers water heater clean-out opening and ASME plate where applicable.
17. **Lower Temperature Probe, 1 of 2 temperature probes.** The water heater's control system monitors this probe to detect water temperature in the lower portion of the storage tank.
18. **Recirculation loop return connection - 3/4" NPT.**
19. **Optional BMS Module.** This feature enables the heater to communicate with a building management system. *Not shown/visible.

119 Gallon Models

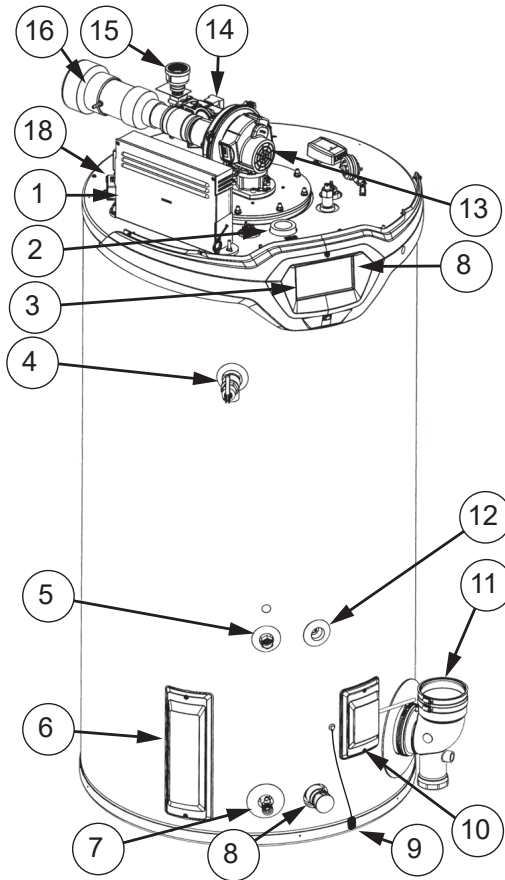

Figure 10. Left Side

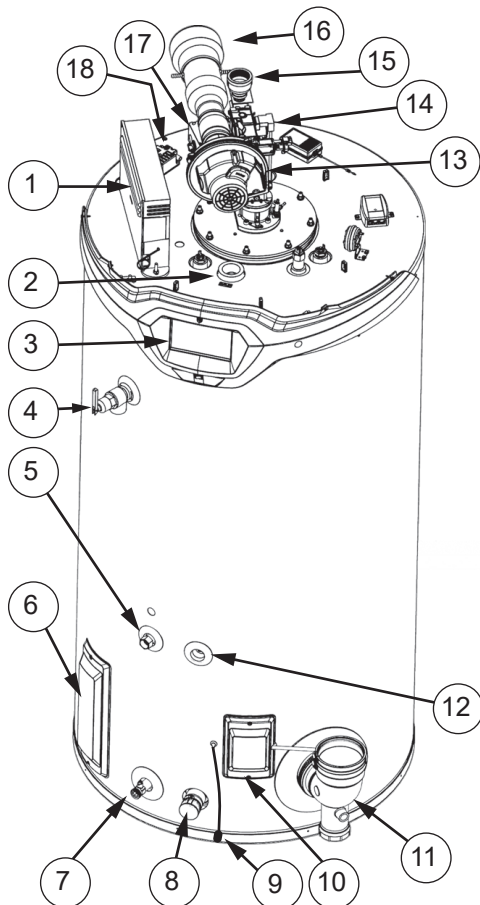

Figure 11. Right Side

1. **Control boards enclosure.** See *Figure 5*, *Figure 6*, and *Figure 7* (page 12) for description.
2. **Water outlet - 1 1/2" NPT connection.**
3. **User Interface Module (UIM).** The UIM includes the display circuit board and the control system's LCD Touch Display. Used to adjust various user settings and view operational information. See *Control System Operation* (page 65)
4. **Temperature-Pressure Relief Valve.** See *Temperature-Pressure Relief Valve* (page 22).
5. **Lower Temperature Probe, 1 of 2 temperature probes.** The water heater's control system monitors this probe to detect water temperature in the lower portion of the storage tank.
6. **Clean-out access panel.** Covers water heater clean-out opening and ASME plate where applicable.
7. **Water heater drain valve.**
8. **Water inlet connection - 1 1/2" NPT connection.**
9. **Leak Detection Module.** This feature senses the buildup of water in the vicinity of the appliance. (Must be plugged in to operate the unit).
10. **Blocked Exhaust (vent) switch.** Normally closed contacts that open on a rise in pressure. This switch is used to ensure that the Exhaust (vent) piping connected to the water heater is not restricted. The control system monitors this switch and will disable heating operation if its contacts are open during a heating cycle.
11. **Vent connection (exhaust/condensate elbow) - Aluminum.**
12. **Recirculation loop return connection - 3/4" NPT.**
13. **Combustion Blower.**
14. **Water heater Gas Valve.**
15. **Supply gas line connection.** See the requirements for the supply gas line in *Table 4* (page 18) and *Table 5* (page 18).
16. **Intake air connection - PVC.**
17. **120 VAC junction box.** Incoming power supply, ground connections, and other field installed electrical connections are made here. See *Power Supply* (page 21) and *Power Supply Connections* (page 53) .
18. **Spark Ignition Transformer.** When energized, sends the electrical current to the spark igniter.
19. **Optional BMS Module.** This feature enables the heater to communicate with a building management system. *Not shown/visible.

RECOVERY AND STORAGE CAPACITIES

Model	U.S. Gallons	Liters
60 gallon	60	227
100 gallon	100	379
119 gallon	119	451

Model	U.S. Gallons/hr & liters/hr at temperature rise indicated														
	Input		°F	30°F	40°F	50°F	60°F	70°F	80°F	90°F	100°F	110°F	120°F	130°F	140°F
	Btu/hr	kW	°C	17°C	22°C	28°C	33°C	39°C	44°C	50°C	56°C	61°C	67°C	72°C	78°C
100	100,000	29	GPH	384	288	230	192	165	144	128	115	105	96	89	82
			LPH	1453	1090	872	726	623	545	484	436	396	363	335	311
120	120,000	35	GPH	461	345	276	230	197	173	154	138	126	115	106	99
			LPH	1743	1308	1046	872	747	654	581	523	475	436	402	374
150	150,000	44	GPH	576	432	345	288	247	216	192	173	157	144	133	123
			LPH	2179	1634	1308	1190	963	817	726	654	594	545	503	467
199	199,900	58	GPH	768	576	461	384	329	294	288	256	230	209	192	177
			LPH	2906	2179	1744	1453	1245	1112	1090	967	872	739	726	671
250	250,000	73	GPH	960	720	576	480	411	360	320	288	262	240	221	206
			LPH	3632	2724	2179	1816	1557	1362	1211	1090	991	908	838	778
251	251,000	74	GPH	963	723	578	481	413	361	321	289	263	241	222	206
			LPH	3647	2735	2188	1823	1563	1368	1214	1094	995	912	842	781
300	300,000	88	GPH	1152	864	661	576	494	432	384	345	314	288	266	247
			LPH	4359	2769	2615	2179	1868	1635	1453	1307	1189	1090	1005	934
400	400,000	117	GPH	1535	1152	921	768	658	576	512	461	419	384	354	329
			LPH	5812	4358	3487	2906	2491	2179	1937	1744	1585	1453	1341	1245
500	500,000	146	GPH	1919	1439	1152	960	823	720	640	576	523	480	443	411
			LPH	7265	5448	4358	3632	3114	2724	2421	2179	1981	1816	1677	1557

Recovery capacities are based on 95% thermal efficiency.

INSTALLATION CONSIDERATIONS

ROUGH IN DIMENSIONS

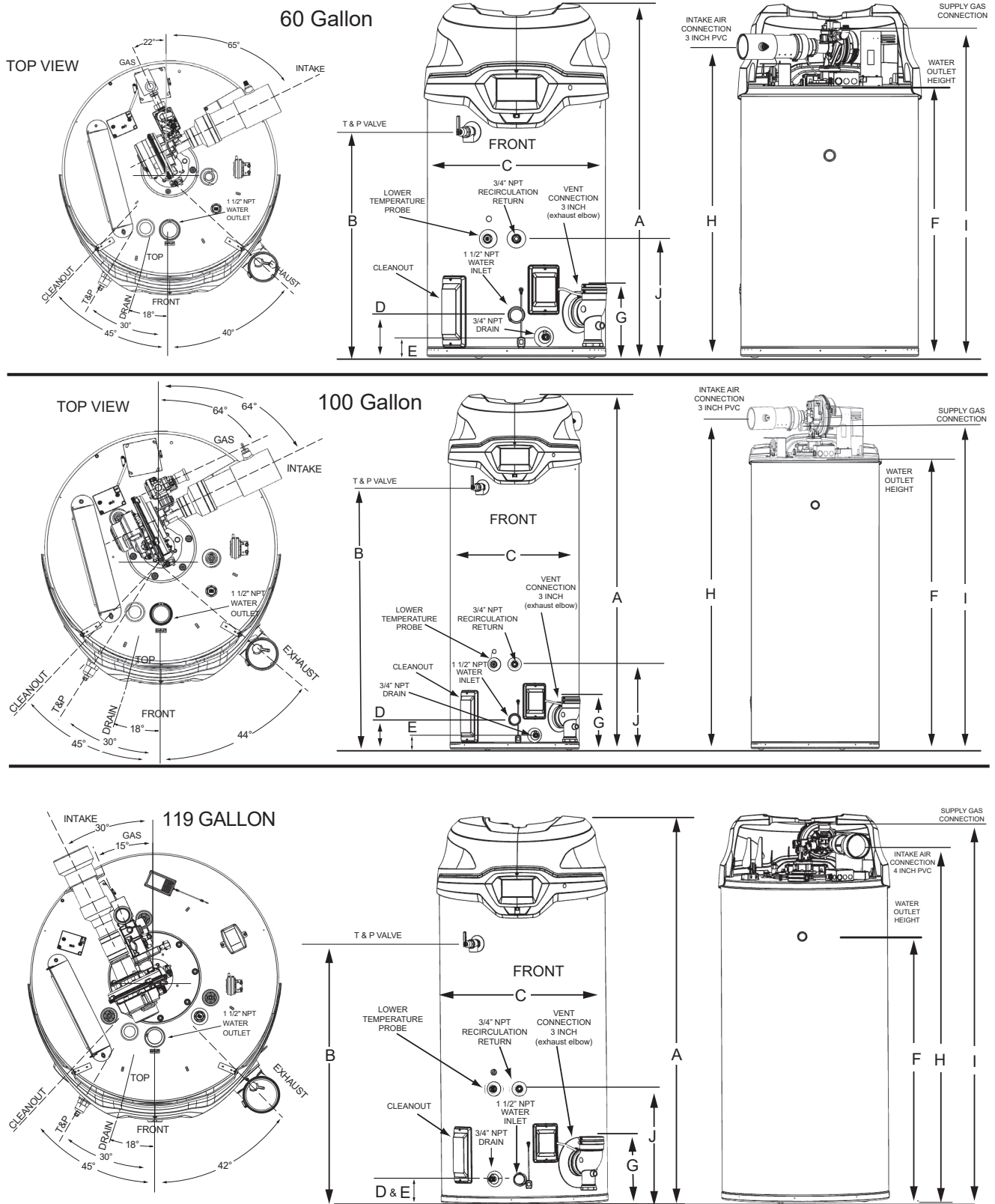

Figure 12. Rough-in Dimensions

Model (Gallon)	Table 3. Dimensions by Model										APPROX. SHIP WEIGHT STD	APPROX. SHIP WEIGHT ASME
	A	B	C	D	E	F	G	H	I	J	LBS (KG)	LBS (KG)
	in (cm)	in (cm)	in (cm)	in (cm)	in (cm)	in (cm)	in (cm)	in (cm)	in (cm)	in (cm)		
60	55-1/2 (141)	35 (88.9)	27-3/4 (70.5)	6-5/16 (16)	3 (7.62)	42-1/4 (107.32)	11-1/4 (28.6)	48-1/2 (123.2)	53-1/2 (135.9)	18-1/4 (46.36)	460 (208)	490 (220)
100	76-1/2 (194.9)	56-3/8 (143.2)	27-3/4 (70.5)	6-5/16 (16)	3 (7.62)	64 (162.6)	11-1/4 (28.6)	70 (177.8)	75-1/2 (191.8)	18-1/4 (46.36)	523 (237)	553 (251)
119	75-3/4 (197.5)	52 (132)	33-1/8 (84.1)	4-3/4 (12.1)	4-3/4 (12.1)	63-1/8 (160.3)	12-3/4 (32.4)	69-1/4 (175.9)	74-1/2 (189.2)	23 (58.4)	855 (388)	855 (388)

These designs comply with the current edition of the *American National Standard for Gas Fired Water Heaters, Volume III, ANSI Z21.10.3-CSA 4.3*. The 100K-400K input water heaters are Automatic Circulating Tank or Automatic Storage Water Heaters. The 500K-input water heater is an Automatic Circulating Tank or Automatic Instantaneous water heater.

Table 4. Fuel Type/Connection Size by Model			
† MODEL	SERIES	NATURAL GAS	PROPANE GAS
60 Gallon	410	3/4" NPT	3/4" NPT
100 Gallon	410	3/4" NPT	3/4" NPT
119 Gallon	410	1 1/4" NPT	1 1/4" NPT

† Depending on the installed equivalent length, and/or the number of appliances connected, the supply gas line size may have to be increased beyond the minimum required sizes. See *Gas Line Sizing* (page 51).

Table 4 shows connections sizes only. Depending on the installed equivalent length, and/or the number of appliances connected, the supply gas line size may have to be increased beyond the minimum required sizes. See *Gas Line Sizing* (page 51).

Table 5. Gas Pressure Requirement						
Model	*Manifold Pressure		Minimum Supply Pressure		Maximum Supply Pressure	
	Natural Gas	Propane Gas	Natural Gas	Propane Gas	Natural Gas	Propane Gas
60G	0" W. C. (0 kPa)	0" W. C. (0 kPa)	3.5" W. C. (0.87 kPa)	8.0" W. C. (1.99 kPa)	14" W. C. (3.49 kPa)	14" W. C. (3.49 kPa)
100G	0" W. C. (0 kPa)	0" W. C. (0 kPa)	3.5" W. C. (0.87 kPa)	8.0" W. C. (1.99 kPa)	14" W. C. (3.49 kPa)	14" W. C. (3.49 kPa)
119G	0" W. C. (0 kPa)	0" W. C. (0 kPa)	3.5" W. C. (0.87 kPa)	8.5" W. C. (1.99 kPa)	14" W. C. (3.49 kPa)	14" W. C. (3.49 kPa)

* The manifold pressure is the factory setting and is not adjustable. A negative pressure will be seen with just the blower running without the Gas Control Valve open.

LOCATING THE WATER HEATER

Carefully choose a location for the new water heater. The placement is a very important consideration for the safety of the occupants in the building and for the most economical use of the water heater.

CAUTION

Property Damage Hazard



Over time, the tank and fittings of the water heater can begin to leak and cause water damage.

- Locate the water heater near an adequate drain and in an area where water leakage from the heater or connections will not result in damage to the area or the lower floors of the structure.
- Install the water heater in a drain pan.

Whether replacing an existing water heater or installing the water heater in a new location observe the following critical points:

1. The water heater must be located indoors.
2. The water heater must not be located in an area where it will be subject to freezing temperatures.
3. Locate the water heater so it is protected and not subject to physical damage by a moving vehicle.
4. Locate the water heater on a level surface.
5. Locate the water heater near a floor drain. The water heater should be located in an area where leakage of the tank or connections will not result in damage to the area adjacent to the water heater or to lower floors of the structure. When such locations cannot be avoided, it is recommended that a metal drain pan, adequately drained, be installed under the water heater.

6. Locate the water heater close to the point of major hot water usage.
7. Locate the water heater close to a 120 VAC power supply. See *Power Supply* (page 21) for requirements.
8. Locate the water heater where an adequate supply of fresh air for combustion and ventilation can be obtained. See *Air Requirements* (page 25).
9. Locate the water heater where the vent and intake-air piping, when installed, will remain within the maximum equivalent lengths allowed. See (page 31).
10. Do not locate the water heater where noise (such as the Combustion Blower) during normal operation will be objectionable in adjacent areas.
11. Do not locate the water heater where the subsequent installation of the vent (exhaust) or intake-air terminations would be objectionable due to noise at the termination(s). This includes locations close to or across from windows and doors. See *Venting Installation* (page 30).

⚠ WARNING

Fire or Explosion Hazard



- Do not store or use gasoline or other flammable vapors and liquids in the vicinity of this or any other appliance.
- Avoid all ignition sources if you smell gas.
- Do not expose water heater controls to excessive gas pressure.
- Use only the gas shown on the water heater rating label.
- Maintain required clearances to combustibles.
- Keep ignition sources away from faucets after extended periods of non-use.

Read instruction manual before installing, using or servicing water heater.

There is a risk in using fuel burning appliances such as gas water heaters in rooms, garages or other areas where gasoline, other flammable liquids or engine driven equipment or vehicles are stored, operated or repaired. Flammable vapors are heavy and travel along the floor and may be ignited by the water heater's igniter or Main Burner flames causing fire or explosion.

Flammable items, pressurized containers or any other potential fire hazardous articles must never be placed on or adjacent to the water heater.

Clearance to Combustible Materials

The water heaters covered in this manual are approved for installation on combustible flooring. The clearance to combustible and non combustible construction materials is 0 inches on the back and sides of the water heater. These water heaters are also approved for installation in an alcove.

When the water heater is installed directly on carpeting, the water heater shall be installed on a metal or wood panel extending beyond the full width and depth of the water heater by at least 3 in (76.2 mm) in any direction or, if the water heater is installed in an alcove or closet, the entire floor shall be covered by the panel. The panel must be strong enough to carry the weight of the heater when full of water.

Note: Adequate clearance for servicing should be maintained on all installations. See *Service Clearance* below.

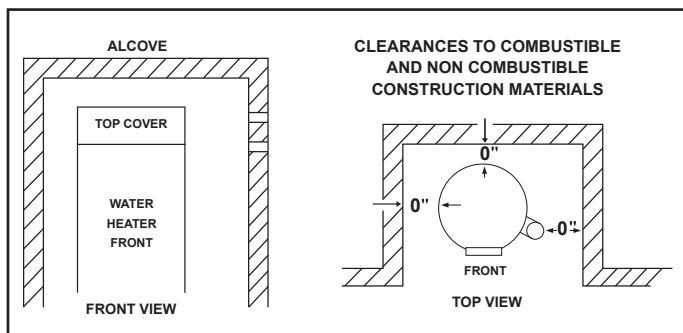

Figure 13. Clearances

Service Clearance

A service clearance of 24 inches (61 cm) should be maintained from serviceable parts such as the T&P valve, control system components, gas valve, clean out opening, drain valve, the vent connection (exhaust/condensate elbow) and the condensate drain. Leave as much room as possible above the water heater and near the exhaust elbow for this reason.

Intake Air and Vent Pipe Clearances

The minimum clearance from combustible materials for the vent (exhaust) and intake-air piping shall be 0 inches. Vent or intake-

air piping passing through a combustible wall or ceiling must be a continuous run (no joints).

OPTIONAL TERMINATIONS

The water heaters covered by this manual can be installed in a Direct Vent configuration using optional concentric or low profile terminations.

See *Low Profile Vent Installation* (page 44), and *Low Profile Vent Installation* (page 44).

Concentric and low profile terminations must be ordered separately. Contact Technical Support for assistance in ordering the concentric terminations or low profile vent terminations. See the contact information label on the water heater.

HARD WATER

Where hard water conditions exist, water softening or the threshold type of water treatment is recommended. This will protect the dishwashers, coffee urns, water heaters, water piping and other equipment.

See *Maintenance* (page 79) for sediment and lime scale removal procedures.

CIRCULATION PUMPS

A circulating pump is used when a system requires a circulating loop or there is a storage tank used in conjunction with the water heater. The tank is provided with a 3/4" NPT recirculation loop return connection. See *Figure 8* through *Figure 11* (pages 14 and 15) for its location. See *Water Piping Diagrams* (page 105) for the installation location of circulating pumps.



See *Circulation Pump Wiring Diagrams* (page 101) for electrical hookup information. Install in accordance with the current edition of the *National Electrical Code, NFPA 70* or the *Canadian Electrical Code, CSA C22.1*.

Stainless Steel circulating pumps are recommended for use with commercial water heaters.

See the circulating pump manufacturer's instructions for its operation, lubrication and maintenance instructions.

INSULATION BLANKETS

Insulation blankets are available to the general public for external use on gas water heaters but are not necessary with these products. The purpose of an insulation blanket is to reduce the standby heat loss encountered with storage tank heaters. The water heaters covered by this manual meet or exceed the *Energy Policy Act* standards with respect to insulation and standby heat loss requirements, making an insulation blanket unnecessary.

 WARNING	
Breathing Hazard - Carbon Monoxide Gas	
	<ul style="list-style-type: none">• Do not obstruct water heater air intake with insulating blanket.• Gas and carbon monoxide detectors are available.• Install water heater in accordance with the instruction manual.
Breathing carbon monoxide can cause brain damage or death. Always read and understand instruction manual.	

Should you choose to apply an insulation blanket to this heater, you should follow these instructions. See *Features and Components* (page 10) for identification of components mentioned below. Failure to follow these instructions can restrict the air flow required for proper combustion, potentially resulting in fire, asphyxiation, serious personal injury or death.

- **Do not** apply insulation to the top of the water heater, as this will interfere with safe operation of the blower assembly.
- **Do not** cover the control system LCD on top of the water heater.
- **Do not** cover the Temperature-Pressure Relief Valve.
- **Do not** cover the instruction manual. Keep it on the side of the water heater or nearby for future reference.
- **Do** obtain new warning and instruction labels from the manufacturer for placement on the blanket directly over the existing labels.
- **Do** inspect the insulation blanket frequently to make certain it does not sag, thereby obstructing combustion air flow.

INSTALLATION REQUIREMENTS

GAS SUPPLY SYSTEMS

Low pressure building gas supply systems are defined as those systems that cannot under any circumstances exceed 14" W.C. (1/2 PSI Gauge). These systems do not require pressure regulation. Measurements should be taken to ensure that gas pressures are stable and fall within the requirements stated on the water heater rating plate. Readings should be taken with all gas burning equipment off (static pressure) and with all gas burning equipment running at maximum rate (dynamic pressure). The gas supply pressure must be stable within 1.5" W.C. from static to dynamic pressure to provide good performance. Pressure drops that exceed 1.5" W.C. can cause rough starting, noisy combustion or nuisance outages. Increases or spikes in static pressure during off cycles may cause failure to ignite or in severe cases damage to appliance gas valves. If your low pressure system does NOT meet these requirements, the installer is responsible for the corrections.

High Pressure building supply systems use pressures that exceed 14" W.C. (1/2 PSI Gauge). These systems must use field-supplied regulators to lower the gas pressure to less than 14" W.C. (1/2 PSI Gauge). Water heaters require gas regulators that are properly sized for the water heater input and deliver the rating plate specified pressures. Gas supply systems where pressure exceeds 5 PSI often require multiple regulators to achieve desired pressures. Systems in excess of 5 PSI building pressure should be designed by gas delivery professionals for best performance. Water heaters connected to gas supply systems that exceed 14" W.C. (1/2 PSI Gauge) at any time must be equipped with a gas supply regulator.

60/100/119 gallon model units require a minimum gas supply pressure of 3.5" W.C. for natural gas and 8" W.C. for propane gas. The supply pressure should never fall below 3.5" W.C. for natural gas and 8" W.C. for propane gas.

The minimum supply pressure is measured while gas is flowing (dynamic pressure). The supply pressure should never fall below the minimums. The supply pressure should be measured with all gas fired appliances connected to the common main firing at full capacity. If the supply pressure drops more than 1.5" W.C. as gas begins to flow to the water heater, the supply gas system, including the gas line and/or the gas regulator, might be restricted or undersized. See *Supply Gas Regulator* (page 21), the requirements for the supply gas line in *Table 4* (page 18) and *Table 5* (page 18), and the instructions in *Supply Gas Line Installation* (page 51). The gas valve on all models has a maximum gas supply pressure limit of 14" W.C. The maximum supply pressure is measured while gas is not flowing (static pressure).

SUPPLY GAS REGULATOR

1. The maximum allowable gas supply pressure for this water heater is 14.0" W. C. (3.49 kPa) for natural and propane gas. Install a positive lock-up gas pressure regulator in the gas supply line if inlet gas pressure can exceed these pressures at any time.
2. If a positive lock-up regulator is required follow these instructions:
 - A. Positive lock-up gas pressure regulators must be rated at or

above the input Btu/hr rating of the water heater they supply.

- B. Supply gas regulators shall have inlet and outlet connections not less than the minimum supply gas line size for the water heater they supply. See *Table 20* (page 51) and *Table 21* (page 52).
- C. Positive lock-up gas pressure regulator(s) should be installed no closer than 3 feet (1 meter) and no farther than 8 feet (2.4 meters) from the water heater's inlet gas connection.
3. After installing the positive lock-up gas pressure regulator(s) an initial nominal supply pressure setting of 7.0" W.C. while the water heater is operating is recommended and will generally provide good water heater operation. Some additional adjustment maybe required later to maintain a steady gas supply pressure.

When installing multiple water heaters in the same gas supply system it is recommended that individual positive lock-up gas pressure regulators be installed at each unit.

Ensure that the gas line is properly supported to reduce the weight on the gas train support.

POWER SUPPLY

The water heaters covered in this manual require a 120 VAC, 1Ø (single phase), 60Hz, 15 amp power supply and must also be electrically grounded in accordance with local codes or, in the absence of local codes, with the *National Electrical Code, ANSI/NFPA 70* or the *Canadian Electrical Code, CSA C22.1*.

Dedicated Power Wiring and Breakers

Dedicated power supply wires, neutral wires, ground wiring and dedicated circuit breakers often prevent electrical line noise and are required when installing the water heater.

Note: This water heater should not be connected to an electrical supply with a Ground Fault Circuit Interrupter (GFCI) or Arc Fault Circuit Interrupter (AFCI) with Integral GFCI protection as defined in *NFPA 70, CSA C22.1* and *UL 943*.

Power Fluctuations and Electrical Noise

The water heater's control system requires a source of stable clean electricity for proper operation. Connecting the water heater to a branch circuit that is subject to fluctuations in voltage level or electrical line noise such as EMI (electro magnetic interference) or RFI (radio frequency interference) may cause erratic control system operation and malfunction.

A high quality power supply filter/suppressor are commercially available and must be installed if the above conditions exist.

Note: Malfunctions caused by the power supply and the costs to install power supply filters are not covered under the limited warranty.

MIXING VALVES

⚠ DANGER

Burn Hazard

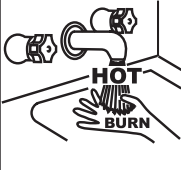

Because of the increased risk from scalding, if you set the water heater's gas control knob higher than 120°F (49°C), install thermostatic point-of-use mixing valves at each point of use. Due to the increased risk of scalding, do not set the temperature of the thermostatic mixing valves above 120°F (49°C).

Water heated to a temperature which will satisfy clothes washing, dish washing, and other sanitizing needs can scald and cause permanent injury upon contact. Short repeated heating cycles caused by small hot water uses can cause temperatures at the point of use to exceed the water heater's temperature setting by up to 20°F (11°C).

Some people are more likely to be permanently injured by hot water than others. These include the elderly, children, the infirm and the physically/mentally disabled. *Table 6* shows the approximate time-to-burn relationship for normal adult skin. If anyone using hot water provided by the water heater being installed fits into one of these groups or if there is a local code or state law requiring a certain water temperature at the point of use, then special precautions must be taken.

In addition to using the lowest possible temperature setting that satisfies the demand of the application a means, such as a thermostatic point-of-use mixing valve, for example, can be used at the hot water taps used by these people to reduce the water temperature.

Check State and/or local codes for thermostatic point-of-use mixing valve requirements and installation practices.

Mixing valves are available at plumbing supply stores. Consult a Qualified Installer or Service Agency. Follow mixing valve manufacturer's instructions for installation of the valves.

Water Temperature °F (°C)	Time for 1st Degree Burn (Less Severe Burns)	Time for Permanent Burns 2nd & 3rd Degree (Most Severe Burns)
110 (43)	(normal shower temp.)	
116 (47)	(pain threshold)	
116 (47)	35 minutes	45 minutes
122 (50)	1 minute	5 minutes
131 (55)	5 seconds	25 seconds
140 (60)	2 seconds	5 seconds
149 (65)	1 second	2 seconds
154 (68)	instantaneous	1 second

(U.S. Government Memorandum, C.P.S.C., Peter L. Armstrong, Sept. 15, 1978)

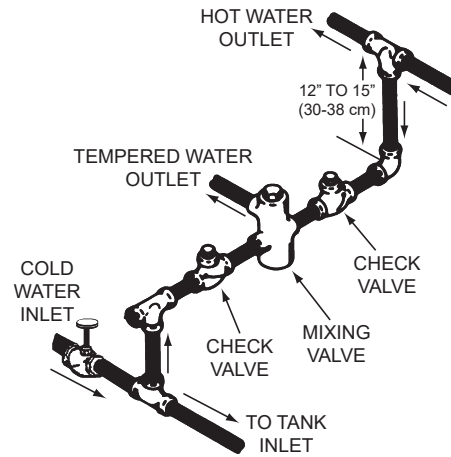

Figure 14. Mixing Valve

DISH-WASHING MACHINES

Requirements are designed to operate with water flow pressures between 15 and 25 pounds per square inch (103 kPa and 173 kPa). Flow pressures above 25 pounds per square inch (173 kPa), or below 15 pounds per square inch (103 kPa), will result in improperly sanitized dishes. Where pressures are high, a water pressure reducing or flow regulating control valve should be used in the 180°F (82°C) line to the dish-washing machine and should be adjusted to deliver water pressure between these limits.

The *National Sanitation Foundation* also recommends circulation of 180°F (82°C) water. The circulation should be just enough to provide 180°F (82°C) water at the point of take-off to the dish-washing machine.

Adjust flow by throttling a full port ball valve installed in the circulating line on the outlet side of the pump. Never throttle flow on the suction side of a pump. See *Water Piping Diagrams* (page 105).

Note: To comply with *NSF Standard 5* installation requirements the bottom of the water heater must be sealed to the floor with a silicone based sealant or elevated 6 inches above the floor.

CLOSED WATER SYSTEMS

Water supply systems may, because of code requirements or such conditions as high line pressure, among others, have installed devices such as pressure reducing valves, check valves, and back flow preventers. Devices such as these cause the water system to be a closed system.

THERMAL EXPANSION

A properly sized and pressurized thermal expansion tank must be installed on all closed systems to control the harmful effects of thermal expansion. Contact a local plumbing service agency to have a thermal expansion tank installed.

See *Water Line Connections* (page 54) and the *Water Piping Diagrams* (page 105).

TEMPERATURE-PRESSURE RELIEF VALVE

This water heater is provided with a properly rated/sized and certified combination Temperature-Pressure Relief Valve (T&P valve) by the manufacturer. The valve is certified by a nationally recognized testing laboratory that maintains periodic inspection of production of

listed equipment of materials as meeting the requirements for **Relief Valves for Hot Water Supply Systems, ANSI Z21.22 • CSA 4.4**, and the code requirements of **ASME**.

If replaced, the new T&P valve must meet the requirements of local codes, but not less than a combination Temperature-Pressure Relief Valve rated/sized and certified as indicated in the above paragraph. The new valve must be marked with a maximum set pressure not to exceed the marked hydrostatic working pressure of the water heater (150 psi = 1,035 kPa) and a discharge capacity not less than the water heater Btu/hr or kW input rate as shown on the water heater's model rating label.

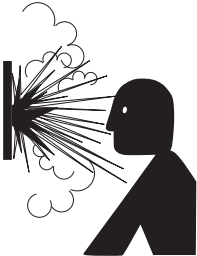
⚠ WARNING	
Explosion Hazard	
	<p>Normal operation of the water heater can cause it to become sufficiently over-heated and/or over-pressurized that it can explode, resulting in property damage, sever injury, or death.</p> <p>To avoid this hazard, you must install a properly-sized temperature-pressure relief valve in opening provided.</p> <ul style="list-style-type: none"> The temperature-pressure relief valve must comply with ANSI Z21.22-CSA 4.4 and ASME code. Do not plug, block, or cap the discharge line.

Note: In addition to the factory-installed Temperature-Pressure Relief Valve on the water heater, each remote storage tank that may be installed and piped to a water heating appliance must also have its own properly sized, rated and approved Temperature-Pressure Relief Valve installed. Contact Technical Support for assistance in sizing a Temperature-Pressure Relief Valve for remote storage tanks. See the contact information label on the water heater.

For safe operation of the water heater, the Temperature-Pressure Relief Valve must not be removed from its designated opening nor plugged. The Temperature-Pressure Relief Valve must be installed directly into the fitting of the water heater designed for the relief valve. Install discharge piping so that any discharge will exit the pipe 6 inches above an adequate floor drain, or external to the building. In cold climates it is recommended that it be terminated at an adequate drain inside the building. Be certain that no contact is made with any live electrical part. The discharge opening must not be blocked or reduced in size under any circumstances. Excessive length, over 30 feet (9.14 m), or use of more than four elbows can cause restriction and reduce the discharge capacity of the valve.

No valve or other obstruction is to be placed between the Temperature-Pressure Relief Valve and the tank. Do not connect discharge piping directly to the drain. Position the end of the discharge pipe directly above the drain, pointing downward, with an air gap of 6" (15.3 cm) above a suitable drain. To prevent bodily injury, hazard to life, or property damage, the relief valve must be allowed to discharge water in adequate quantities should circumstances demand. If the discharge pipe is not connected to a drain or other suitable means, the water flow may cause property damage or personal injury.

⚠ CAUTION	
Property Damage Hazard	
	<p>While the water heater is in routine operation, it can release hot water from the temperature-pressure relief valve discharge pipe in quantities that could cause damage to the surroundings.</p> <p>Locate the water heater near an adequate drain and in an area where water from the temperature-pressure relief valve discharge pipe will not result in damage to the area of the lower floors of the structure.</p>

T&P Valve Discharge Pipe Requirements:

- Shall not be smaller in size than the outlet pipe size of the valve, or have any reducing couplings or other restrictions.
- Shall not be plugged or blocked.
- Shall not be exposed to freezing temperatures.
- Shall be of material listed for hot water distribution.
- Shall be installed so as to allow complete drainage of both the Temperature-Pressure Relief Valve and the discharge pipe.
- Must terminate six inches above a floor drain or external to the building. In cold climates, it is recommended that the discharge pipe be terminated at an adequate drain inside the building.
- Shall not have any valve or other obstruction between the relief valve and the drain.

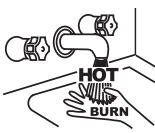
⚠ DANGER	
Burn Hazard	
	<p>The discharge water from the drain valve is hot enough to cause burns.</p> <p>Keep your hands clear of the drain valve discharge outlet.</p>

The Temperature-Pressure Relief Valve must be manually operated at least twice a year. **Caution should be taken to ensure that (1) no one is in front of or around the outlet of the Temperature-Pressure Relief Valve discharge line, and (2) the water manually discharged will not cause any bodily injury or property damage because the water may be extremely hot.** If after manually operating the valve, it fails to completely reset and continues to release water, immediately close the cold water inlet to the water heater, follow the draining instructions in this manual, and replace the Temperature-Pressure Relief Valve with a properly rated/sized new one.

Note: The purpose of a Temperature-Pressure Relief Valve is to prevent excessive temperatures and pressures in the storage tank. The T&P valve is not intended for the constant relief of thermal expansion. A properly sized thermal expansion tank must be installed on all closed systems to control thermal expansion. See **Closed Water Systems** (page 22) and **Thermal Expansion** (page 22).

If you do not understand these instructions or have any questions regarding the Temperature-Pressure Relief Valve contact Technical Support for assistance. See the contact information label on the water heater.

⚠ CAUTION	
Property Damage Hazard	
	<p>While the water heater is in routine operation, it can release hot water from the temperature-pressure relief valve discharge pipe in quantities that could cause damage to the surroundings.</p> <p>Locate the water heater near an adequate drain and in an area where water from the temperature-pressure relief valve discharge pipe will not result in damage to the area of the lower floors of the structure.</p>

T&P Valve Discharge Pipe Requirements:

- Shall not be smaller in size than the outlet pipe size of the valve, or have any reducing couplings or other restrictions.
- Shall not be plugged or blocked.
- Shall not be exposed to freezing temperatures.
- Shall be of material listed for hot water distribution.
- Shall be installed so as to allow complete drainage of both the Temperature-Pressure Relief Valve and the discharge pipe.
- Must terminate a maximum of 30 cm (11.8 inches) above a floor drain or external to the building. In cold climates, it is recommended that the discharge pipe be terminated at an adequate drain inside the building.
- Shall not have any valve or other obstruction between the relief valve and the drain.

⚠ DANGER	
Burn Hazard	
	<p>The discharge water from the drain valve is hot enough to cause burns.</p> <p>Keep your hands clear of the drain valve discharge outlet.</p>

The Temperature-Pressure Relief Valve must be manually operated at least twice a year. Caution should be taken to ensure that (1) no one is in front of or around the outlet of the Temperature-Pressure Relief Valve discharge line, and (2) the water manually discharged will not cause any bodily injury or property damage because the water may be extremely hot. If after manually operating the valve, it fails to completely reset and continues to release water, immediately close the cold water inlet to the water heater, follow the draining instructions in this manual, and replace the Temperature-Pressure Relief Valve with a properly rated/sized new one.

Note: The purpose of a Temperature-Pressure Relief Valve is to prevent excessive temperatures and pressures in the storage tank. The T&P valve is not intended for the constant relief of thermal expansion. A properly sized thermal expansion tank must be installed on all closed systems to control thermal expansion. See *Closed Water Systems* (page 22) and *Thermal Expansion* (page 22).

If you do not understand these instructions or have any questions regarding the Temperature-Pressure Relief Valve contact Technical Support for assistance. See the contact information label on the water heater.

CONDENSATE DRAIN

The water heaters covered in this manual are condensing appliances and require a building drain to be located in close proximity to allow the condensate to drain safely.

Condensate drains from the water heater at the exhaust/condensate elbow located at the bottom. The field-installed condensate drain line must not be elevated above the condensate drain connection on the exhaust/condensate elbow. See *Figure 15* (page 24).

If the condensate does not drain properly it will build up in the exhaust (vent) elbow. This will restrict the flow of flue gases and cause the Blocked Exhaust pressure switch to open its contacts. The control system monitors all pressure switches, if the Blocked Exhaust Switch contacts are open the control system will lockout and disable heating operation. The “Blocked Exhaust” Fault message will be displayed on the control system’s LCD. See *Fault and Alert Conditions* (page 86).

The Condensate Clean-out Cap must be on and tight when unit is in operation.

The exhaust elbow has a built in condensate trap. Do not install an additional trap in the condensate drain piping. See *Figure 15* (page 24).

Note: If the “Blocked Exhaust” Fault message is ever displayed on the control system LCD, check the condensate drain first and ensure it is not blocked.

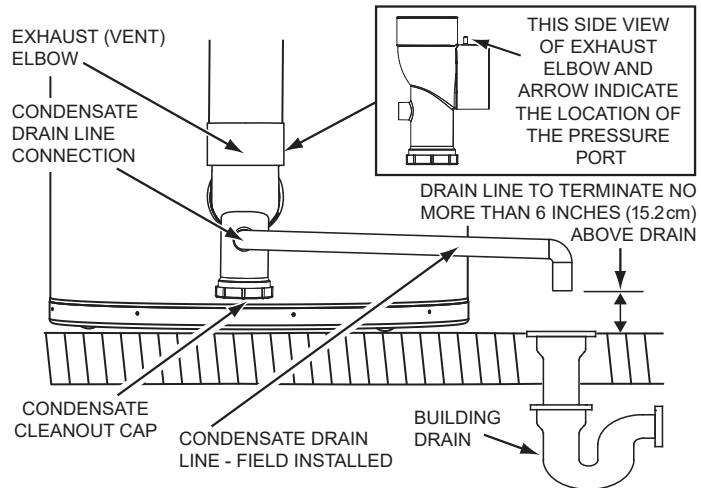

Figure 15. Exhaust/Condensate Elbow

Secondary Condensate Drain

- The overflow tee must be oriented upwards. See *Figure 16*.
- Route the overflow pipe to a drain pan or appropriate drain.

The secondary condensate drain incorporates an integrated drain path designed to discharge water externally in the event of internal coil perforation or failure within the heat exchanger. This feature enables early detection of coil leakage, allowing corrective action to be taken prior to system damage or operational hazards.

This feature functions strictly as an indicator of internal leakage and is not intended to contain, prevent, or mitigate coil failure. Upon observation of water discharge through the drain, the appliance must be immediately inspected and serviced by qualified personnel. The manufacturer assumes no responsibility for property damage, personal injury, or performance issues resulting from failure to respond appropriately to evidence of leakage or from improper installation, maintenance, or operation.

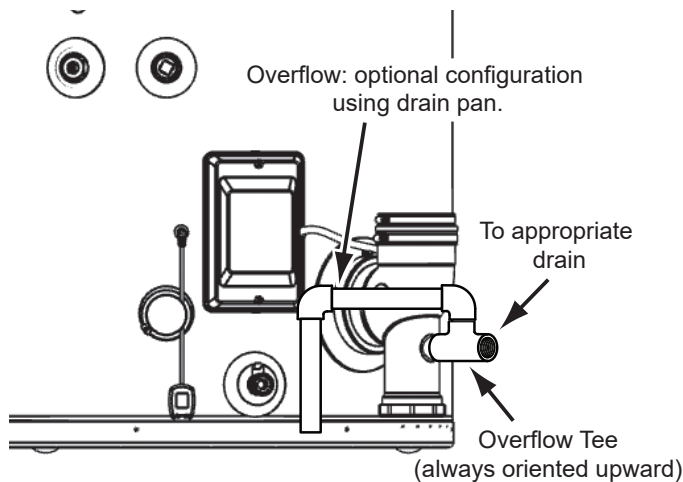

Figure 16. Secondary Condensate Drain

Condensate Drain Water Trap

Do not remove the factory installed exhaust/condensate elbow for any reason. See *Figure 15*. The water heater's vent pipe is under a slight positive pressure while unit is in operation. The water trap prevents flue gases from escaping into the installed space. The exhaust elbow has a "built in" condensate trap. Do not install an additional trap in the condensate drain piping. See *Figure 15* (page 24) and *Condensate Drain Installation* (page 50).

Condensate PH Level

The condensate drains from the water heater's covered in this manual have pH levels between 4.3 and 5.0. Install a commercially available neutralizing kit if required by local codes.

Note: pH levels are acidic. Do not connect a metal drain line, such as copper, to the water heater for this reason. See *Condensate Drain Installation* (page 50).

COMBUSTIBLE MATERIAL STORAGE

⚠ WARNING	
Fire or Explosion Hazard	
	<p>Under certain circumstances, the water heater can explode and catch fire, resulting in property damage, personal injury, or death.</p> <p>Do the following to avoid these conditions:</p> <ul style="list-style-type: none"> • Do not store or use gasoline or other flammable vapors and liquids in the vicinity of this or any other appliance. • Avoid all ignition sources if you smell gas. • Do not expose water heater controls to excessive gas pressure. • Use only the gas shown on the water heater rating label. • Maintain required clearances to combustibles. • Keep ignition sources away from faucets after extended periods of non-use.
<p>Read instruction manual before installing, using or servicing water heater.</p>	

Keep appliance area clear and free of combustible materials, gasoline and other flammable vapors and liquids.

CONTAMINATED AIR

⚠ WARNING	
Breathing Hazard - Carbon Monoxide Gas	
	<ul style="list-style-type: none"> • Install water heater in accordance with the Instruction Manual and NFPA 54 or CAN/CSA-B149.1. • To avoid injury, combustion and ventilation air must be taken from outdoors. • Do not place chemical vapor emitting products near water heater.
<p>Breathing carbon monoxide can cause brain damage or death. Always read and understand instruction manual.</p>	

Corrosion of the flue ways and vent system may occur if air for combustion contains certain chemical vapors. Such corrosion may result in failure and risk of asphyxiation.

Combustion air that is contaminated can greatly diminish the life span of the water heater and water heater components such as igniters and burners. Propellants of aerosol sprays, beauty shop supplies, water softener chemicals and chemicals used in dry cleaning processes that are present in the combustion, ventilation or ambient air can cause such damage.

Do not store products of this sort near the water heater. Air which is brought in contact with the water heater should not contain any of these chemicals. If necessary, uncontaminated air should be obtained from remote or outdoor sources. The limited warranty is voided when failure of water heater is due to a corrosive atmosphere. (See limited warranty for complete terms and conditions).

If the water heater will be used in beauty shops, barber shops, cleaning establishments, or self-service laundries with dry cleaning equipment, it is imperative that the water heater(s) be installed in a Direct Vent configuration so that all air for combustion is derived directly from the outdoor atmosphere through a sealed intake-air pipe. See *Venting Installation* (page 30).

AIR REQUIREMENTS

⚠ WARNING	
Breathing Hazard - Carbon Monoxide Gas	
	<ul style="list-style-type: none"> • Install water heater in accordance with the Instruction Manual and NFPA 54 or CAN/CSA-B149.1. • To avoid injury, combustion and ventilation air must be taken from outdoors. • Do not place chemical vapor emitting products near water heater.
<p>Breathing carbon monoxide can cause brain damage or death. Always read and understand instruction manual.</p>	

For safe operation an adequate supply of fresh uncontaminated air for combustion and ventilation must be provided.

An insufficient supply of air can cause recirculation of combustion products resulting in contamination that may be hazardous to life. Such a condition often will result in a yellow, luminous burner flame, causing sooting of the combustion chamber, burners and flue tubes and creates a risk of asphyxiation.

Do not install the water heater in a confined space unless an adequate supply of air for combustion and ventilation is brought in to that space using the methods described in Confined Space.

Never obstruct the flow of ventilation air. If you have any doubts or questions at all, call your gas supplier. Failure to provide the proper amount of combustion air can result in a fire or explosion and cause property damage, serious bodily injury or death.

Unconfined Space

An Unconfined Space is one whose volume **is not less than** 50 cubic feet per 1,000 Btu/hr (4.8 cubic meters per kW) of the total input rating of all appliances installed in the space. Rooms communicating directly with the space, in which the appliances are installed, through openings not furnished with doors, are considered a part of the unconfined space.

Makeup air requirements for the operation of exhaust fans, kitchen ventilation systems, clothes dryers and fireplaces shall also be considered in determining the adequacy of a space to provide combustion, ventilation and dilution air.

Unusually Tight Construction

In unconfined spaces in buildings, infiltration may be adequate to provide air for combustion, ventilation and dilution of flue gases. However, in buildings of unusually tight construction (for example, weather stripping, heavily insulated, caulked, vapor barrier, etc.) additional air must be provided using the methods described in **Confined Space**.

Confined Space

A Confined Space is one whose volume **is less than** 50 cubic feet per 1,000 Btu/hr (4.8 cm per kW) of the total input rating of all appliances installed in the space.

Openings must be installed to provide fresh air for combustion, ventilation and dilution in confined spaces. The required size for the openings is dependent on the method used to provide fresh air to the confined space **and** the total Btu/hr input rating of all appliances installed in the space.

Direct Vent Appliances

Appliances installed in a Direct Vent configuration that derive all air for combustion from the outdoor atmosphere through sealed intake-air piping are not factored in the total appliance input Btu/hr calculations used to determine the size of openings providing fresh air into confined spaces.

Exhaust Fans

Where exhaust fans are installed, additional air shall be provided to replace the exhausted air. When an exhaust fan is installed in the same space with a water heater, sufficient openings to provide fresh air must be provided that accommodate the requirements for all appliances in the room and the exhaust fan. Undersized openings will cause air to be drawn into the room through the water heater's vent system causing poor combustion. Sooting, serious damage to the water heater and the risk of fire or explosion may result. It can also create a risk of asphyxiation.

Louvers and Grilles

The free areas of the fresh air openings in the instructions that follow do not take in to account the presence of louvers, grilles or screens in the openings.

The required size of openings for combustion, ventilation and dilution air shall be based on the "net free area" of each opening. Where the free area through a design of louver or grille or screen is known, it shall be used in calculating the size of the opening required to provide the free area specified. Where the louver and grille design and free area are not known, it shall be assumed that wood louvers will have 25% free area and metal louvers and grilles will have 75% free area. Non motorized louvers and grilles shall be fixed in the open position.

FRESH AIR OPENINGS FOR CONFINED SPACES

The following instructions shall be used to calculate the size, number and placement of openings providing fresh air for combustion, ventilation and dilution in confined spaces. The illustrations shown in this section of the manual are a reference for the openings that provide fresh air into confined spaces only. **Do not** refer to these illustrations for the purpose of vent installation. See **Venting Installation** (page 30) for complete venting installation instructions.

Outdoor Air Through Two Openings

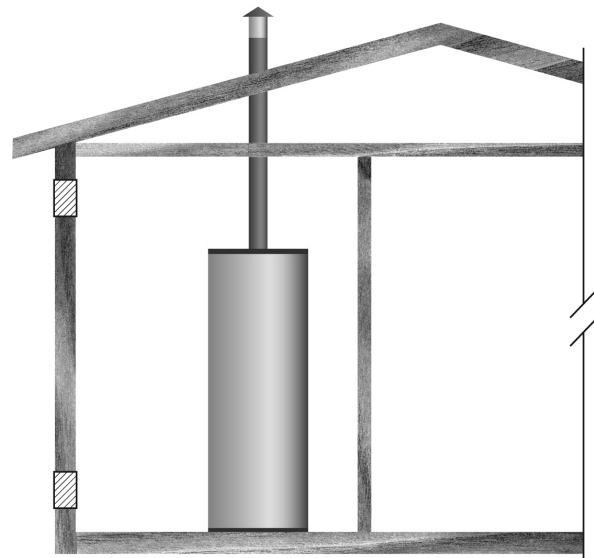

Figure 17. Outdoor Air Through Two Openings

The confined space shall be provided with two permanent openings, one commencing within 12 inches (30 cm) of the top and one commencing within 12 inches (30 cm) of the bottom of the enclosure. The openings shall communicate directly with the outdoors. See **Figure 17**.

Each opening shall have a minimum free area of one square inch per 4,000 Btu/hr (550 mm² per kW) of the aggregate input rating of all appliances installed in the enclosure. Each opening shall not be less than 100 square inches (645 cm²).

Outdoor Air Through One Opening

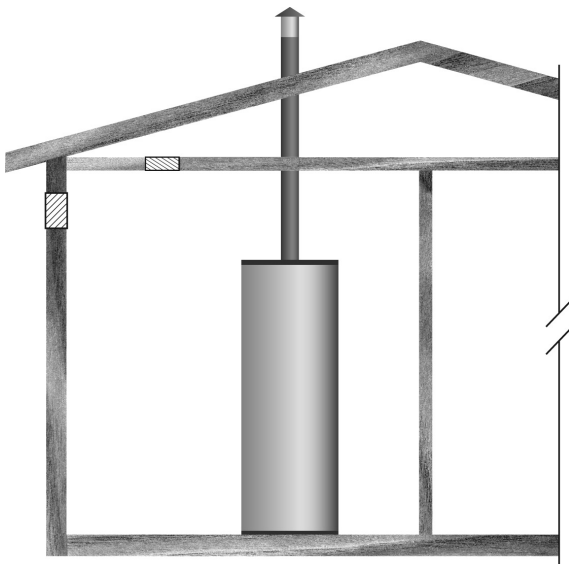

Figure 18. Outdoor Air Through One Opening

Alternatively a single permanent opening, commencing within 12 inches (30 cm) of the top of the enclosure, shall be provided. See *Figure 18*. The water heater shall have clearances of at least 1 inch (2.5 cm) from the sides and back and 6 inches (15 cm) from the front of the water heater. The opening shall directly communicate with the outdoors or shall communicate through a vertical or horizontal duct to the outdoors or spaces that freely communicate with the outdoors and shall have a minimum free area of the following:

One square inch per 3000 Btu/hr (700 mm² per kW) of the total input rating of all appliances located in the enclosure, and

Not less than the sum of the areas of all vent connectors in the space.

Outdoor Air Through Two Horizontal Ducts

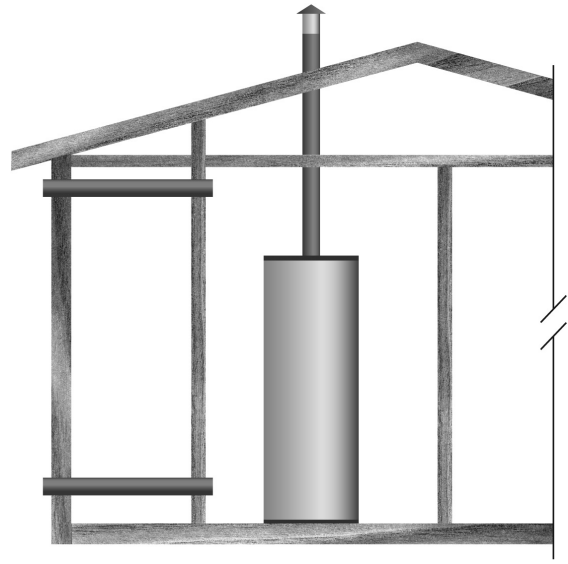

Figure 19. Outdoor Air Through Two Horizontal Ducts

The confined space shall be provided with two permanent horizontal ducts, one commencing within 12 inches (30 cm) of the top and one commencing within 12 inches (30 cm) of the bottom of the enclosure. The horizontal ducts shall communicate directly with the outdoors. See *Figure 19*.

Each duct opening shall have a minimum free area of 1 square inch per 2,000 Btu/hr (1100 mm² per kW) of the aggregate input rating of all appliances installed in the enclosure.

When ducts are used, they shall be of the same cross sectional area as the free area of the openings to which they connect. The minimum dimension of rectangular air ducts shall be not less than 3 inches.

Outdoor Air Through Two Vertical Ducts

The illustrations shown in this section of the manual are a reference for the openings that provide fresh air into confined spaces only.

Do not refer to these illustrations for the purpose of vent installation. See *Venting Installation* (page 30) for complete venting installation instructions.

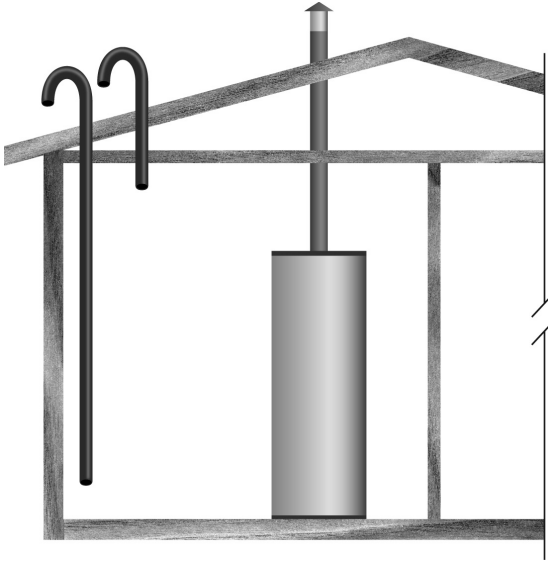

Figure 20. Outdoor Air Through Two Vertical Ducts

The confined space shall be provided with two permanent vertical ducts, one commencing within 12 inches (30 cm) of the top and one commencing within 12 inches (30 cm) of the bottom of the enclosure. The vertical ducts shall communicate directly with the outdoors. See *Figure 20*.

Each duct opening shall have a minimum free area of 1 square inch per 4,000 Btu/hr (550 mm² per kW) of the aggregate input rating of all appliances installed in the enclosure.

When ducts are used, they shall be of the same cross sectional area as the free area of the openings to which they connect. The minimum dimension of rectangular air ducts shall be not less than 3 inches.

Air From Other Indoor Spaces

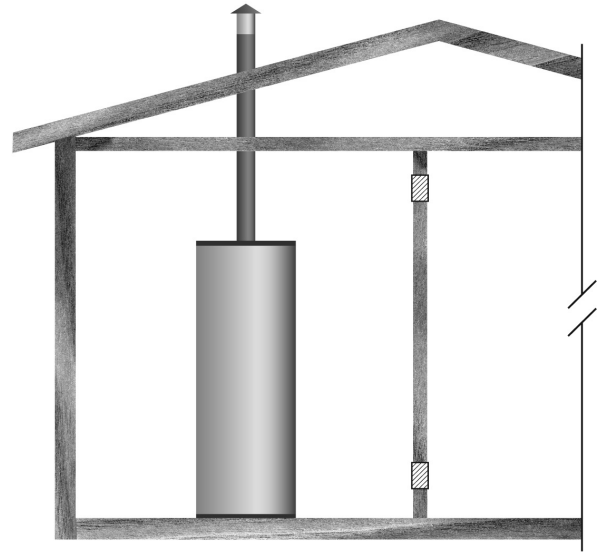

Figure 21. Air From Other Indoor Spaces

The confined space shall be provided with two permanent openings, one commencing within 12 inches (30 cm) of the top and one commencing within 12 inches (30 cm) of the bottom of the enclosure. See *Figure 21*.

Each opening shall communicate directly with an additional room(s) of sufficient volume so that the combined volume of all spaces meets the criteria for an Unconfined Space.

Each opening shall have a minimum free area of 1 square inch per 1,000 Btu/hr (1100 mm² per kW) of the aggregate input rating of all appliances installed in the enclosure. Each opening shall not be less than 100 square inches (645 cm²).

MASSACHUSETTS INSTALLATION REQUIREMENTS

Commonwealth Of Massachusetts

For all side wall terminated, horizontally vented power vent, direct vent, and power direct vent gas fueled water heaters installed in every dwelling, building or structure used in whole or in part for residential purposes, including those owned or operated by the Commonwealth and where the side wall exhaust vent termination is less than seven (7) feet above finished grade in the area of the venting, including but not limited to decks and porches, the following requirements shall be satisfied:

Installing Carbon Monoxide Detectors

At the time of installation of the side-wall horizontal-vented gas-fueled equipment, the installing plumber or gas-fitter shall observe that a hard-wired carbon-monoxide detector, with an alarm and battery back-up, is installed on the floor level where the gas equipment is to be installed. In addition, the installing plumber or gas-fitter shall observe that a battery-operated or hard-wired carbon-monoxide detector, with an alarm, is installed on each additional level of the dwelling, building, or structure served by the side-wall horizontal-vented gas-fueled equipment. It shall be the responsibility of the property owner to secure the services of qualified licensed professionals for the installation of hard-wired carbon-monoxide detectors.

In the event that the side-wall horizontally-vented gas-fueled equipment is installed in a crawl space or an attic, the hard-wired carbon-monoxide detector, with alarm and battery back-up, may be installed on the next adjacent floor level.

In the event that the requirements of this subdivision can not be met at the time of completion of installation, the owner shall have a period of thirty (30) days to comply with the above requirements provided that during said thirty (30) day period, a battery-operated carbon-monoxide detector, with an alarm, shall be installed.

APPROVED CARBON MONOXIDE DETECTORS

Each carbon-monoxide detector as required in accordance with the above provisions shall comply with *NFPA 720* and be *ANSI/UL 2034* listed and *CSA* certified.

Signage

A metal or plastic identification plate shall be permanently mounted to the exterior of the building at a minimum height of eight (8) feet above grade directly in line with the exhaust vent terminal for the horizontally-vented gas-fueled heating appliance or equipment. The sign shall read, in print size no less than one-half (1/2) inch in size, ***“gas vent directly below. Keep clear of all obstructions.”***

Inspection

The state or local gas inspector of the side-wall horizontally-vented gas-fueled equipment shall not approve the installation unless, upon inspection, the inspector observes carbon-monoxide detectors and signage installed in accordance with the provisions of *248 CMR 5.08(2)(a) 1 through 4*.

Exemptions

The following equipment is exempt from *248 CMR 5.08(2)(a)1 through 4*:

1. The equipment listed in Chapter 10 entitled “Equipment Not Required To Be Vented” in the most current edition of *NFPA 54* as adopted by the Board; and
2. Product Approved side-wall horizontally-vented gas-fueled equipment installed in a room or structure separate from the dwelling, building, or structure used in whole or in part for residential purposes.

Manufacturer Requirements - Gas Equipment Venting System Provided

When the manufacturer of Product Approved side-wall horizontally-vented gas-fueled equipment provides a venting system design or venting system components with the equipment, the instructions provided by the manufacturer for installation of the equipment and the venting system shall include::

1. Detailed instructions for the installation of the venting-system design or the venting-system components
2. A complete parts list for the venting-system design or venting system.

Manufacturer Requirements - Gas Equipment Venting System Not Provided

When the manufacturer of a Product Approved side-wall horizontally-vented gas-fueled equipment does not provide the parts for venting the flue gases, but identifies “special venting systems,” the following requirements shall be satisfied by the manufacturer:

1. The referenced “special venting system” instructions shall be included with the appliance or equipment installation instructions.
2. The “special venting systems” shall be Product Approved by the Board, and the instructions for that system shall include a parts list and detailed installation instructions.

A copy of all installation instructions for all Product Approved side-wall horizontally-vented gas-fueled equipment, all venting instructions, all parts lists for venting instructions, and/or all venting-design instructions shall remain with the appliance or equipment at the completion of the installation.

VENTING INSTALLATION

WARNING

Breathing Hazard - Carbon Monoxide Gas



- Install vent system in accordance with codes.
- Do not operate water heater if flood damaged.
- Install water heater in accordance with the instruction manual.
- Do not operate if soot buildup is present.
- Do not obstruct water heater air intake(s) with insulating jacket or blanket.
- Do not place chemical vapor emitting products near water heater.
- Install gas and carbon monoxide detectors for additional safety.
- Never operate the heater unless it is vented to the outdoors and has adequate air supply to avoid risks of improper operation, fire, explosion or asphyxiation.
- Analyze the entire vent system to make sure that condensate will not become trapped in a section of vent pipe and therefore reduce the open cross sectional area of the vent.

Breathing carbon monoxide can cause brain damage or death. Always read and understand instruction manual.

Never operate the water heater unless it is vented to outdoors. The instructions in this section of the manual must be followed to avoid choked combustion or recirculation of flue gases. Such conditions cause sooting of the combustion chamber, burners, and flue tubes, and creates a risk of asphyxiation.

GENERAL VENTING INFORMATION

The water heaters covered in this manual are Category IV appliances and may be installed in either a Power Vent or Direct Vent configuration.

Approved Materials

Approved vent and intake-air pipe materials that may be used in the United States:

PVC pipe materials:

- DWV ASTM-D2665 or CSA B181.2
- Schedule 40, 80, 120 ASTM-D1785 or CSA B137.3
- SDR Series ASTM-2241 or CSA B137.33

CPVC pipe materials:

- CPVC 41 ASTM-D2846 or CSA B137.6
- Schedule 40, 80 ASTM-F441 or CSA B137.6
- SDR Series ASTM-F442

Polypropylene (page 39)

- M & G Duravent PolyPro vent system
- Centrotherm InnoFlue vent system (includes flex)

AL29-4C Stainless Steel

- HeatFab Saf-T Vent
- Duravent FasNSeal

Approved vent pipe materials that must be used in Canada:

- ULC S636 PVC / CPVC
- ULC S636 Polypropylene
- AL29-4C Stainless Steel

Approved intake-air pipe materials that must be used in Canada:

PVC pipe materials:

- DWV ASTM-D2665 or CSA B181.2
- Schedule 40, 80, 120 ASTM-D1785 or CSA B137.3
- SDR Series ASTM-D2241 or CSA B137.3

CPVC pipe materials:

- SDR Series ASTM-D2241 or CSA B137.3
- Schedule 40, 80 ASTM-F441 or CSA B137.6
- SDR Series ASTM-F442

Polypropylene

- M & G Duravent PolyPro vent system
- Centrotherm InnoFlue vent system (includes flex)

AL29-4C Stainless Steel

- HeatFab Saf-T Vent
- Duravent FasNSeal

Where applicable, the installation of the venting system should be done in accordance with the venting system manufacturer's instructions.

Note: The use of cellular core PVC (ASTM F891), cellular core CPVC, or Radel® (polyphenolsulfone) in non-metallic venting systems is prohibited. Covering non-metallic vent pipe and fittings with thermal insulation is prohibited.

CATEGORY IV APPLIANCES

Category IV appliances operate with a positive vent (exhaust) static pressure and with vent-gas temperatures low enough to produce condensate in the vent piping.

Power Vent Configurations

Power Vent configurations derive all combustion air from the room where they are installed and discharge all flue gases to the outdoor atmosphere through a sealed vent (exhaust) pipe. Power vent configurations have one vent pipe connected to the water heater which can be terminated in a vertical or horizontal arrangement. See *Figure 56* and *Figure 57* (page 46).

Direct Vent Configurations

Direct Vent configurations derive all combustion air directly from the outdoor atmosphere through a sealed intake-air pipe and discharge all flue gases to the outdoor atmosphere through a sealed vent (exhaust) pipe. Direct Vent configurations have two pipes connected to the water heater, one vent pipe and one intake-air pipe. Direct Vent configurations can be terminated in one of seven different arrangements. See *Figure 58* through *Figure 64* (page 46).

General Venting Instructions

These instructions must be followed on all installations.

1. **Do not** install the water heater in a Power Vent configuration unless there is adequate supply of fresh air. See **Air Requirements** (page 25). If the installation space does not provide an adequate supply of fresh air the water heater must be installed in a Direct Vent configuration.
2. If the water heater is to be installed in a beauty shop, barber shop, cleaning establishment, a laundry with dry cleaning equipment

or any space with contaminated air it is imperative that the water heater(s) be installed in a Direct Vent configuration so that all air for combustion is derived from the outdoor atmosphere.

3. The vent and intake-air piping must terminate outdoors.
4. The minimum clearance from combustibles for the vent (exhaust) and intake-air piping shall be 0 inches. Vent piping passing through a combustible wall or ceiling must be a continuous run (no joints).
5. The water heater must be protected from freezing down-drafts during shutdown periods.
6. The vent (exhaust) pipe must not be combined or connected to any other appliance's vent system or chimney.
7. The intake-air pipe must not be combined or connected to any other appliance's intake-air piping.
8. Locate the water heater where the vent (exhaust) and intake-air piping will remain within the maximum equivalent lengths allowed. See (page 31).
9. Do not install the vent or intake-air piping in a manner that will allow water to be trapped in the piping.
10. The vent (exhaust) and intake-air piping must be pitched at a minimum of 2% grade back to the water heater (to allow drainage of condensate).
11. Do not anchor the vent or intake-air pipe directly to framed walls, floors or ceilings unless rubber isolation pipe hangers are used to prevent vibration noise from being transmitted.
12. Use only approved vent/intake-air pipe sizes and materials. See (page 31).
13. Use only factory supplied vent and intake-air, concentric or low profile terminations. See (page 31).
14. Do not locate the vent (exhaust) or intake-air terminations where they would be objectionable due to noise at the termination(s). This includes locations close to or across from windows and doors.
15. Direct venting into dead air spaces such as alleys, atriums, and inside corners can cause recirculation of flue gases. Recirculation of flue gases will cause sooting, premature failure of the heat exchanger and icing of the combustion air intake during severe cold weather. To prevent the recirculation of flue gases, maintain as much distance as possible between the intake-air and vent terminations.
16. Do not locate the vent termination over public walkways or a public area where condensate or vapor can cause a nuisance or ice hazard.
17. Ensure that the screens in the factory supplied terminations are securely installed to prevent blockage in the vent system.
18. Stress levels in pipe/fittings can be significantly increased by improper installation. If rigid pipe clamps are used to hold the pipe in place, or if the pipe cannot move freely through a wall penetration, the pipe may be stressed, or high thermal stresses may be formed when the pipe heats up and expands. Install accordingly to minimize such stresses.
19. Carefully read the and then proceed to the *Venting Installation Sequence* (page 35).

VENTING REQUIREMENTS

Field Supplied Fittings

Field-supplied fittings should be equivalent to the piping material being installed. Field-installed/supplied fittings will add equivalent length to the vent or intake-air piping as indicated below. All field-supplied/installed fittings and piping must be factored into the equivalent length calculations.

- 90° elbows (short or long radius) are equivalent to 5 linear feet (152 cm) of pipe.
- 45° elbows (short or long radius) are equivalent to 2.5 linear feet (76 cm) of pipe.

Note: See *Table 16* (page 40) and *Table 17* (page 40) for equivalent linear pipe length of AL29-4C® 45° and 90° elbows.

Primer and Cement

Tetrahydrofuran (THF) primer should be used to prepare the surfaces of pipe and fittings for solvent welding. If CPVC pipe and fittings are used, then the proper cement must be used for all joints, including joining the pipe to the factory provided terminations (PVC material). PVC Materials should use ASTM D-2564 Grade Cement; CPVC Materials should use ASTM F-493 Grade Cement.

Pipe Size Requirements

The water heaters covered in this manual are tested and certified to use exhaust vent and intake air pipe diameters of 2", 3", 4", and 6". See *Table 7*, *Table 8*, and *Table 9* (page 32) for correct pipe diameter, lengths, and amount of 90° and 45° bends.

Note: See *Table 16* (page 40) and *Table 17* (page 40) for equivalent linear pipe length of AL29-4C® 45° and 90° elbows.

There is no minimum equivalent length requirement for the intake air pipe.

The minimum equivalent length requirement for the exhaust pipe is 7 feet for all models.

Factory Supplied Fittings

The 119 gallon water heater ships with two (2) factory supplied 4 inch terminations (PVC 45° elbows with debris screen). If 6 inch intake-air or vent pipe is installed, factory supplied 6 inch terminations must be used (PN: 100111626).

The 60 gallon and 100 gallon water heaters ship with two factory supplied 3 inch terminations (PVC 45 deg elbows with debris screen). Factory supplied vent and intake-air terminations or concentric and low profile terminations must be used. If 2 or 4 inch intake-air or vent pipe is installed, factory supplied terminations must be installed. (PN: 100386033 for 2 inch and 100110909 for 4 inch). Factory supplied terminations and installed fittings (exhaust elbow and intake-air connection) add zero equivalent length to the vent and intake-air piping.

Note: Three-inch vent and/or intake pipe as well as 3 inch terminations previously used on older 300 and 400 models must be replaced with four-inch or six-inch pipe and four-inch or six-inch terminations depending on installed length.

Elbow Qty. (Model BTUs)	Maximum Feet (Meters)		
	2" Pipe	3" Pipe	4" Pipe
One (1) (all models)	70 (21.3)	95 (28.9)	145 (44.1)
Two (2) (all models)	65 (19.8)	90 (27.4)	140 (42.6)
Three (3) (all models)	60 (18.2)	85 (25.9)	135 (41.1)
Four (4) (all models)	55 (16.7)	80 (24.3)	130 (39.6)
Five (5) (all models)	N/A	N/A	125 (38.1)
Six (6) (all models)	N/A	N/A	120 (36.5)

Elbow Qty. (Model BTUs)	Maximum Feet (Meters)		
	2" Pipe	3" Pipe	4" Pipe
One (1) (150k BTU models)	45 (13.71)	145 (44.20)	195 (59.44)
One (1) (199k BTU models)	35 (10.67)	145 (44.20)	195 (59.44)
One (1) (250k BTU models)	15 (4.57)	145 (44.20)	195 (59.44)
Two (2) (150k BTU models)	40 (12.19)	140 (42.67)	190 (57.91)
Two (2) (199k BTU models)	30 (9.14)	140 (42.67)	190 (57.91)
Two (2) (250k BTU models)	10 (3.05)	140 (42.67)	190 (57.91)
Three (3) (150k BTU models)	35 (10.67)	135 (41.15)	185 (56.39)
Three (3) (199k BTU models)	25 (7.62)	135 (41.15)	185 (56.39)
Three (3) (250k BTU models)	NA	135 (41.15)	185 (56.39)
Four (4) (150k BTU models)	30 (9.14)	130 (39.62)	180 (54.86)
Four (4) (199k BTU models)	20 (6.10)	130 (39.62)	180 (54.86)
Four (4) (250k BTU models)	NA	130 (39.62)	180 (54.86)
Five (5) (150k BTU models)	NA	NA	175 (53.34)
Five (5) (199k BTU models)	NA	NA	175 (53.34)
Five (5) (250k BTU models)	NA	NA	175 (53.34)
Six (6) (150k BTU models)	NA	NA	170 (51.82)
Six (6) (199k BTU models)	NA	NA	170 (51.82)
Six (6) (250k BTU models)	NA	NA	170 (51.82)

Elbow Qty. (Model BTU)	Maximum Feet (Meters)	
	4" Pipe	6" Pipe
One (1) (all models)	95 (28.9)	145 (44.1)
Two (2) (all models)	90 (27.4)	140 (42.6)
Three (3) (all models)	85 (25.9)	135 (41.1)
Four (4) (all models)	80 (24.3)	130 (39.6)
Five (5) (all models)	75 (22.8)	125 (38.1)
Six (6) (all models)	70 (21.3)	120 (36.5)

INTAKE AIR CONNECTION

The water heaters covered in this manual are factory equipped with a unique Combustion Blower and intake-air connection Tee fitting. The Tee is a 3" x 3" x 1/2" fitting. The intake-air connection Tee fitting has a hose barb installed in the 1/2 inch branch to connect the Blocked Intake Air switch sensing tube.

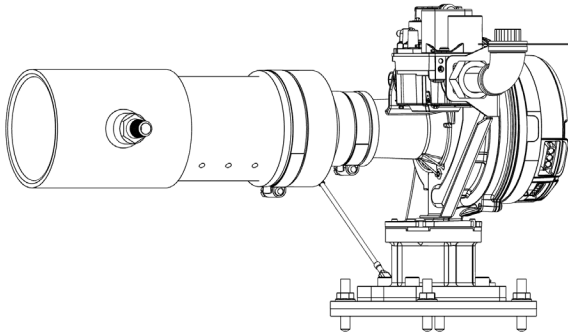

Figure 22. Intake Air Connection (60 Gallon)

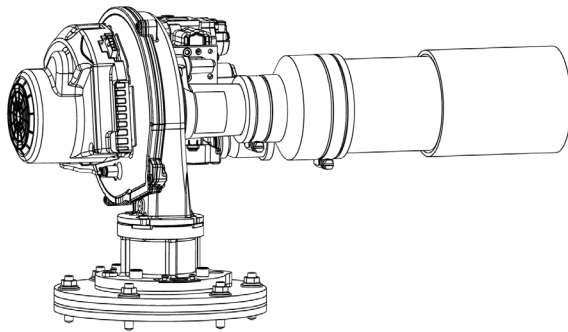

Figure 23. Intake Air Connection (100 Gallon)

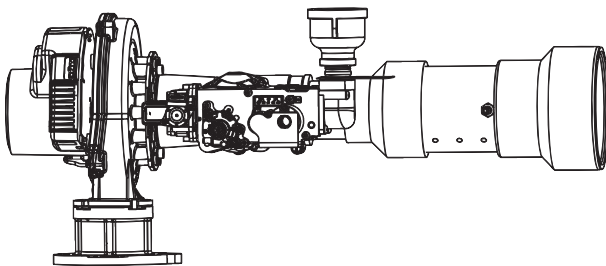

Figure 24. Intake Air Connection (119 Gallon)

Ensure that the hose barb installed in the Tee fitting IS NOT facing down towards the ground (180° - 6 o'clock position) before venting installation begins. The barb fitting must be angled between 90° and no more than 130° as shown in *Figure 25* (page 33). If the barb fitting is facing down, residual condensate that occasionally forms in the intake-air pipe can drain into the Blocked Intake Air switch through the attached sensing tube and damage the switch. This condition can also lead to Blocked Intake Air fault conditions and associated control system lockouts.

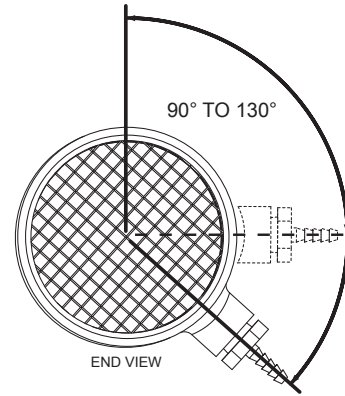

Figure 25. Intake Air Connection Hose Barb Angle Range for Proper Operation

The intake-air Tee fitting is factory-installed with the 1/2 inch branch and hose barb angled to the right at approximately 130° when viewed from the end. See *Figure 25*. The Tee fitting's 1/2 inch branch and hose barb must not be angled any lower (towards the ground) than this factory specification. Angling higher, up to a 90° position, will not adversely affect operation and is acceptable.

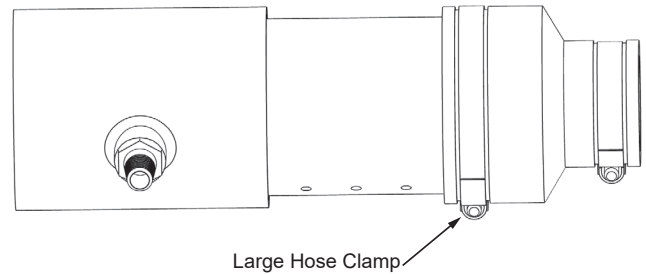

Figure 26. Intake Air Tee Fitting - Side View

Inspect/ Adjust Intake Air Tee Fitting

Inspect the angle of the tee fitting's 1/2 inch branch and hose barb while viewing from the end of the tee. See *Figure 25*. If the angle of the tee fitting 1/2 inch branch and hose barb is lower than shown, adjustment will be necessary. To adjust the intake-air tee fitting angle, follow the steps listed below.

1. Ensure that the water heater is turned off at the on/off switch on the front of the water heater.
2. Disconnect the blocked intake-air switch sensing tube. See *Figure 27* for the location.
3. Loosen the large hose clamp on the Fernco coupling that connects the intake-air connection pipe to the combustion blower. See *Figure 26* (page 33).
4. Adjust the angle of the tee fitting so that the 1/2 inch branch and hose barb are at the proper angle as shown in *Figure 25*.
5. Re-tighten the large hose clamp on the combustion blower intake-air Fernco coupling.

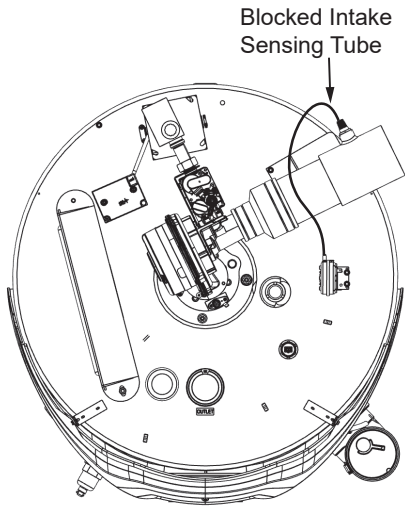

Figure 27. Blocked Intake Air Switch Sensing Tube

Required Terminations for Six-Inch Intake Air or Vent Pipe

When a six-inch intake-air or vent pipe is installed using standard terminations, factory-supplied six-inch terminations must be used. Contact Technical Support for assistance in ordering six-inch termination(s). See the contact information label on the water heater. See **Optional Terminations** (page 19) for more information.

Accessory Inlet Diverter Installation

Kit Part Numbers:

- 60/100 gallon: 100397866
- 119 gallon: 100397867

The intake-air Tee fitting is installed with the 1/2 inch branch and hose barb angled to the right at 90° when viewed from the end. See **Figure 28**.

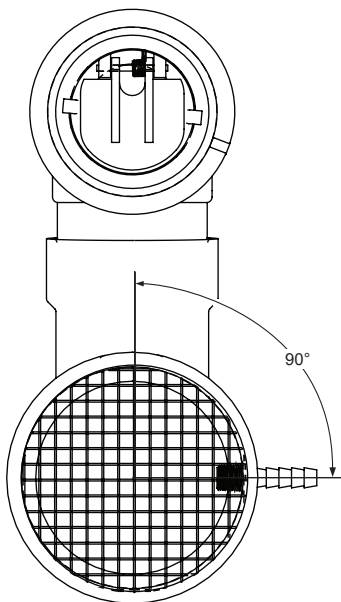

Figure 28. Intake Air Connection Hose Barb Angle for Proper Operation - End View

Inlet Diverter Assembly Installation

To install the intake-air tee fitting angle, follow the steps listed below.

1. Ensure that the water heater is turned off at the on/off switch on the front of the water heater.
2. Disconnect the blocked intake-air switch sensing tube. See **Figure 30** for the location.
3. Loosen the large hose clamp on the Fernco coupling that connects the intake-air connection pipe to the combustion blower. See **Figure 29**.
4. Remove the factory installed inlet.
5. Install the inlet diverter assembly.
6. Adjust the angle of the tee fitting so that the 1/2 inch branch and hose barb are at the proper angle as shown in **Figure 28**.
7. Re-tighten the large hose clamp on the combustion blower intake-air Fernco coupling.
8. Reconnect the block intake-air switch sensing tube.
9. The diverter assembly should be glued in place once the orientation has been determined.

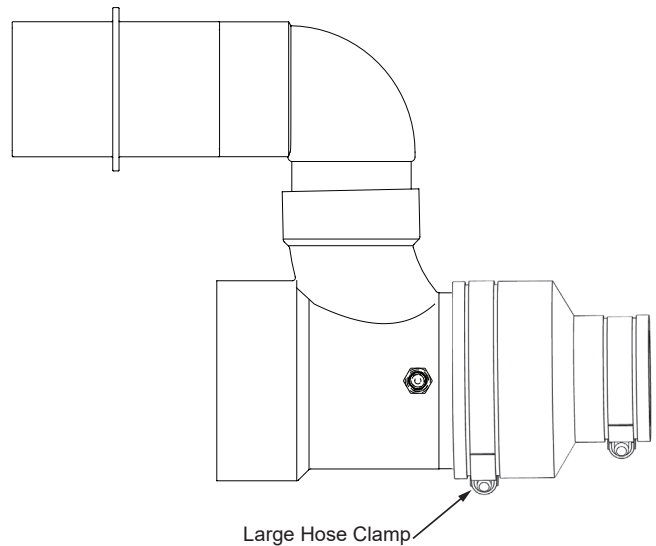

Figure 29. Intake Air Tee Fitting - Side View

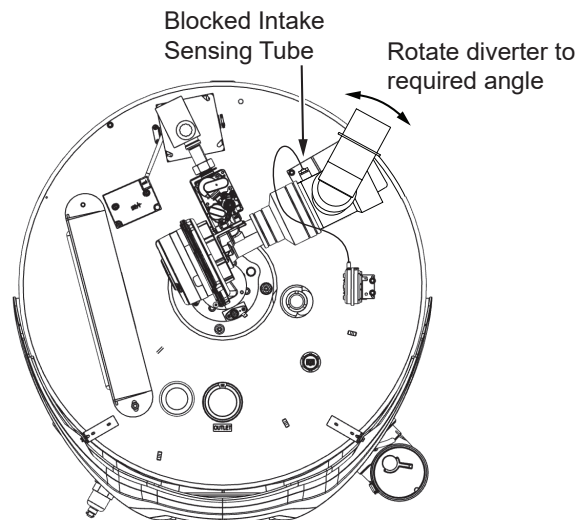

Figure 30. Diverter Assembly Rotation

VENTING INSTALLATION SEQUENCE

1. Read *General Venting Instructions* (page 30) and (page 31) before proceeding. These instructions and requirements must be followed on all installations.
2. Determine whether the water heater will be installed in a power-vent or direct-vent configuration and which vent system arrangement will be used for the installation. See *Venting Arrangements* (page 46).
3. Proceed to the applicable installation instructions:
 - *Power Vent Installation* (page 35) or
 - *Direct Vent Installation* (page 35).

POWER VENT INSTALLATION

1. Read *General Venting Instructions* (page 30) and (page 31) before proceeding. These instructions and requirements must be followed in addition to the instructions below that are specific for power vent configurations.
2. Determine which termination arrangement will be used for the installation: vertical or horizontal termination. See *Figure 50* and *Figure 51* (page 44).
3. Determine the vent pipe size for the installation. See (page 31).
4. Plan the layout of the vent piping backwards from the termination point outdoors to the water heater. Layout the vent piping to use a minimum of pipe and elbows.
5. Install the termination first. If the vent piping will terminate vertically through a roof, see *Vertical Termination Installation* (page 36).

If the vent piping will terminate horizontally through a sidewall, see *Sidewall Termination Installation* (page 38).

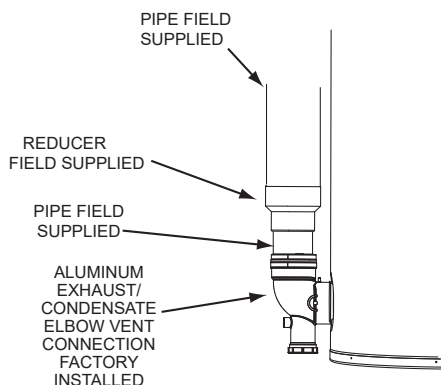

Figure 31. Vent Exhaust Connection

6. When installation of the termination is complete, install necessary piping and fittings to route the vent piping back to the water heater.
7. The vent pipe must be supported properly to avoid bending or failure. The water heater manufacturer recommends that the vent pipe be supported every 5 feet (152 cm) of vertical run and every 3 ft (91 cm) of horizontal run.
8. Do not install the vent piping in a manner that will allow water to be trapped in the piping.
9. All vent (exhaust) pipes must be pitched a minimum of 1/4 in (7 mm) per foot back to the water heater (to allow drainage of condensate).
10. 60/100 gallon - If installing three-inch vent pipe, connect the vent pipe to the exhaust elbow on the water heater. If installing two- or four-inch pipe, transition to three-inch pipe at the exhaust elbow on the water heater. The field-installed three-inch pipe between

the elbow and the reducer coupling should be 18 in (45 cm) or less in length.

11. 119 gallon - If installing four-inch vent pipe, connect the vent pipe to the exhaust elbow on the water heater. If installing six-inch pipe, transition to four-inch pipe at the exhaust elbow on the water heater. The field-installed four-inch pipe between the exhaust elbow and the 6" x 4" reducer coupling should be 18 in (45 cm) or less in length.

DIRECT VENT INSTALLATION

1. Read *General Venting Instructions* (page 30) and (page 31) before proceeding. These instructions and requirements must be followed in addition to the instructions below that are specific for direct-vent configurations.
2. Determine which direct-vent arrangement will be used for the installation. There are several direct-vent arrangement options *Figure 50* (page 44) and *Figure 51* (page 44).
3. Determine the vent and intake-air pipe sizes to be used for the installation. See (page 31).
4. Plan the layout of the vent and intake-air piping backwards from the termination point outdoors to the water heater. Layout the vent and intake-air piping to use a minimum of pipe and elbows.
5. Install the terminations first.
 - If standard terminations are being used, and the intake-air or vent piping will terminate vertically through a roof, see *Vertical Termination Installation* (page 36).
 - If standard terminations are being used, and the intake-air or vent piping will terminate horizontally through a sidewall, see *Sidewall Termination Installation* (page 38).
 - If a low-profile termination will be used, see *Table 18* (page 45).
6. When installation of the termination(s) is complete, install the necessary piping and fittings to route the intake-air and vent piping back to the water heater. The intake-air and vent piping must be supported properly to avoid bending or failure. The water heater manufacturer recommends that the vent and intake-air piping be supported every 5 ft (152 cm) of vertical run and every 3 ft (91 cm) of horizontal run.
7. Do not install the vent or intake-air piping in a manner that will allow water to be trapped in the piping.
8. A field-supplied condensate tee fitting and drain hose must be installed in the intake-air piping near the water heater in colder climates with heavy snow accumulations and in areas that regularly experience high humidity. The drain hose must be routed to an adequate floor drain separate from any other condensate drain hoses. See *Figure 32* (page 36).

Note: Snow being pulled into the intake-air piping and then melting can lead to excessive amounts of water accumulation and damage to the water heater components. Warm, humid outdoor air can lead to excessive condensation inside the intake-air piping and may also damage water heater components.
9. The intake-air and vent (exhaust) piping must be pitched a minimum of 1/4 in (7 mm) per foot back to the water heater (to allow drainage of condensate).
10. 10. 119 gallon - If installing four-inch vent pipe, connect the vent pipe to the exhaust elbow on the water heater. If installing six-inch vent pipe, transition to four-inch pipe at the exhaust elbow on the water heater. The field-installed four-inch pipe between the exhaust elbow and the 6" x 4" reducer coupling should be 18 in (45 cm) or less in length.

11. 60/100 gallon - If installing three-inch vent pipe, connect the vent pipe to the exhaust elbow on the water heater. If installing two- or four-inch vent pipe, transition to three-inch pipe at the exhaust elbow on the water heater. The field-installed three-inch pipe between the exhaust elbow and the reducer coupling should be 18 in (45 cm) or less in length

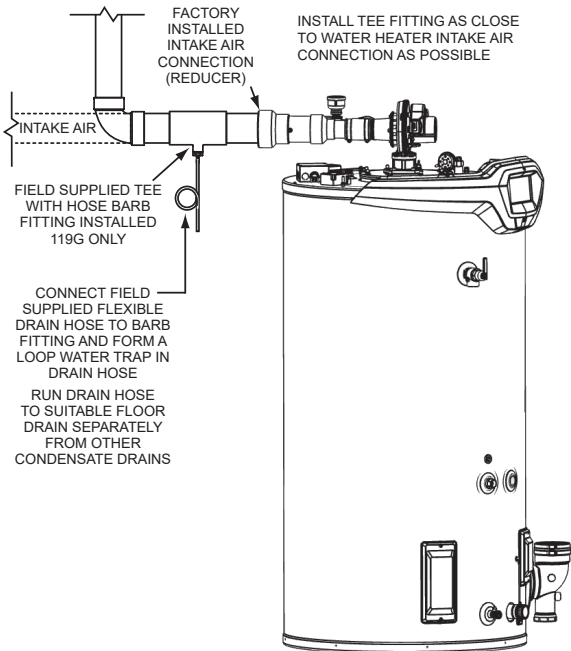

Figure 32. Intake Air Condensate Tee Installation

12. Ensure that the intake-air screen on the intake-air connection is removed before connecting the intake-air pipe to the water heater. See Figure 33.

WARNING	
Breathing Hazard - Carbon Monoxide Gas	
	<ul style="list-style-type: none"> • Do not obstruct water heater air intake. • Gas and carbon monoxide detectors are available. • Install water heater in accordance with the instruction manual and applicable codes.
<p>Breathing carbon monoxide can cause brain damage or death. Always read and understand instruction manual.</p>	

Note: Do not leave the screen inside the intake-air connection in direct-vent installations. Once the intake-air pipe is installed, the screen will be hidden from view and may become clogged with debris over time. This will cause improper combustion.

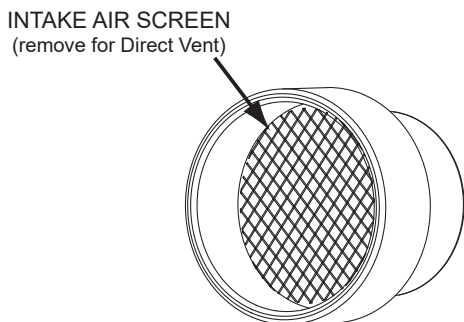

Figure 33. Intake Air Screen

13. On 119 gallon models, if installing four-inch intake-air pipe, connect the intake-air pipe to the intake-air connection on the water heater. On 60/100 gallon models, if installing three-inch intake-air pipe, connect the intake-air pipe to the intake-air connection on the water heater.
14. On 119 gallon models, if installing six-inch intake-air pipe, transition to four-inch pipe at the intake-air connection on the water heater. The field-installed four-inch pipe between the intake-air connection and the 6" x 4" reducer coupling should be 18 in (45 cm) or less in length. On 60/100 gallon, if installing two- or four-inch intake-air pipe, transition to three-inch pipe at the intake-air connection on the water heater. The field-installed three-inch pipe between the intake-air connection and the reducer coupling should be 18 in (45 cm) or less in length.

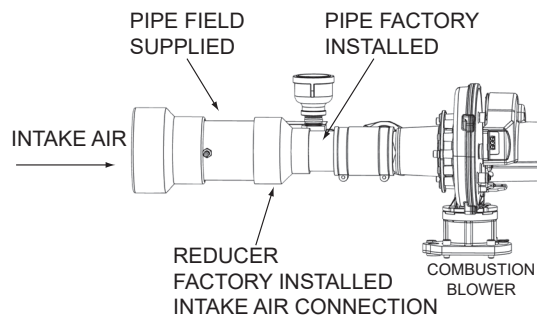

Figure 34. Intake-Air Connection (119-Gallon Model)

Direct Vent Air Intake Moisture Protection

The air intake piping in a direct-vent system will normally not have any moisture accumulation in it. However, in certain cases, moisture can build up and needs to be drained. Typical situations include, but are not limited to the following:

- Cold outdoor temperature, particularly if the air inlet is short
- High outdoor humidity
- Heater being used mostly for space heating
- Air inlet pipe has vertical rise near the heater

Installations with any of these conditions are required to provide a moisture drain with a trap that flows to a waste drain. **Figure 32** (page 36) and **Figure 50** (page 44) through **Figure 56** (page 46). A horizontal section of the air-inlet pipe near the heater should include a 4" x 4" x 1/2" (119 gallon) and 3" x 3" x 1/2" (60/100 gallon) tee and a hose barb fitting to drain the water. The tee should be as close to the heater as is practical. The drain tubing in any installation should have a loop trap and flow to an appropriate waste drain. The air-intake drain line must be entirely separate from the exhaust vent outlet condensate drain line.

VERTICAL TERMINATION INSTALLATION

1. Determine the location for the termination(s).
2. If installing only the vent (exhaust) piping in a power-vent configuration vertically through the roof, ensure that all exterior vertical clearance requirements shown in **Figure 35** and **Figure 36** (page 37) are being maintained. These clearances and those cited by local and national codes must be maintained.

Note: On flat roof installations, the vent termination must be a minimum of 24 in (60 cm) above any parapet, vertical wall, or structure within 10 ft (3 m) horizontally. See **Figure 36**.

3. If installing both intake-air and vent piping in a direct-vent configuration vertically through the roof, ensure that all exterior

vertical clearance requirements shown in *Figure 35*, *Figure 36* (page 37), and *Figure 37* (page 38) are being maintained. These clearances and those cited by local and national codes must be maintained.

Note: On flat roof installations, the intake-air and the vent terminations must be a minimum of 24 in (60 cm) above any parapet, vertical wall or structure within 10 ft (3 m) horizontally. See *Figure 36*.

4. If installing only vent piping in a power-vent configuration vertically through the roof, the following instructions must be followed:
 - A. The vent termination must be oriented facing downward as shown in *Figure 35* and *Figure 36*.
 - B. The bottom edge of the vent termination must be a minimum of 12 in (30 cm), 18 in (45 cm) in Canada, above the average or expected snow level as shown in *Figure 35*.
5. If installing both intake-air and vent piping in a direct vent configuration vertically through the roof, the following instructions must be followed:
 - A. The intake-air and vent pipes must penetrate the same side of the roof as shown in *Figure 37* (page 38).
 - B. The intake-air and vent terminations must be oriented facing downward and in the same direction as shown in *Figure 37* (page 38).
 - C. The intake-air and vent terminations must have a minimum separation of 24 in (61 cm) measured on the center line, as shown in *Figure 37*. In colder climates, this separation should increase to at least 48 in (122 cm).
 - D. The bottom edge of the intake-air and vent terminations must be a minimum of 12 in (30 cm), 18 in (45 cm) in Canada, above the average or expected snow level as shown in *Figure 35* below.

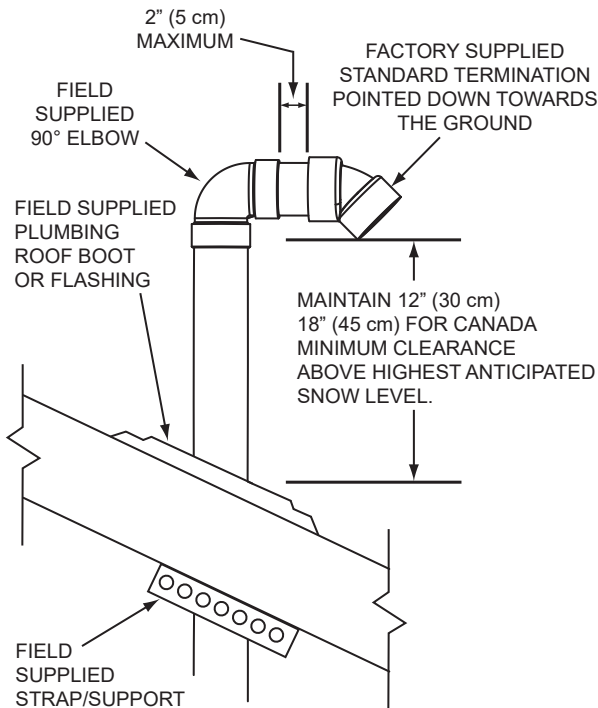

Figure 35. Vertical Termination(s) Installation

grouped together in close proximity 0 in (0 cm) / touching. Intake-air terminations can also be grouped together in close proximity 0 in (0 cm) / touching.

The distance between the closest vent and intake-air terminations must be a minimum of 24 in (61 cm) as shown in *Figure 37* (page 38). In colder climates, this separation should be increased to at least 48 in (122 cm).

7. Cut a 5 in (13 cm) diameter hole for four-inch pipe or an 7 in (18 cm) diameter hole for six-inch pipe where the pipe(s) will pass through the roof

Note: Beware of concealed wiring and piping when cutting through the roof.

Pipe Size	Hole Size
2 in	3 in (7.6 cm)
3 in	4 in (10 cm)
4 in	5 in (12.7 cm)
6 in	7 in (17.7 cm)

8. Suspend the pipe(s) through center of hole using field-supplied metal strapping or equivalent support materials as shown in *Figure 35*.
9. Slide a roof boot or equivalent flashing over the pipe, secure the roof boot or equivalent flashing to the roof (see *Figure 31*), and seal around the flashing.
10. Install the factory-supplied intake-air and/or vent termination(s) using field-supplied pipe and one field-supplied 90° elbow as shown in *Figure 35*. The short section of pipe that connects between the field-supplied 90° elbow and the factory-supplied termination must not be excessive in length. The exposed portion of this pipe shall be no more than 2 in (5 cm). See *Figure 35*.

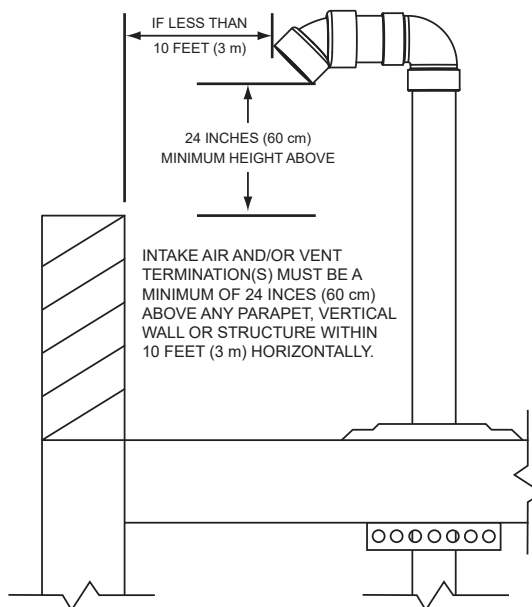

Figure 36. Vertical Termination(s) Flat Roof Parapet Clearance

6. When the intake-air and/or vent piping from multiple water heaters will terminate in the same location, the vent terminations can be

11. Return to *Power Vent Installation* (page 35) or *Direct Vent Installation* (page 35) to complete the installation of the intake-air and/or vent piping between the termination(s) and the water heater.

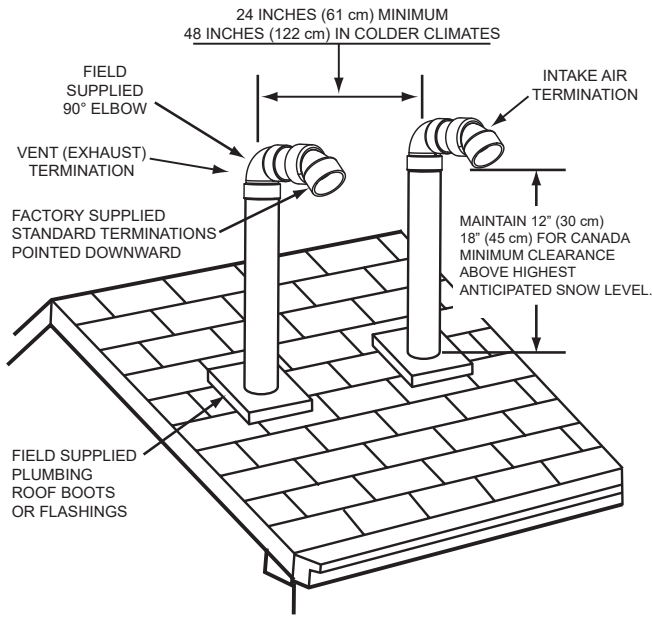

Figure 37. Vertical Termination - Direct Vent

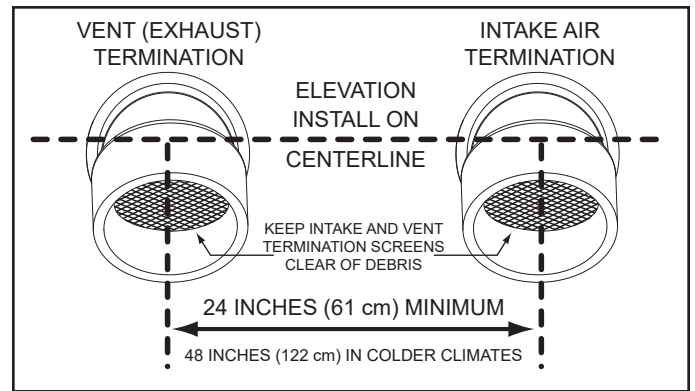

Figure 38. Sidewall Termination - Direct Vent

SIDEWALL TERMINATION INSTALLATION

1. Determine the location for the termination(s).
2. If installing both intake-air and vent piping in a direct-vent configuration through a sidewall, ensure that all exterior sidewall clearance requirements for the terminations shown in *Figure 66* (page 49), are being maintained. These clearances, and those cited by local and national codes, must be maintained.
3. If installing both intake-air and vent piping in a direct-vent configuration through a sidewall, ensure that all exterior sidewall clearance requirements for the terminations shown in *Figure 66* (page 49), for the vent and intake-air termination, are being maintained. These clearances, and those cited by local and national codes, must be maintained.
4. If installing both an intake-air and vent termination in a direct-vent configuration through a sidewall, there must be a minimum of 24 in (61 cm) separation, measured on a vertical center line, between the intake-air and vent terminations. See *Figure 38*.

Note: In colder climates, this separation should be increased to at least 48 in (122 cm) between the intake-air and vent termination or any other appliance vent that discharges moisture-laden air such as clothes dryers. This will reduce possibility of frost over from side winds blowing exhaust vapors to the intake-air termination and is recommended for Canadian installations.

5. If installing both intake-air and vent terminations in a Direct Vent configuration through a sidewall, the intake-air and vent terminations must be installed at the same elevation, measured on horizontal center line. See *Figure 38*.

6. When the intake-air and/or vent piping from multiple water heaters will terminate at the same location through a sidewall, the vent terminations can be grouped together in close proximity - 0 in (0 cm) / touching. The intake-air terminations can also be grouped together in close proximity - 0 in (0 cm) / touching.

However, the distance between the closest vent and intake-air terminations must be a minimum of 24 in (61 cm). In colder climates, this separation should be increased to at least 48 in (122 cm). See *Figure 38* (page 38).

7. Cut a hole where the pipe(s) will pass through the wall. See *Table 10* (page 37) for the size of the hole needed.

Note: Beware of concealed wiring and piping when cutting through the wall.
8. Refer to vent hole size table in previous page.
9. Vent Termination – exhaust gases of this water heater are less than 140°F (60 C°). In cold climates, water vapor in the exhaust gases will condense into a cloud of vapor where the vent exits the building. This vapor can gradually discolor exterior building surfaces. The vent termination should be located where this vapor cloud and potential discoloration are not a concern. Extending the exposed vent piping up to a maximum of 6 in (15.2 cm) from the wall helps vapor from being trapped along a building's face. To avoid this problem, the vent can also be terminated vertically through the roof, see *Vertical Termination Installation* (page 36).
10. Cement the intake-air and/or vent termination to the section(s) of pipe cut to length in the above step.
11. Slide the included metal wall plate(s) over the pipe(s) to stop against the intake-air and/or vent termination. Place some silicone caulking (field-supplied) on the back of the wall plate(s) to secure it to the wall.
12. Working from outside, slide the pipe and termination(s) assembled in the above steps through the wall. Ensure that the termination(s) is pointed down towards the ground. See *Figure 39*.

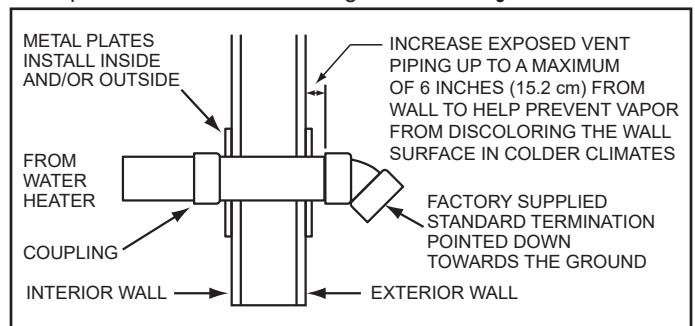

Figure 39. Sidewall Termination Installation

13. Place a bead of silicone caulking (field-supplied) around the gap between the installed pipe(s) and the wall. Apply enough to fill the gap between the pipe(s) and wall.
14. Press the wall plate flush against the outside wall.
15. Working from the inside, apply enough silicone caulking on the back of the interior wall plate(s) to hold it in place and slide the wall plate over the installed pipe(s).
16. Install a coupling to the end of the pipe(s) inside the building. Before the silicone caulking has time to completely set, go outside the building and ensure that the termination(s) is still pointing down towards the ground. See *Figure 39*.
17. Return to *Power Vent Installation* (page 35) or *Direct Vent Installation* (page 35) to complete the installation of the intake-air and/or vent piping between the termination(s) and the water heater.

Insulation should not be used on Polypropylene venting materials. The use of insulation will cause increased vent wall temperatures, which could result in vent pipe failure.

Use only the adapters and vent system listed in the tables below. **DO NOT** mix vent systems of different types or manufacturers. Failure to comply could result in severe personal injury, death, or substantial property damage.

Installations must comply with applicable national, state, and local codes. For Canadian installation, Polypropylene vent must be listed as a **ULC-S636** approved system. If Polypropylene vent is not required by your local code, you may use either PVC or CPVC pipes for your water heater, which allow non-metallic venting material installations.

Polypropylene vent systems do not use cement to connect the pipe and elbow sections, but use a push together gasket seal method. Do not attempt to connect Polypropylene with sealant cement. All vent connections **MUST** be secured by the vent manufacturer's joint connector. The installer must use a specific vent starter adapter at the flue connection. The adapter is supplied by the vent manufacturer to adapt to its vent system.

In order to be in full compliance with **UL-1738** or **ULC-S636** and to meet the requirements of the water heater manufacturer, you must use the metal joint-connector rings, available from the Polypropylene vent manufacturer, to stiffen the joints of four-inch and six-inch diameter pipes.

POLYPROPYLENE INSTALLATIONS (RIGID)

The water heaters covered by this manual have been approved to be installed with Polypropylene vent material as shown in *Table 11* and *Table 12*. The approved application of single wall, non-flexible, non-concentric Polypropylene vent material is offered by two specific manufacturers (Centrotherm ECO Systems and DuraVent Polypropylene). These listed products must be installed by following the vent manufacturer's instructions. See *Table 7*, *Table 8*, and *Table 9* (page 32) to determine the maximum pipe length and maximum number of elbows that can be used.

Table 11. M & G DuraVent PolyPro Vent system part numbers

Nominal Pipe Diameter	Flue Outlet Adapter	Adapter Connector	Ring Connector	90 Degree Elbow	Vent Material	Vent Terminal(s)
2"	2PPS-AD	PPS-PAC	2PPS-LB	2PPS-E90B	2PPS	2PPS-E45B for Exhaust; 2PPS-E45B for Intake (Direct Vent Only)
3"	3PPS-AD	PPS-PAC	3PPS-LB	3PPS-E90B	3PPS	3PPS-E45B for Exhaust; 3PPS-E45B for Intake (Direct Vent Only)
4"	4PPS-AD	PPS-PAC	4PPS-LB	4PPS-E90B	4PPS	4PPS-E45B for Exhaust; 4PPS-E45B for Intake (Direct Vent only)
6"	6PPS-06PVC-6PPF	PPS-PACL	6PPS-LBC	6PPS-E90	6PPS	6PPS-E45 for Exhaust; 6PPS-E45 for Intake (Direct Vent only)

Table 12. Centrotherm InnoFlue SW Vent system part numbers

Nominal Pipe Diameter	Flue Outlet Adapter	Adapter Connector	Ring Connector	90 Degree Elbow	Vent Material	Vent Terminal(s)
2"	ISAGL0202	IAFC02	IANS02	ISELL0287	ISVL02	ISELL0245UV for Exhaust; ISELL0245UV for Intake (Direct Vent only)
3"	ISAGL0303	IAFC03	IANS03	ISELL0387	ISVL03	ISELL0345UV for Exhaust; ISELL0345UV for Intake (Direct Vent only)
4"	ISAGL0404	IAFC04	IANS04	ISEL0487	ISVL04	ISELL0445UV for Exhaust; ISELL0445UV for Intake (Direct Vent only)
6"	ISAGL0606	IAFC06	IANS06	ISEL0687	Polypropylene	ISELL0645UV for Exhaust; ISELL0645UV for Intake (Direct Vent only)

FLEXIBLE POLYPROPYLENE

All previous notes about polypropylene venting installations apply to the flexible polypropylene.

For use of flex pipe, it is recommended to have the vent material in 32°F (0°C) or higher ambient space before bending at installation. No bends should be made greater than 45° and ONLY installed in

vertical or near vertical installations. When choosing flex pipe, make notation of appropriate sizing of flex to any existing B-vent material to ensure proper fit of pipe- i.e. if there exists 4" B-vent material then 2" or 3" flex would be appropriate for that installation. The approved flex pipe is intended ONLY for room-air or power-vent configuration and

is intended to be a replacement option for those who are replacing atmospheric or room-air systems.

The approved application of flexible polypropylene vent material is offered by one specific manufacturer (Centrotherm ECO Systems). These listed products must be installed by following the vent manufacturer's instructions. See **Table 15** to determine the maximum

equivalent flexible pipe length that can be used (including non-flexible polypropylene). The flexible polypropylene MAY only be used with the appropriate non-flexible polypropylene vent system (for Centrotherm Flexible Polypropylene, Centrotherm InnoFlue SW-**Table 12**).

For approved flexible polypropylene venting, refer to **Table 13** and **Table 14**.

Table 13. Centrotherm InnoFlue Flex Vent System Part Numbers (other components)	
Description	Part Number
Universal B-Vent Cap	IAUBVC
B-Vent Support Bracket	IABVSB

Table 14. Centrotherm InnoFlue Flex Vent System Part Numbers								
Nominal Pipe Diameter	Vent Length	SW to Flex Coupler	Flex to SW Coupler	Flex to Flex Coupler	B-Vent Kits	B-Vent Component Kits	Flex End Pipe	Base Supports
2"	IFVL02	IFSFC02	IFFSC02	IFFFC02	IFBK02	IFBKC02	IFEP02	ISBS02
3"	IFVL03	NA	IFFSC03	IFFFC03	IFBK03	IFBKC03	IFEP03	ISBS03
4"	IFVL04	NA	IFFSC04	IFFFC04	IFBK04	IFBKC04	IFEP04	ISBS04

Table 15. Centrotherm InnoFlue Polypropylene (Flex) Equivalent Length			
Model	Maximum Number of Feet (Meters)		
	2" Pipe	3" Pipe	4" Pipe
100/120 /145	45 (13.71)	100 (30.48)	150 (45.72)
150 /199 /250	---	70 (21.33)	200 (60.96)
251/300/400/500	---	---	100 (30.48)

AL29-4C® VENT INSTALLATIONS

(AL29-4C® is a registered trademark of Allegheny Technologies, Inc.)

The water heaters covered by this manual are approved to be installed with AL29-4C® stainless steel vent material using parts from the manufacturers listed in **Table 16** and **Table 17** below. These listed systems must be installed using the vent manufacturer's instructions including their listed clearances to combustible and noncombustible materials. See **Table 7** (page 32) for the maximum and minimum equivalent linear vent lengths and number of elbows that may be used. However, see **Table 16** and **Table 17** below to find the appropriate equivalent linear vent lengths for the AL29-4C® elbows.

Note: The equivalent lengths of the AL29-4C® elbows are different than those from smooth walled plastic vents. See **Table 16** and **Table 17** for the correct equivalent linear vent lengths.

Listed vent systems composed of AL29-4C® must not mix parts from the different manufacturers. The joints of these products are sealed by internal gaskets. Do not use any other type of sealant. When assembling these vent systems, follow the vent manufacturer's instructions for cleaning and lubricating the joints, if required. Each section must be locked together using the method supplied by the vent manufacturer.

The water heaters covered by this manual can be installed using the approved vent terminations shown in this manual. This means that, the installer must use the adapter listed in **Table 16** and **Table 17** and a short piece of PVC pipe to complete the end of the vent system with an approved termination. In Canada, the PVC pipe length must be listed to **ULC636**.

Table 16. HeatFab Saf-T Vent AL29-4C® Vent System Parts							
Dia.	Flue Outlet Adapter	*Straight Pipe (3' Section)	45° Elbow	Equivalent Linear Length, 45° Elbow	90° Elbow	Equivalent Linear length, 90° Elbow	Adapter to PVC
3"	9301 PVC	9307	9311	5 ft (178 cm)	9314	10 ft (305 cm)	9353CPVC
4"	9401 PVC	9407	9411	5 ft (178 cm)	9414	10 ft (305 cm)	9454CPVC
6"	9601 PVC	9607	9611	5 ft (178 cm)	9614	10 ft (305 cm)	9656CPVC

*Consult vent manufacturer's catalog for other available lengths.

Table 17. DuraVent FasNSeal AL29-4C® Vent System Parts							
Dia.	Flue Outlet Adapter	*Straight Pipe (3' Section)	45° Elbow	Equivalent Linear Length, 45° Elbow	90° elbow	Equivalent Linear Length, 90° Elbow	Adapter to PVC
3"	810005378	FSQL3603	FSELB4503	5 ft (178 cm)	FSELB9003	10 ft (305 cm)	810009530
4"	810005545	FSQL3604	FSELB4504	5 ft (178 cm)	FSELB9004	10 ft (305 cm)	810009529
6"	810005225	FSQL3606	FSELB4506	5 ft (178 cm)	FSELB9006	10 ft (305 cm)	810005572

*Consult vent manufacturer's catalog for other available lengths.

COMMON VENTING

The water heaters covered by this manual may be installed using a common horizontal direct vent kit. Contact Technical Support for assistance in ordering common vent kits. See the contact information label on the water heater.

CONCENTRIC TERMINATION INSTALLATION

Concentric terminations must be ordered separately.

- The 100k - 250k BTU/h models must use the four-inch concentric termination, Part Number: 100111100, for both three-inch and four-inch vent diameters or the two-inch terminal (100112869) for two-inch diameter pipe.
- The 251k-500k BTU/h models must use the six-inch concentric termination for both 4" & 6" vent diameters, Part Number: 100113124.

Contact Technical Support for assistance in ordering concentric terminations. See the contact information label on the water heater.

1. Determine the location for the termination.

Note: Roof termination is preferred since it is less susceptible to damage, has reduced risk of intake contaminants, and vent vapors are less visible.

2. When installing a concentric termination vertically through the roof, ensure that all exterior vertical clearance requirements for the concentric termination shown in *Figure 40* and *Figure 43* (page 42) are being maintained. These clearances and those cited by local and national codes must be maintained.

3. When installing a concentric termination vertically through a flat roof, the termination's vent cap must be a minimum of 10 ft (3 m) away from any parapet, vertical wall, or structure as shown in *Figure 40*.

Note: If this required distance to a parapet, vertical wall, or structure cannot be maintained, standard terminations must be used. See *Vertical Termination Installation* (page 36).

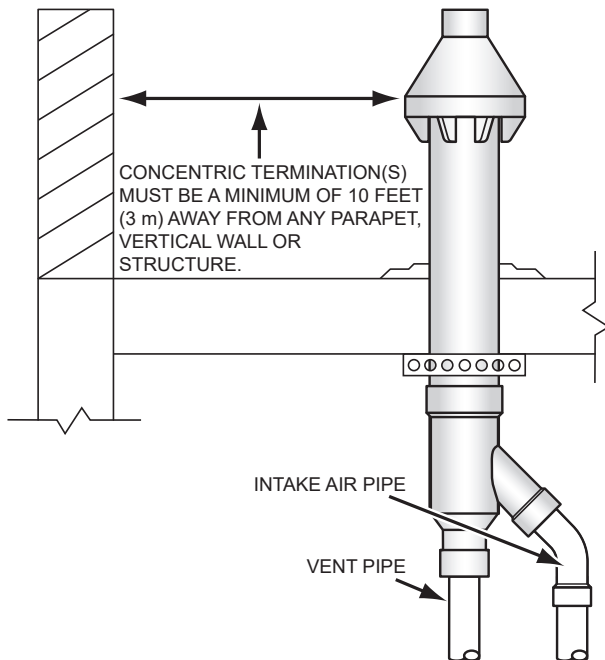

Figure 40. Concentric Termination - Flat Roof Parapet Clearance

4. When installing a concentric termination through a sidewall, ensure that all exterior sidewall clearance requirements for the termination shown in *Figure 66* (page 49) are being maintained. These clearances and those cited by local and national codes must be maintained.
5. When installing multiple concentric terminations vertically through a roof or horizontally through a sidewall, ensure that the required clearances between terminations and groupings of multiple

terminations are maintained. See *Multiple Concentric Termination Clearances* (page 42) for more information.

6. Cut a 7 in (18 cm) diameter hole for six-inch concentric terminations where they will pass through the wall or roof. Cut a 5 in (13 cm) diameter hole for the four-inch concentric terminal or a 3 in (7.6 cm) hole for the two-inch terminal, where the termination will pass through the wall or roof.

Note: Beware of concealed wiring and piping when cutting through the wall or roof.

7. When installing multiple concentric terminations vertically through the roof in the same location, the termination caps for all concentric terminations must be at the same height measured from ground. See *Multiple Concentric Termination Clearances* (page 42).

8. Determine if the concentric termination will need to be shortened to accommodate required clearances or to ensure that all vent caps are at the same height when installing multiple terminations vertically through the roof in the same location.

See *Figure 41* and *Figure 42* for the minimum lengths allowed for concentric termination.

Note: When shortening the length of the termination, carefully measure and cut the larger (intake-air) pipe first. Cut the same amount of pipe off of the smaller (vent) pipe.

Note: Lengthening of the Concentric Vent Termination is not permitted.

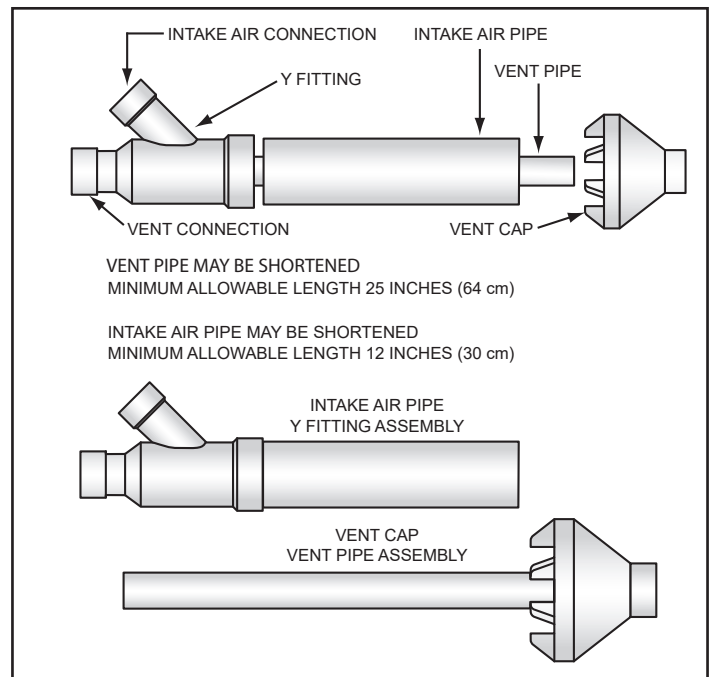

Figure 41. Concentric Termination Kit - 60/100 Gallon

9. Assemble and install the concentric termination. See *Figure 42*, *Figure 43*, and *Figure 44* for these instructions.

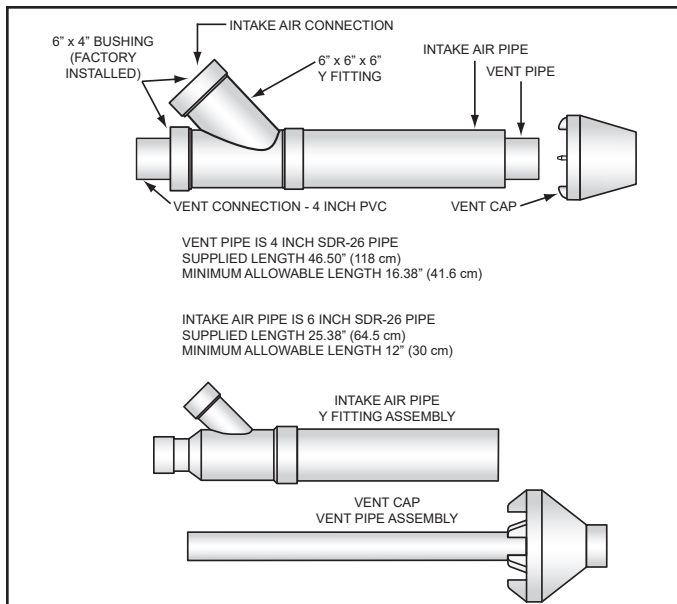

Figure 42. Concentric Termination Kit - 119 Gallon

10. Cement the Y fitting to the larger diameter intake-air pipe.
11. Slide the intake-air pipe and Y fitting assembly from inside the building through the hole cut for the termination in the roof or sidewall. Ensure no foreign materials, such as insulation, accumulate inside the assembly.
12. Secure the intake-air Y-fitting assembly using field-supplied metal strapping or equivalent support materials.
13. On installations installed through the roof, slide a field-supplied plumbing boot or roof flashing over the intake-air Y-fitting assembly and secure it to the roof.
14. Seal around the plumbing boot or roof flashing.
15. Cement the vent cap onto the vent pipe. Alternately a field-supplied stainless-steel screw can be used to secure the two components together when field disassembly is desired for cleaning. A pilot hole must be drilled for the screw to prevent damage/cracking of the vent cap and/or vent pipe.
16. Install the vent cap/vent pipe assembly into the intake-air Y-fitting assembly. Ensure that the small-diameter vent pipe is cemented and bottomed in the Y fitting.
17. Connect the intake-air and vent piping from the water heater to the six-inch concentric termination using field-supplied reducer couplings as needed. Cement all fittings and pipe in place. Use the appropriate method for connecting intake-air and vent piping to the terminations as follows:
 - For two-inch installations, connect the pipe directly to the two-inch termination.
 - For three-inch installations, connect the pipe directly to the three-inch termination. Do not mix different pipe and termination sizes.
 - For four-inch pipe installations, connect the piping to the concentric termination using field-supplied 4" x 3" reducer coupling and short sections of three-inch pipe 18 in (45 cm) or less.

Do not exceed the maximum equivalent vent length in **Table 7**, **Table 8**, and **Table 9** (page 32).

18. Return to **Direct Vent Installation** (page 35) to complete the installation of the intake-air and vent piping between the concentric termination and the water heater.

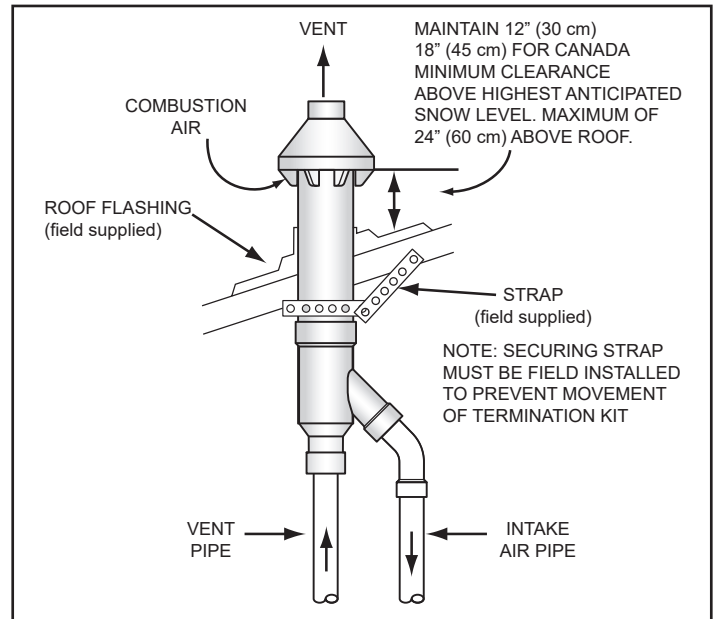

Figure 43. Concentric Termination - Vertical Installation

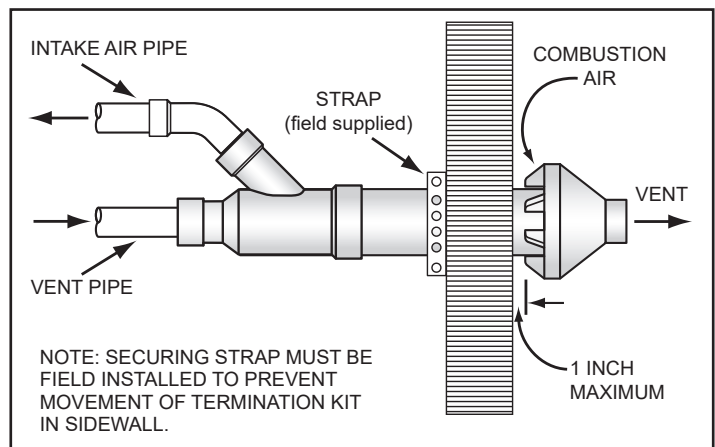

Figure 44. Concentric Termination - Sidewall Installation

Multiple Concentric Termination Clearances

When installing multiple concentric terminations vertically through a roof or horizontally through a sidewall, ensure that the required clearances (separation) between terminations are maintained. Ensure multiple terminations are arranged or grouped as required.

Note: These clearances must be maintained to prevent the recirculation of vent (exhaust) gases to the intake-air. Clearances are measured between the edges of the concentric termination caps.

When installing multiple concentric terminations through a roof or through a sidewall, the clearances shown in **Figure 45** (page 43) through **Figure 49** (page 43) must be maintained.

Close Proximity & Standard Clearance

1. The clearance between multiple termination caps must be 0 in (0 cm) / touching to a maximum of 2 in (5 cm), dimension A - *Figure 45*, when installing concentric terminations in close proximity. See *Figure 45* through *Figure 49*.
2. The clearance between multiple termination caps must be increased to a minimum of 24 in (61 cm), dimension B - *Figure 45*, when installation in close proximity (above) is not possible. This is the standard clearance.

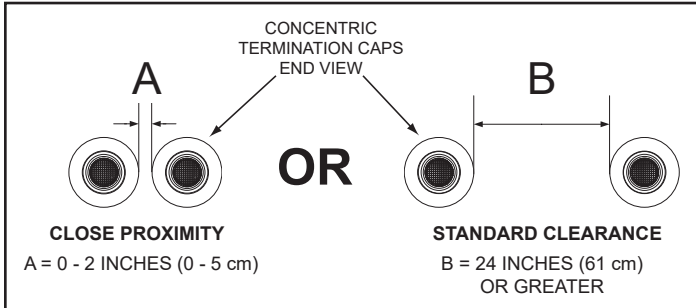

Figure 45. Two Concentric Terminations

Three Concentric Terminations

1. When installing three concentric terminations through a roof or through a sidewall, the third termination can be installed in close proximity as indicated by dimension A in *Figure 46*.
2. If close-proximity installation of the third termination is not possible, the third termination can be installed as indicated by dimension B in *Figure 46*.

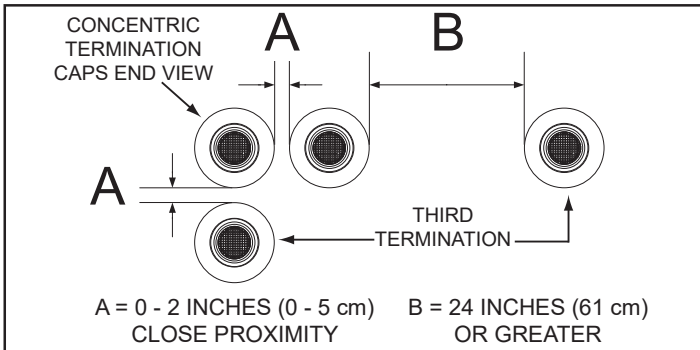

Figure 46. Three Concentric Terminations

Four Concentric Terminations

1. When installing four concentric terminations through a roof or through a sidewall in close proximity, they can be arranged into stacked rows of two, as shown in *Figure 47*, or lateral rows of two as shown in *Figure 48*.
2. Four is the maximum number of concentric terminations that can be installed in a group where all terminations are in close proximity as shown in *Figure 47*.

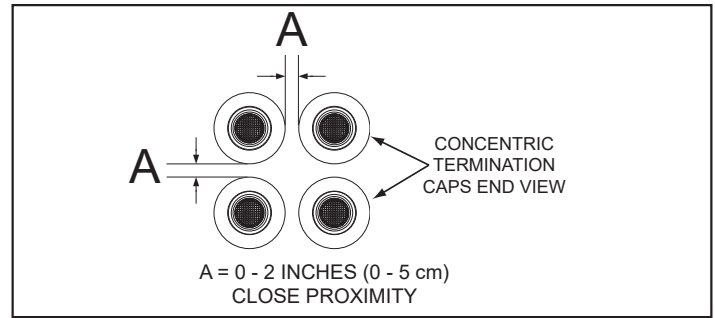

Figure 47. Four Concentric Terminations - Close Proximity

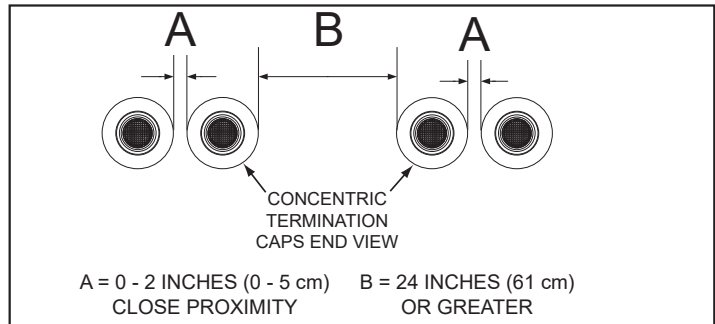

Figure 48. Four Concentric Terminations in a Line

Groups Of Terminations

1. When installing multiple groups of concentric terminations through a roof or through a sidewall in close proximity, they can be installed into stacked groups of four as shown in *Figure 52* (page 44). Lateral groups of four as shown in *Figure 49* can be a more convenient installation arrangement for multiple groups, depending on available space.

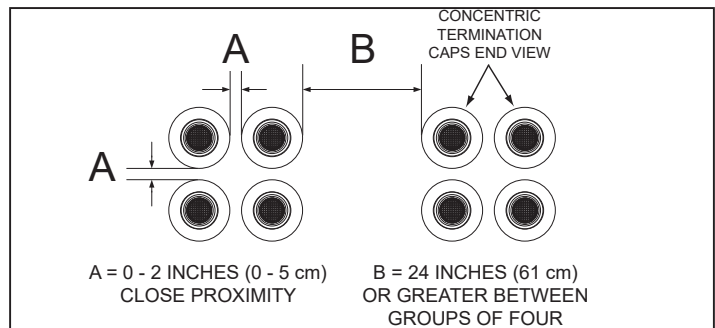

Figure 49. Eight Concentric Terminations

Multiple Concentric Termination Arrangements

The illustrations on this page show some of the installation arrangements for multiple concentric terminations that are allowed.

See *Multiple Concentric Termination Clearances* (page 42) for detailed information on clearances and additional arrangement options.

Note: When multiple concentric terminations are installed through a roof in the same location, all termination caps must be at the same height as measured from the ground.

Two Concentric Terminations

Two concentric terminations can be installed in close proximity as shown in *Figure 50* or with standard clearances when this arrangement is not possible. See *Figure 45* (page 43) for detailed information

on clearances. See *Figure 46* (page 43) when installing three concentric terminations.

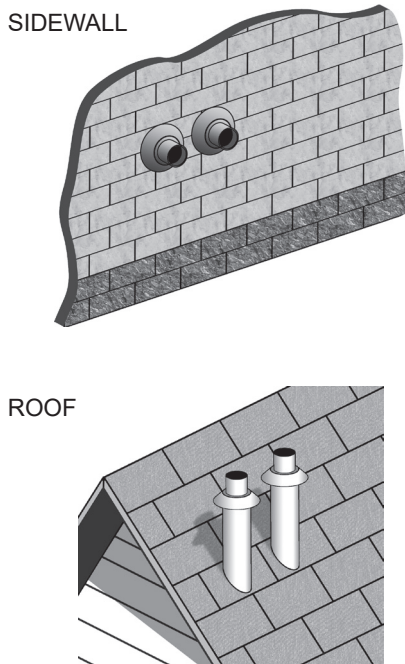

Figure 50. Two Concentric Terminations - Sidewall and Roof

Four Concentric Terminations

Four concentric terminations can be installed in close proximity as shown in *Figure 51*. See *Figure 47* (page 43) and *Figure 48* (page 43) for detailed information on clearances and additional arrangement options.

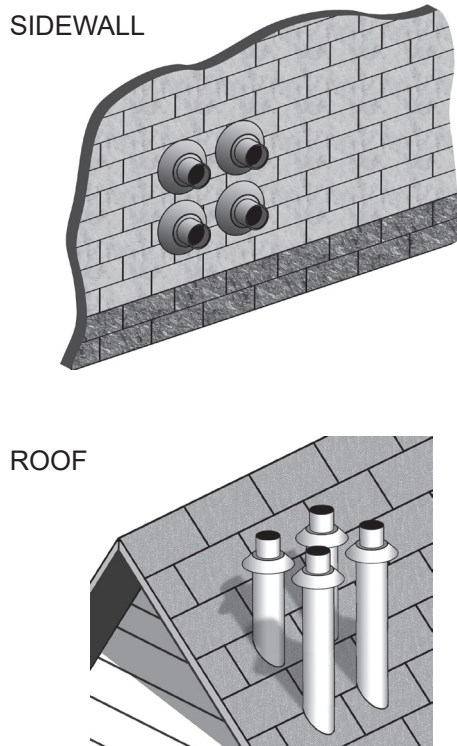

Figure 51. Four Concentric Terminations - Sidewall and Roof

Eight Concentric Terminations

Eight concentric terminations can be installed in two stacked groups of four, in close proximity, as shown in *Figure 43*. See *Figure 43* (page 42) for detailed information on clearances.

Lateral groups of four as shown in *Figure 42* (page 42) can be a more convenient installation arrangement for multiple groups depending on available space.

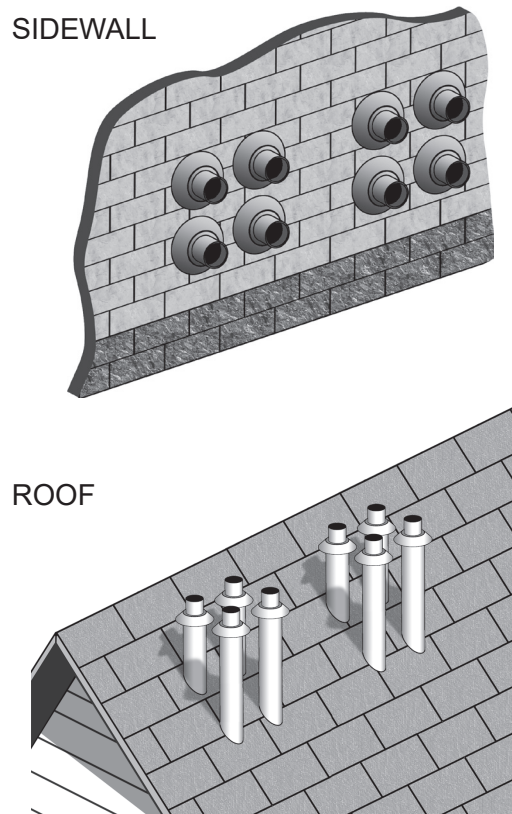

Figure 52. Eight Concentric Terminations - Sidewall and Roof

LOW PROFILE VENT INSTALLATION

This water heater is certified for sidewall direct venting with IPEX System 636 Low-Profile Vent Kit. Follow instructions below for proper installations.

All termination kits must be located and installed in accordance with local building code and *CSA B149.1 Natural Gas and Propane Installation Code*.

1. Once the proper location has been determined, cut two holes in the wall large enough to accommodate the pipe. Pipe diameters and distance between hole centers can be found in *Table 18* (page 45).
2. Slide both the intake and exhaust pipes through the holes. Solvent cement to both pipes to the base of the vent termination kit. Follow the solvent cementing procedures outlined in the *IPEX System 636 Installation Guide*, which is available on the web www.ipexinc.com.
3. To fasten the base to the wall, use the supplied screws and anchors. A 3/16 in (5 mm) hole, 1-3/16" (30mm) deep, will need to be drilled for the anchors. Locate the anchor hole using the base as a template.
4. Screw the Cap to the Base using the supplied screws.
5. Once the vent termination and pipes are secured, the wall penetrations will need to be sealed from the interior using a PVC-compatible sealant material.
6. All vent pipes and air inlets must terminate at the same height to avoid possibility of severe personal injury, death, or substantial property damage.

- Operate heater through one heat cycle to ensure combustion-air and vent pipes are properly connected to concentric vent termination.

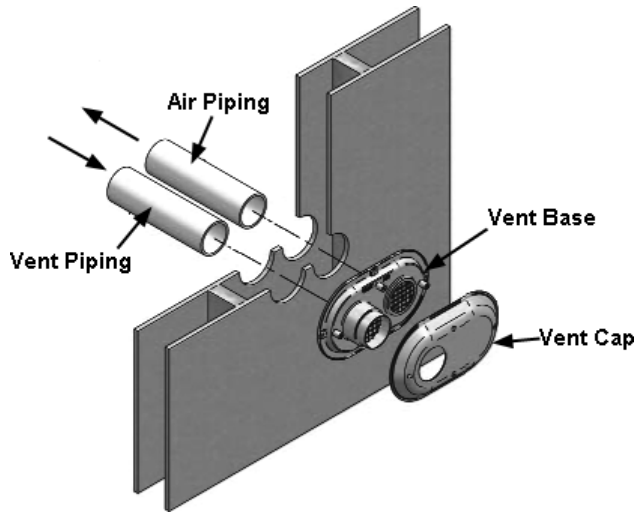

Figure 53. Inlet and Vent Flow in Low Profile Installation

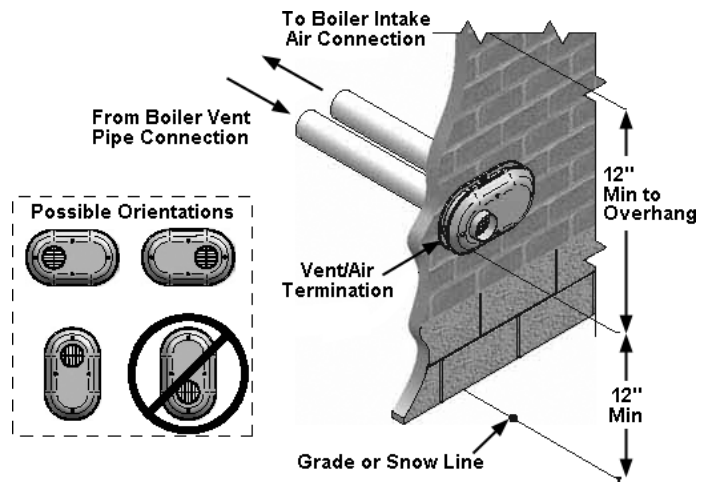

Figure 54. Inlet and Vent Flow in Low Profile Vent Installation

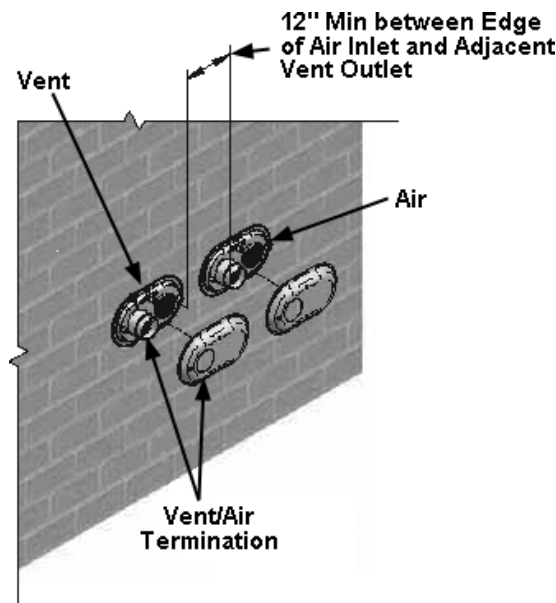

Figure 55. Multiple Low Profile Vent Clearances

Table 18. Low Profile Termination Kits - Dimensions				
Kit Number	IPEX Part Number	Description	Pipe Outside Diameter	Hole Spacing (Center to Center)
100086241	196984	2" Flush Mount Vent Kit	2.375 in (6 cm)	5.63 in (14.3 cm)
100187887	196985	3" Flush Mount Vent Kit	3.5 in (8.9 cm)	5.63 in (14.3 cm)
100187888	196986	4" Flush Mount Vent Kit	4.50 in (11.4 cm)	5.63 in (14.3 cm)
100187889	196080	6" Flush Mount Vent Kit	6.61 in (16.8 cm)	7.63 in (19.4 cm)

Table 19. Each Low Profile Termination Kit Contains	
Qty	Item Description
1	Base (two holes)
1	Cap (one hole)
8	Stainless Steel Screws
4	Plastic Anchors

VENTING ARRANGEMENTS

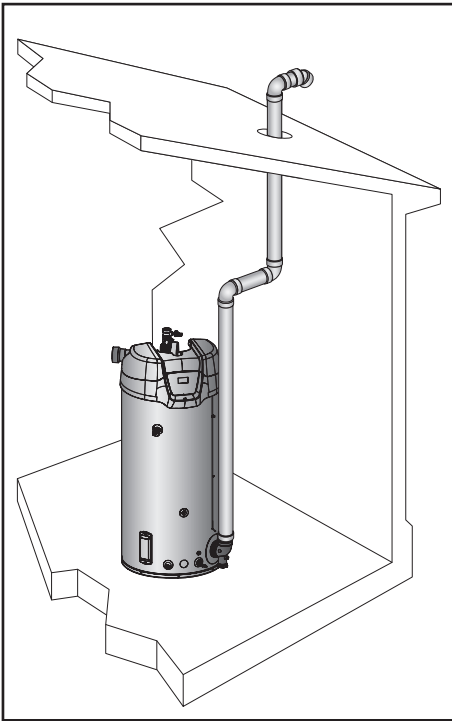

Figure 56. Power Vent Vertical

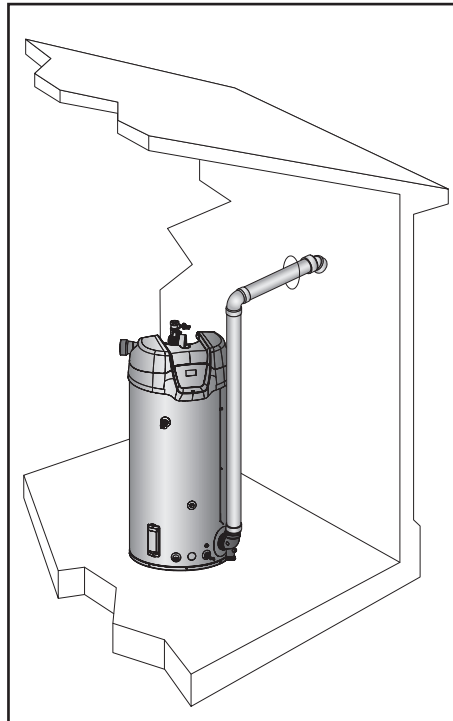

Figure 57. Power Vent Horizontal

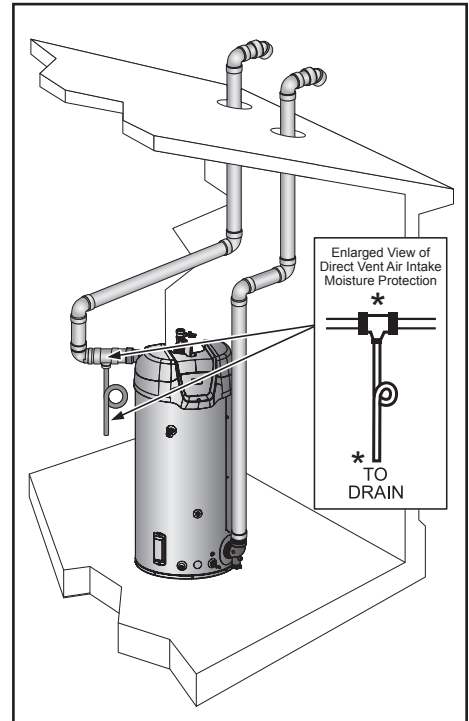

Figure 58. Direct Vent Vertical

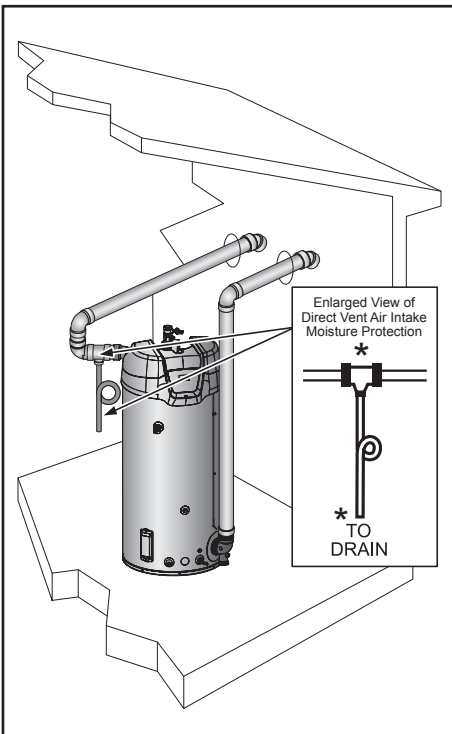

Figure 59. Direct Vent Horizontal

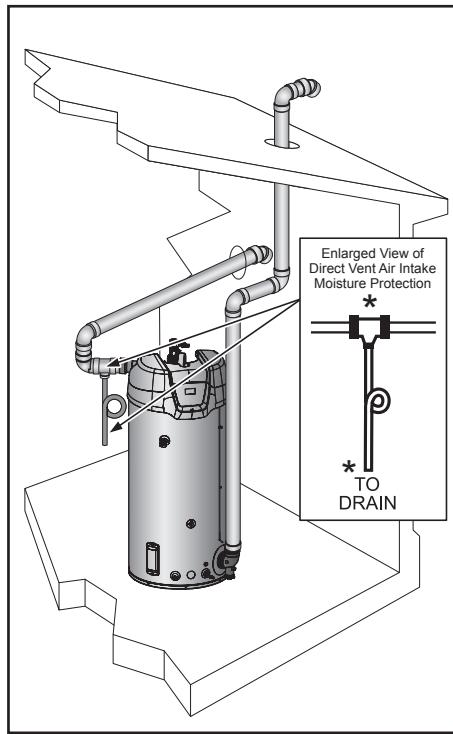

Figure 60. Direct Vent Vertical Vent Horizontal Intake

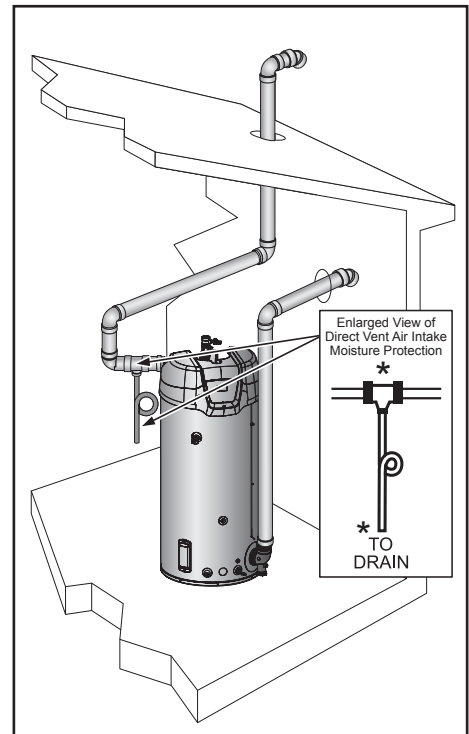

Figure 61. Direct Vent Horizontal Vent Vertical Intake

*Direct Vent combustion air intake drains are required in certain situations. See *Direct Vent Air Intake Moisture Protection* (page 36).

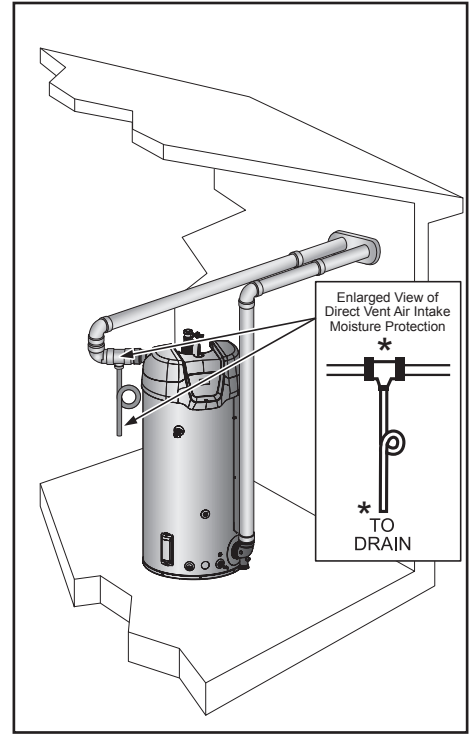
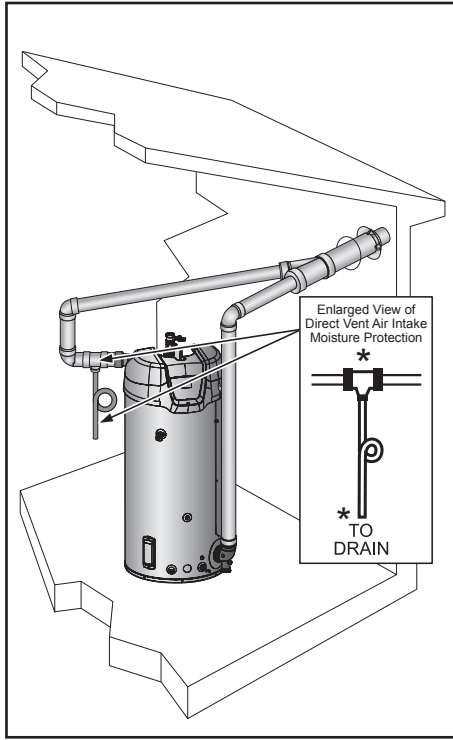
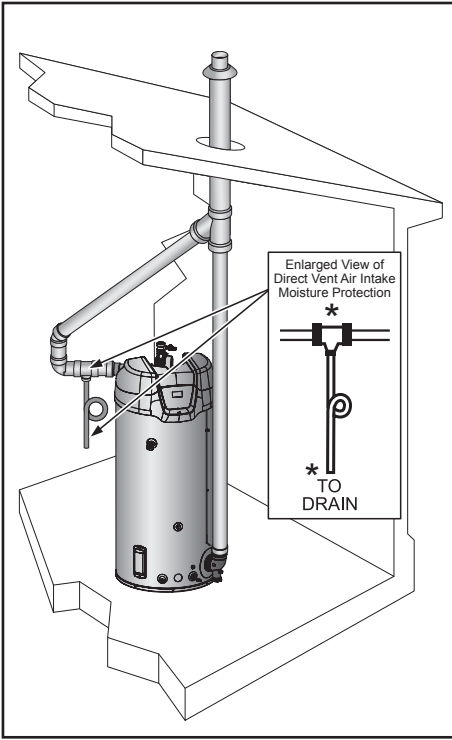

Figure 62. Direct Vent Vertical Concentric Figure 63. Direct Vent Horizontal Concentric Figure 64. Direct Vent Horizontal Low-Profile

*Direct Vent combustion air intake drains are required in certain situations. See *Direct Vent Air Intake Moisture Protection* (page 36).

TERMINATION CLEARANCES SIDEWALL POWER VENT

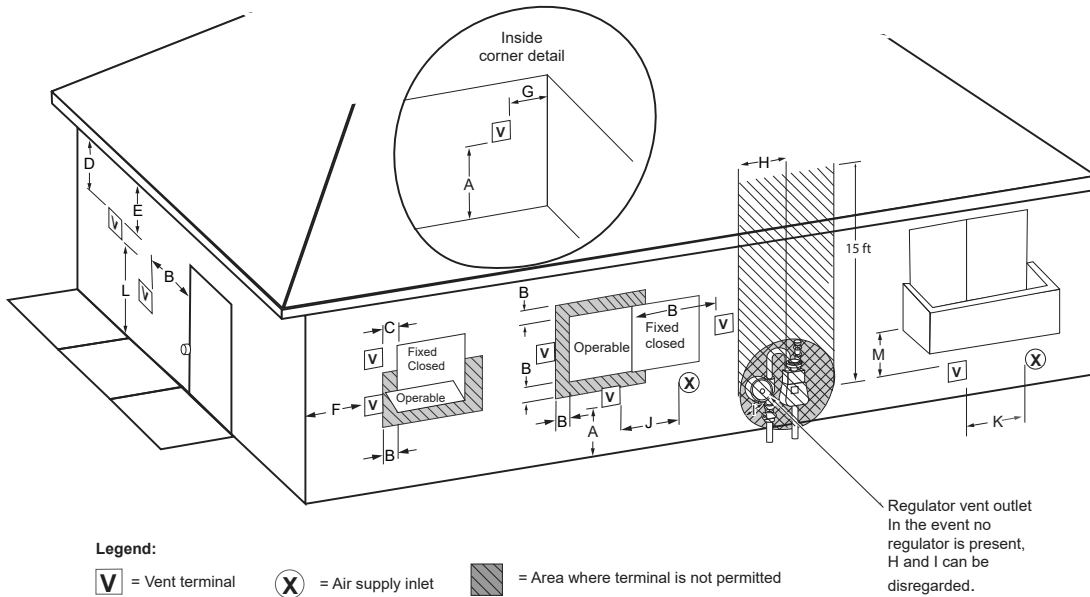

Figure 65. Sidewall Power Vent Using Outside Air

Termination Clearances for Sidewall Power Vent			
	Type of Clearance	Canadian Installations ¹	US Installations ²
A	Clearance above grade, veranda, porch, deck or balcony	12 inches (30 cm)	12 inches (30 cm)
B	Clearance to window or door that may be opened	<ul style="list-style-type: none"> 6 in (15 cm) for appliances ≤ 10,000 Btuh (3 kW) 12 in (30 cm) for appliances > 10,000 Btuh (3 kW) and ≤ 100,000 Btuh (30 kW) 36 in (91 cm) for appliances > 100,000 Btuh (30 kW) 	<ul style="list-style-type: none"> 6 in (15 cm) for appliances ≤ 10,000 Btuh (3 kW) 9 in (23 cm) for appliances > 10,000 Btuh (3 kW) and ≤ 50,000 Btuh (15 kW) 12 in (30 cm) for appliances > 50,000 Btuh (15 kW)
C	Clearance to permanently closed window	12 inches (30 cm)*	12 inches (30 cm)*
D	Vertical clearance to ventilated soffit located above the terminal within a horizontal distance of 2 feet (61 cm) from the center line of the terminal	12 inches (30 cm)*	12 inches (30 cm)*
E	Clearance to unventilated soffit	12 inches (30 cm)*	12 inches (30 cm)*
F	Clearance to outside corner	2 feet (60 cm)*	2 feet (60 cm)*
G	Clearance to inside corner	18 inches (45 cm)*	18 inches (45 cm)*

Termination Clearances for Sidewall Power Vent			
	Type of Clearance	Canadian Installations ¹	US Installations ²
H	Clearance to each side of center line extended above meter/regulator assembly	3 ft (91 cm) within a height of 15 ft (4.6 m)	Clearance in accordance with local installation codes and the requirements of the gas supplier
I	Clearance to service regulator vent outlet	3 ft (91 cm)	Clearance in accordance with local installation codes and the requirements of the gas supplier
J	Clearance to a non mechanical air supply inlet into building or combustion air inlet to any other appliance	<ul style="list-style-type: none"> 6 in (15 cm) for appliances ≤ 10,000 Btuh (3 kW) 12 in (30 cm) for appliances > 10,000 Btuh (3 kW) and ≤ 100,000 Btuh (30 kW) 36 in (91 cm) for appliances > 100,000 Btuh (30 kW) 	<ul style="list-style-type: none"> 6 in (15 cm) for appliances ≤ 10,000 Btuh (3 kW) 9 in (23 cm) for appliances > 10,000 Btuh (3 kW) and ≤ 50,000 Btuh (15 kW) 12 in (30 cm) for appliances > 50,000 Btuh (15 kW)
K	Clearance to a mechanical air supply inlet	6 feet (1.83 m)	3 feet (91 cm) above if within 10 feet (3 m) horizontally
L	Clearance above paved sidewalk or paved driveway located on public property	7 feet (2.13 m) †	7 ft (2.13 m) for mechanical draft systems (Category I appliances); vents for Category II and IV appliances cannot be located above public walkways or other areas where condensate or vapor can cause a nuisance or hazard
M	Clearance under veranda, porch, deck, or balcony	12 inches (30 cm) ‡	12 inches (30 cm) ‡

1. In accordance with the current *CSA B149.1, Natural Gas and Propane Installation Code*.

2. In accordance with the current *ANSI Z223.1/NFPA 54, National Fuel Gas Code*.

† A vent shall not terminate directly above a sidewalk or paved driveway that is located between two single family dwellings and serves both dwellings where it can cause hazardous frost or ice accumulations on adjacent property surfaces.

‡ Permitted only if veranda, porch, deck, or balcony is fully open on a minimum of two sides beneath the floor.

* Clearance in accordance with local installation codes and the requirements of the gas supplier and the manufacturer's installation instructions

TERMINATION CLEARANCES SIDEWALL DIRECT VENT

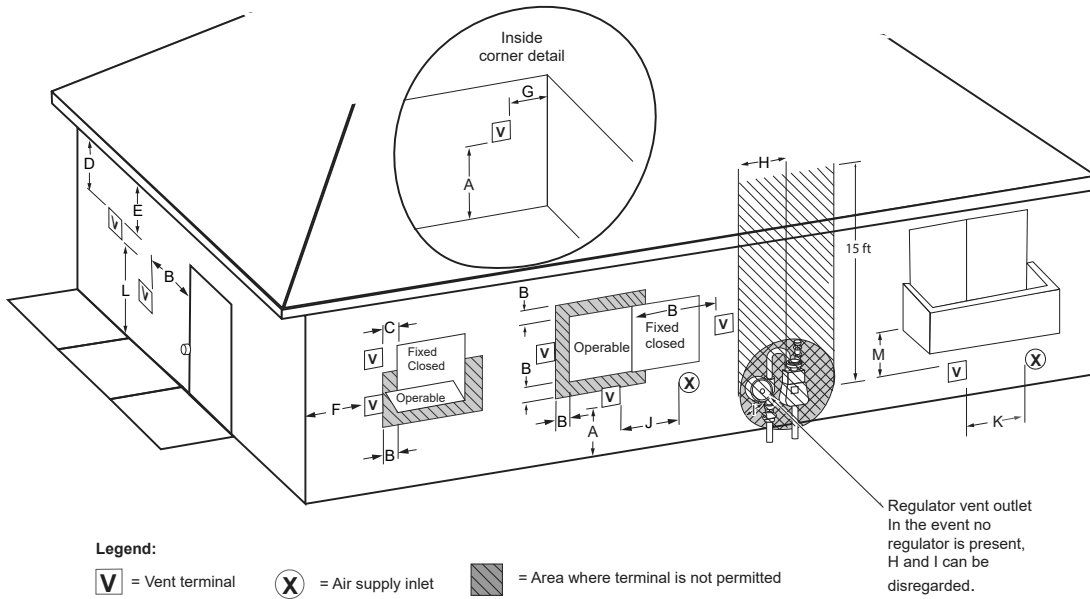

Figure 66. Sidewall Direct Vent Using Outside Air

Termination Clearances for Sidewall Direct Vent			
	Type of Clearance	Canadian Installations ¹	US Installations ²
A	Clearance above grade, veranda, porch, deck or balcony	12 inches (30 cm)	12 inches (30 cm)
B	Clearance to window or door that may be opened	<ul style="list-style-type: none"> 6 in (15 cm) for appliances ≤ 10,000 Btuh (3 kW) 12 in (30 cm) for appliances > 10,000 Btuh (3 kW) and ≤ 100,000 Btuh (30 kW), 36 in (91 cm) for appliances > 100,000 Btuh (30 kW) 	<ul style="list-style-type: none"> 4 feet (1.2 m) below or to side of opening; 1 foot (30 cm) above opening
C	Clearance to permanently closed window	6 inches (15 cm)*	6 inches (15 cm)*
D	Vertical clearance to ventilated soffit located above the terminal within a horizontal distance of 2 feet (61 cm) from the center line of the terminal	12 inches (30 cm)	12 inches (30 cm)
E	Clearance to unventilated soffit	12 inches (30 cm)	12 inches (30 cm)
F	Clearance to outside corner	2 feet (60 cm)*	2 feet (60 cm)*
G	Clearance to inside corner	18 inches (45 cm)*	18 inches (45 cm)*

Termination Clearances for Sidewall Direct Vent			
	Type of Clearance	Canadian Installations ¹	US Installations ²
I	Clearance to service regulator vent outlet	3 ft (1.83 m)	Clearance in accordance with local installation codes and the requirements of the gas supplier
J	Clearance to a non mechanical air supply inlet into building or combustion air inlet to any other appliance	<ul style="list-style-type: none"> 6 in (15 cm) for appliances ≤ 10,000 Btuh (3 kW) 12 in (30 cm) for appliances > 10,000 Btuh (3 kW) and ≤ 100,000 Btuh (30 kW) 36 in (91 cm) for appliances > 100,000 Btuh (30 kW) 	<ul style="list-style-type: none"> 4 feet (1.2 m) below or to side of opening; 1 foot (30 cm) above opening
K	Clearance to a mechanical air supply inlet	6 feet (1.83 m)	3 feet (91 cm) above if within 10 feet (3 m) horizontally
L	Clearance above paved sidewalk or paved driveway located on public property	7 feet (2.13 m) †	7 ft (2.13 m) for mechanical draft systems (Category I appliances); vents for Category II and IV appliances cannot be located above public walkways or other areas where condensate or vapor can cause a nuisance or hazard
M	Clearance under veranda, porch, deck, or balcony	12 inches (30 cm) ‡	12 inches (30 cm) ‡

¹ In accordance with the current *CSA B149.1, Natural Gas and Propane Installation Code*.

† A vent shall not terminate directly above a sidewalk or paved driveway that is located between two single family dwellings and serves both dwellings.

Where it can cause hazardous frost or ice accumulations on adjacent property surfaces.

‡ Permitted only if veranda, porch, deck, or balcony is fully open on a minimum of two sides beneath the floor.

* Clearance in accordance with local installation codes and the requirements of the gas supplier and the manufacturer's installation instructions.

INSTALLING THE WATER HEATER

CONDENSATE DRAIN INSTALLATION

Installation must conform with these instructions and local building codes.

Condensate neutralizer kits are available. Contact your distributor or Service Agency.

Field-supplied materials required for installation include:

- Approved PVC cement and PVC primer.
- 1/2 inch PVC pipe - minimum length to equal the distance between the water heater and a suitable building drain.
- 1/2 inch PVC fittings (elbows, couplings and adapters) necessary to install a condensate drain line between the exhaust/condensate elbow assembly and a suitable building drain.
- Floor mounted standoffs to brace the drain line.

Installation Notes

1. The condensate drains from the water heater's covered by this instruction have pH levels between 4.3 and 5.0. Install a commercially available neutralizing kit if required by local codes. Lower pH levels are acidic. Do not connect a metal condensate drain line, such as copper pipe, to the water heater for this reason.
2. The field-installed condensate drain line must not be less than 1/2 inch PVC in size. The condensate line must slope to an open drain.

Do not install an additional trap in the condensate drain piping. Do not remove, modify or alter the factory condensate trap.

Installation Instructions

1. Ensure that the water heater's Enable/Disable switch is in the "Disable" position.
2. Install a 1/2 inch PVC condensate drain line between the condensate drain connection on the exhaust/condensate elbow and a suitable building drain. The exhaust elbow has a "built in" condensate trap. Do not install an additional trap in the condensate drain piping. See *Figure 67*.
3. Terminate the condensate drain piping near the drain. See *Figure 67* (page 50).

Note: In cold climates it is recommended the condensate drain be terminated at a suitable drain inside the building.

4. Ensure that the condensate drain line is not elevated above the condensate drain connection on the exhaust/condensate elbow. See *Figure 67*.
5. Brace the condensate drain line with floor mounted standoffs at intervals of 3 ft (1 m).
6. Ensure that the condensate drains freely during start up. See *Start Up* (page 56).
7. Condensate clean out cap must be on and tight when unit is in operation.

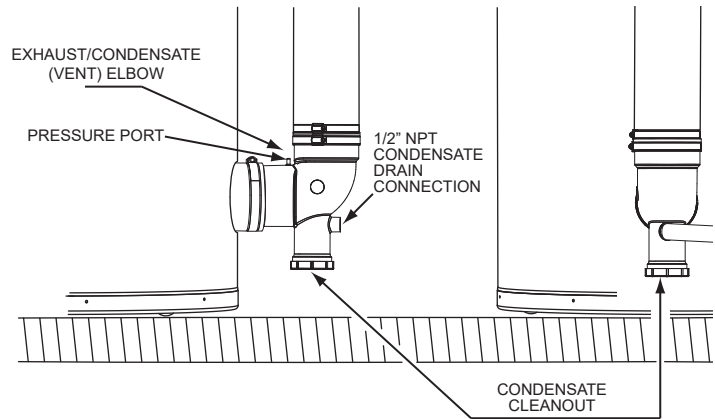

Figure 67. Condensate Drain Installation

LEAK DETECTION MODULE INSTALLATION

The water heaters covered by this manual have a water leak detection feature that senses the buildup of water in the vicinity of the appliance setting off alarm to alert the end user. Please follow installation instructions in included kit.

Note: Must be installed prior to start up.

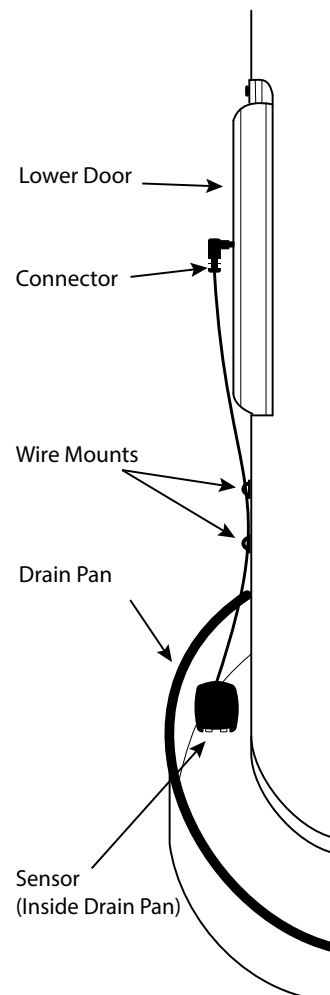

Figure 68. Leak Detection Module Installation

SUPPLY GAS LINE INSTALLATION

Contact your local gas utility company to ensure that adequate gas service is available and to review applicable installation codes for your area.

Be sure that the gas meter has sufficient capacity to supply the rated gas input of the water heater as well as the requirements of all other gas fired equipment supplied by the meter. If the gas meter is undersized, the gas company will have to install a properly sized gas meter.

⚠ **WARNING**

Fire and Explosion Hazard

- Do not use water heater with any gas other than the gas shown on the rating label.
- Excessive gas pressure to gas valve can cause serious injury or death.
- Turn off gas lines during installation.
- Contact a qualified installer or service agency for installation and service.

Make sure gas supplied is same type listed on the water heater's rating label.

Make sure gas supplied is same type listed on the water heater's rating label. The water heaters covered in this manual are not intended for operation at higher than 14.0" W. C. (3.49 kPa) for natural and propane gas supply pressure. See **Table 5** (page 18). The water heaters covered in this manual require supply gas regulators to maintain required supply gas pressure. Exposure to higher gas supply pressure may cause damage to the gas controls which could result in fire or explosion. If overpressure has occurred such as through improper testing of gas lines or malfunction of the supply system the water heater's gas valve must be replaced.

Ensure supply regulator vent lines and the safety vent valves are protected against blockage. These are components of the gas supply system, not the water heater. Vent blockage may occur during ice storms.

It is important to guard against gas valve fouling from contaminants in the gas ways. Such fouling may cause improper operation, fire or explosion. If copper supply lines are used they must be internally tinned and certified for gas service.

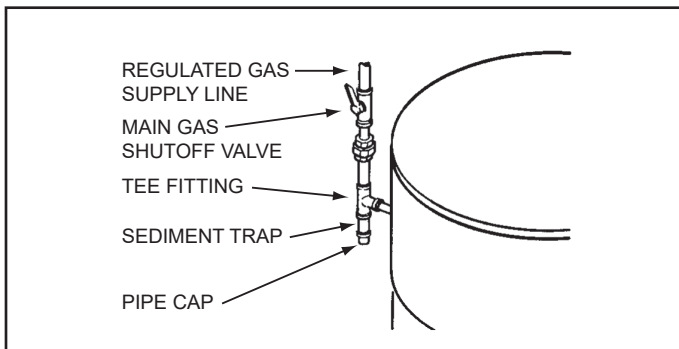

Figure 69. Supply Gas Line Installation

Ensure that all gas pipe is clean on the inside before installation. To trap any dirt or foreign material in the gas supply line a sediment trap must be installed as shown in **Figure 69**. The sediment trap must be readily accessible and not subject to freezing conditions. Install in accordance with the recommendations of the local gas utility company

Gas Line Sizing

Minimum required supply gas line sizes are shown in **Table 4** (page 18) and **Table 5** (page 18). Depending on the developed equivalent length and/or the number of appliances connected to a common main, the size of supply gas lines may have to be increased.

Size the supply/main gas line(s) in accordance with **Table 20** (page 51) and **Table 21** (page 52). The values given in **Table 20** and **Table 21** are for straight lengths of iron pipe at 0.5" W. C. (125 Pa) pressure drop, which is considered normal for low pressure systems.

Note: Fittings such as elbows and tees will add to the pipe pressure drop.

Schedule 40 Steel or Wrought Iron Pipe is the preferred material for the gas line of this water heater. It is imperative to follow the sizing recommendations in the latest version of the **National Fuel Gas Code** if Corrugated Stainless Steel Tubing (CSST) is used as the gas line for this water heater.

Length in Feet	Normal Iron Pipe Sizes (Inches) Input In Thousands Btu/Hr					
	1/2"	3/4"	1"	1 1/4"	1 1/2"	2"
10	175	360	680	1400	2100	3960
20	120	250	485	950	1460	2750
30	97	200	375	770	1180	2200
40	82	170	320	660	990	1900
50	73	151	285	580	900	1680
60	66	138	260	530	810	1520
70	61	125	240	490	750	1400
80	57	118	220	460	690	1300
90	53	110	205	430	650	1220
100	50	103	195	400	620	1150
125	44	93	175	360	550	1020
150	40	84	160	325	500	950
175	37	77	145	300	460	850
200	35	72	135	280	430	800

Table 21. Supply Gas Line Sizing Metric Units						
Length In Meters	Normal Iron Pipe Sizes (inches) Input in kW					
	1/2"	3/4"	1"	1 1/4"	1 1/2"	2"
3.0	51	105	199	410	615	1160
6.1	35	73	142	278	428	805
9.1	28	59	110	225	346	644
12.2	24	50	94	193	290	556
15.2	21	44	83	170	264	492
18.3	19	40	76	155	237	445
21.3	18	37	70	143	220	410
24.4	17	35	64	135	202	381
27.4	16	32	60	126	190	357
30.5	15	30	57	117	182	337
38.1	13	27	51	105	161	299
45.7	12	25	47	95	146	278
53.3	11	23	42	88	135	249
61.0	10	21	40	82	126	234

Gas Line Connection

The water heaters covered by this manual are shipped from the factory with a supply gas connection. See **Table 4** (page 18). Connect the supply gas line to the water heater's Gas Valve in accordance with all applicable local and national code requirements. See **Figure 70** (page 52).

1. The 60-gallon and 100-gallon gas models require a 3/4" NPT minimum supply gas line. The 119-gallon natural gas models require a 1 1/4" NPT minimum supply gas line **Gas Line Sizing** for additional information.
2. Apply thread sealing compounds (pipe dope/ thread-sealer tape) sparingly and only to the male threads of the pipe joints. Do not apply sealing compound to the first two threads. Use pipe dope or thread-sealer tape marked as being resistant to the action of liquid petroleum (LP/propane) gases.
3. Use only a smooth jaw adjustable wrench (such as a monkey wrench) as a back up on the body of the Gas Valve when tightening the first pipe nipple into the body of the valve. Do not use a standard pipe wrench (Stillson wrench) with metal tooth jaws as this may permanently damage the valve.
4. Use a standard pipe wrench (Stillson wrench) as a back up on the first pipe nipple installed above when connecting other fittings and pipe in the supply gas line to prevent Gas Valve on water heater from twisting during installation.
5. To prevent damage, care must be taken not to apply too much torque when connecting the supply gas line to the water heater.
6. Install a sediment trap as shown in **Figure 69** (page 51).
7. Install a Main Gas Shutoff valve in the supply gas line as shown in **Figure 69** (page 51).

Note: If overheating occurs or the gas supply fails to shut off, turn off the Main Gas Shutoff valve to the water heater.

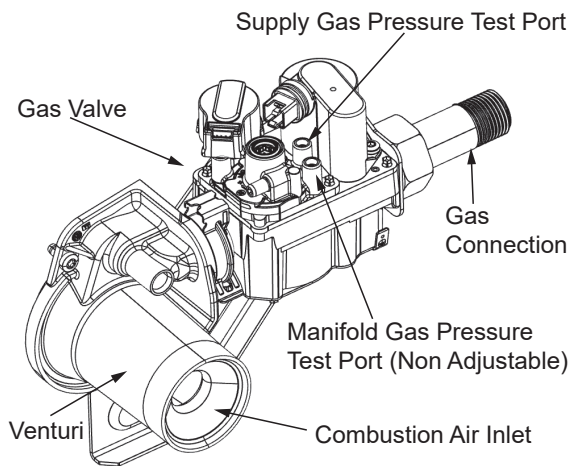

Figure 70. 60 Gallon PX52 - Supply Gas Line Connection

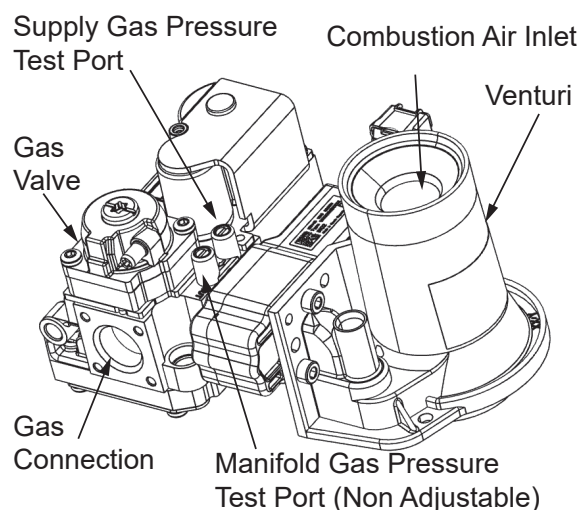

Figure 71. 100 Gallon VK - Supply Gas Line Connection

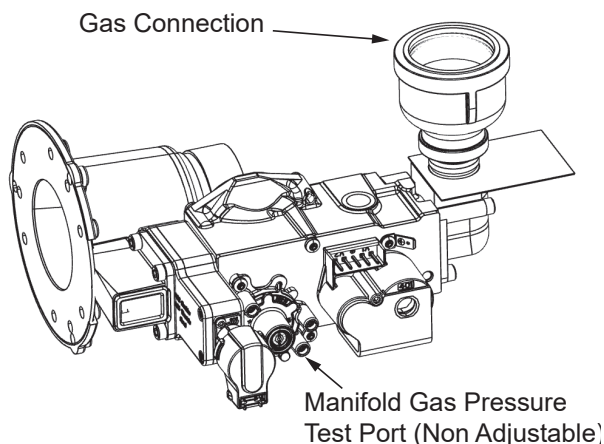



Figure 72. 119 Gallon - Supply Gas Line Connection

GAS LINE LEAK TESTING

 WARNING	
Fire and Explosion Hazard	
	<ul style="list-style-type: none">• Use joint compound or thread sealer tape compatible with propane gas.• Leak test gas connections before placing the water heater in operation.• Disconnect gas piping at main gas shutoff valve before leak testing.• Install sediment trap in accordance with NFPA 54 or CAN/CSA B149.1.

Any time work is done on the gas supply system perform a leak test to avoid the possibility of fire or explosion.

1. For test pressures exceeding 0.5 psi (3.45 kPa) disconnect the water heater and its Main Gas Shutoff Valve from the gas supply piping system during testing. See **Figure 50** (page 44). The gas supply line must be capped when disconnected from the water heater.
2. For test pressures of 0.5 psi (3.45 kPa) or less, the water heater need not be disconnected, but must be isolated from the supply gas line by closing the Main Gas Shutoff Valve during testing.
3. Paint all supply gas line joints and connections upstream of the water heater with a chloride-free liquid leak detection solution to test for leaks. Bubbles indicate a gas leak. Do not use matches, candles, flame or other sources of ignition for this purpose.
4. Turn off gas supply and repair any leaks before placing the water heater in operation.

Purging

Gas line purging is required with new piping or systems in which air has entered. Purging should be performed per the current edition of **NFPA 54** the *National Fuel Gas Code*.

ELECTRICAL WIRING

All electrical work must be installed in accordance with the *National Electrical Code*, **ANSI/NFPA 70** or the *Canadian Electrical Code*, **CSA C22.1** and local requirements.

When installed, the water heater must be electrically grounded in accordance with local codes or, in the absence of local codes, with the *National Electrical Code*, **ANSI/NFPA 70** or the *Canadian Electrical Code*, **CSA C22.1**.

If any of the original wire as supplied with the water heater must be replaced, replacement harnesses are available through Service Parts.

Dedicated Power Wiring and Breakers

Dedicated power supply wires, ground wiring and dedicated circuit breakers often prevent electrical line noise and are required when installing the water heater.

Note: Dedicated power supply wires, ground wiring and dedicated circuit breakers often prevent electrical line noise and are required when installing the water heater **NFPA 70**, **CSA C22.1** and **UL 943**.

Power Supply Connections

See the requirements for the **Power Supply** (page 21) before connecting power.

The 120 VAC hot wire from the power supply must connect to the black jumper wire or the “L1” terminal block location in the junction box and the 120 VAC neutral wire must connect to the white jumper wire or the “Neutral” terminal block location in the junction box for correct polarity. See **Figure 73**.

Power supply connections must be made as follows:

1. Turn off the enable/disable switch to disable heating operation.
2. Turn off power to the water heater at the breaker that supplies power to the water heater.
3. Remove the junction box cover. See **Figure 5**, **Figure 6** and **Figure 7** (pages 11 through 13) for junction box location.
4. Connect the 120 VAC hot wire from the power supply to the black jumper wire or the terminal block location marked “L1” inside of the junction box located on top of the water heater. If the black jumper wire is used, make the connection inside of the junction box with a properly sized wire nut and wrap electrical tape around the wire nut and wire end. See **Figure 73** (page 54) and wiring diagrams, **Figure 88** (page 102), **Figure 89** (page 103), and **Figure 90** (page 104).
5. Connect the 120VAC neutral wire from the power supply to the white jumper wire or the terminal block location marked “Neutral” inside of the junction box located on top of the water heater. If the white jumper wire is used, make the connection inside of the junction box with a properly sized wire nut and wrap electrical tape around the wire nut and wire end. See **Figure 73** (page 54) and wiring diagrams, **Figure 88** (page 102), **Figure 89** (page 103), and **Figure 90** (page 104).
6. Connect the ground wire from the power supply to the green jumper wire or the ground terminal location inside of the junction box located on top of the water heater. If the green jumper wire is used, make the connection inside of the junction box with a properly sized wire nut and wrap electrical tape around the wire nut and wire end. See **Figure 73** (page 54) and wiring diagrams, **Figure 88** (page 102), **Figure 89** (page 103), and **Figure 90** (page 104).
7. Replace the junction box cover when connections are complete.

Note: If electrical connections are made directly to the terminal block remove the jumper wires before making connection.

Note: Do not apply power to the water heater before installation is complete and the water heater is filled with water.

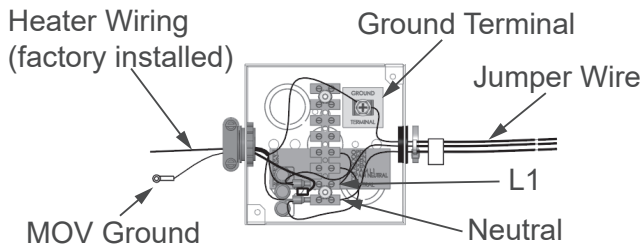

Figure 73. Power Supply Connections

Note: Ensure that the water heater is protected from freezing temperatures when water heating operation is disabled. Damage to the water heater caused by freezing temperatures is not covered under the limited warranty.

External Enable-Disable Circuit

The water heaters covered in this manual are equipped with an enable/disable circuit for use with field-supplied supervisory controls such as time clocks or Building Management Systems. The enable/disable circuit may be used to disable heating operation during periods when the building is unoccupied or there is no demand for hot water. To use the enable/disable circuit it must first be activated by selecting “use External Enable” from the UIM. Field support wiring is then installed between the water heater’s controls and a set of dry contacts (no voltage or load) on the field-supplied external control. See the wiring diagrams, *Figure 88 (page 102)*, *Figure 89 (page 103)*, and *Figure 90 (page 104)*.

WATER LINE CONNECTIONS

The water piping installation must conform to these instructions and to all local and national code authority having jurisdiction. Good practice requires that all heavy piping be supported.

Read and observe all requirements in the following sections before installation of the water piping begins:

1. *Mixing Valves* (page 22).
2. *Dish-washing Machines* (page 22).
3. *Temperature-Pressure Relief Valve* (page 22).
4. *Closed Water Systems* (page 22) and *Thermal Expansion* (page 22).
5. For multiple water heater installations, see *Water Piping Diagrams* (page 105).

Water Piping Diagrams

This manual provides detailed water piping diagrams for typical methods of application for the water heaters. See *Water Piping Diagrams* (page 105).

The water heater may be installed with or without a separate storage tank. When used with a separate storage tank, the circulation may be either by gravity or by means of a circulating pump. When a circulating pump is used, it is important to note that the flow rate should be slow so that there will be a minimum of turbulence inside the water heater storage tank.

Adjust flow by throttling a full port ball valve installed in the circulating line on the outlet side of the pump. Never throttle flow on the suction side of a pump. See *Water Piping Diagrams* (page 105).

Note: In addition to the factory-installed Temperature-Pressure Relief Valve (T&P valve) on the water heater, each remote storage tank that may be installed and piped to a water heating

appliance must also have its own properly sized, rated and approved Temperature-Pressure Relief Valve installed.

Thermometers

Thermometers (not supplied) are installed in the water piping system as a means of detecting the temperature of the hot water supply at critical points in the system. Field-supplied thermometers should be obtained and installed. See *Water Piping Diagrams* (page 105).



Water (potable) Heating And Space Heating

1. All water piping components connected to the water heater that are for space heating applications shall be suitable for use with potable water.
2. Toxic chemicals, such as those used for boiler treatment, must NEVER be introduced into this system.
3. The water heaters covered in this manual may never be connected to any existing heating system or component(s) previously used with non-potable water heating appliance.
4. When the system requires water for space heating that exceed safe temperatures at domestic water fixtures a mixing valve must be installed. See *Mixing Valves* (page 22).
5. These water heaters cannot be used in space heating applications only.

T&P Valve Discharge Pipe

⚠ WARNING	
Explosion Hazard	
	<p>Normal operation of the water heater can cause it to become sufficiently over-heated and/or over-pressurized that it can explode, resulting in property damage, sever injury, or death.</p> <p>To avoid this hazard, you must install a properly-sized temperature-pressure relief valve in opening provided.</p> <ul style="list-style-type: none"> • The temperature-pressure relief valve must comply with ANSI Z21.22-CSA 4.4 and ASME code. • Do not plug, block, or cap the discharge line.

This water heater is provided with a properly rated/sized and certified combination temperature - pressure (T&P) relief valve by the manufacturer. See *Temperature-Pressure Relief Valve* (page 22) for information on replacement and other requirements.

 CAUTION	
Property Damage Hazard	
	<p>While the water heater is in routine operation, it can release hot water from the temperature-pressure relief valve discharge pipe in quantities that could cause damage to the surroundings.</p> <p>Locate the water heater near an adequate drain and in an area where water from the temperature-pressure relief valve discharge pipe will not result in damage to the area of the lower floors of the structure.</p>

T&P Valve Discharge Pipe Requirements:

- Shall not be smaller in size than the outlet pipe size of the valve, or have any reducing couplings or other restrictions.
- Shall not be plugged or blocked.
- Shall not be exposed to freezing temperatures.
- Shall be of material listed for hot water distribution.
- Shall be installed so as to allow complete drainage of both the Temperature-Pressure Relief Valve and the discharge pipe.
- Must terminate a maximum of six inches above a floor drain or external to the building. In cold climates, it is recommended that the discharge pipe be terminated at an adequate drain inside the building.
- Shall not have any valve or other obstruction between the relief valve and the drain.

Install a discharge pipe between the T&P valve discharge opening and a suitable floor drain. Do not connect discharge piping directly to the drain unless a 6" (15.2 cm) air gap is provided. To prevent bodily injury, hazard to life, or property damage, the relief valve must be allowed to discharge water in adequate quantities should circumstances demand. If the discharge pipe is not connected to a drain or other suitable means, the water flow may cause property damage.

START UP

PRIOR TO START UP

Installation and start up of this water heater requires abilities and skills equivalent to that of a licensed tradesman in the field involved, see *Qualifications* (page 8).

DO NOT USE THIS APPLIANCE IF ANY PART HAS BEEN EXPOSED TO FLOODING OR WATER DAMAGE. Immediately call a qualified service agency to inspect the appliance and to make a determination on what steps should be taken next.

If the unit is exposed to the following, do not operate heater until all corrective steps have been made by a qualified service agency.

1. External fire.
2. Damage.
3. Firing without water.

Light the water heater in accordance with the Lighting and Operation Instruction label on the water heater and in this manual on page 60.

The water heaters covered by this manual are equipped with an electronic control system, which automatically sequences the Combustion Blower, pre- and post-purging of the combustion chamber, the spark generator, the Gas Valve, Main Burner ignition, and flame sensing. See *Control System Operation* (page 65). The control system will lock out after three unsuccessful ignition attempts.

Before attempting start up, thoroughly study and familiarize yourself with the exact sequence of operation. See *Sequence of Operation* (page 83).

Be certain that the water heater is full of water, that air is purged from the gas and water lines and that there are no leaks in the gas and water lines. It is recommended to purge air from the furthest hot water fixture preferably at the highest point. Ensure that all inlet water valves are open.

Filling The Water Heater

Follow these steps to fill the water heater prior to start up.

1. Close the heater drain valve.
2. Open a nearby hot water faucet to permit the air in the system to escape.
3. Fully open the cold water inlet valve allowing the piping and water heater to fill with water.
4. Close the hot water faucet opened in Step 2 as water starts to flow.
5. Follow the steps in *Start Up* (page 56).

INITIAL START UP AND AIQ™ CALIBRATION

At the initial start up of the water heater, the gas type will be selected and an initial calibration routine must run. AiQ™ aligns the combustion system during calibration and verifies flame signal detection. AiQ acts as the water heater's built-in start-up checklist that is designed to protect performance and efficiency. This initial calibration may take up to 15 minutes. During this initialization, any burner heat demand will be blocked.

Initial calibration should be performed if a unit has NEVER completed a calibration, after installation, or after parts have been changed. If

the Main Menu and/or "uncalibrated" appears on the display, power cycle the heater to have this initial calibration appear. Calibration is critical for efficiency and overall performance. During calibration, the Combustion Safety Control (CSC) monitors the system for a proper flame, which depends on intake air piping, exhaust piping, and the quality of the supplied fuel.

Calibration Steps

1. Power on the water heater - After installation is complete, power up the unit.
2. Enable the heater to start calibration. Follow the steps in *Gas Type Calibration* (page 57).
3. Calibration completion:
 - If successful, the heater enters normal operation.
 - If unsuccessful after 15 minutes: The heater will lock out with an error code. The common error codes are: "Calibration Error" and "Ignition Failure."

If Calibration Does Not Complete:

Common causes of calibration failure and/or ignition failure are:

Component issues

- Dirty burner - caused from new construction debris
- Gas valve assembly
- Igniter gap out of specification
- Flame sensor misaligned
- Loose or disconnected wiring

Installation deficiencies

- Insufficient gas volume or pressure
- Incorrect exhaust vent pipe
- Incorrect intake air pipe

After calibration, the continuous monitoring function becomes active. This function can trigger a new calibration in case a gas quality change is detected or there is a manual intervention by a qualified service technician.

Troubleshooting Failed Calibration

- Evaluate the installation thoroughly before attempting another calibration.
- Correct installation deficiencies before replacing components.
- If "Uncalibrated" appears in the upper left part of the display, cycle main power to reach the calibration screen.

Required Test Equipment

One U-tube manometer, recommended ranges; 0-14" W.C. (0--3.5 kPa) and 0-35" W.C. (0-8.7 kPa) or pressure gauges.

One digital manometer can be used in place of U-tube manometers or pressure gauges. Recommended ranges; -20.00 to + 20.00" W.C. (0-3.5 kPa) resolution 0.01" W.C. and 0-35" W.C. (0-8.7 kPa) resolution 0.10" W.C.

Note: All test equipment must be acclimated to ambient temperature before calibration and use.

GAS TYPE CALIBRATION

At the initial start up of the heater the gas type selection screen will appear. Please insure the correct gas type is selected when starting the calibration process. This initial calibration may take up to 15 minutes.

After calibration, the continuous monitoring function becomes active. This function can trigger a new calibration in case a gas quality change is detected or there is a manual intervention by the qualified service technician.

During this initialization, any burner heat demand will be blocked.

1. Select the correct gas type upon startup.

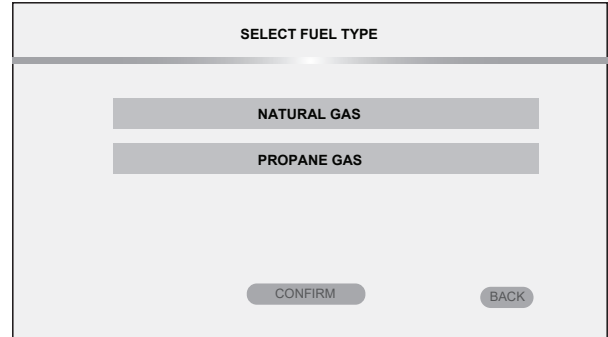

1. Click 'Confirm' to proceed with the calibration.

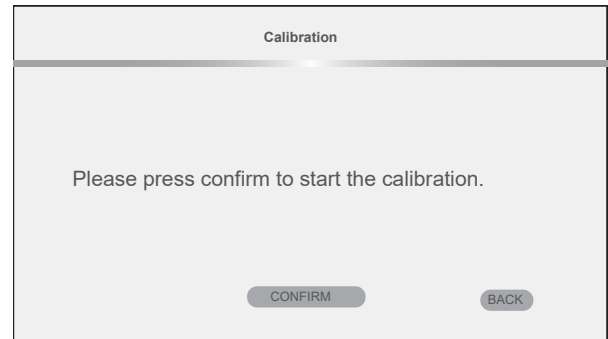

2. Set the date and time, then click Confirm to continue with the calibration.

Calibration will begin and progress screen will display.

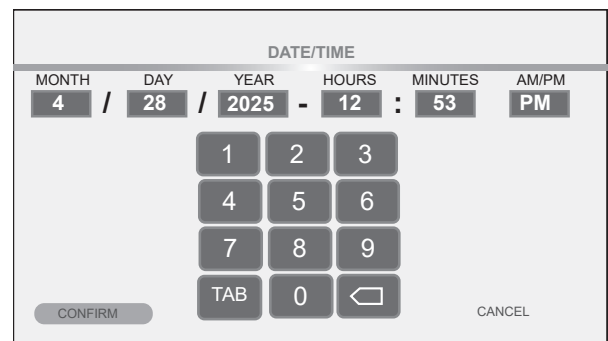

3. The calibration process will begin and show its progress on the screen.

Note: Calibration may take up to 15 minutes.

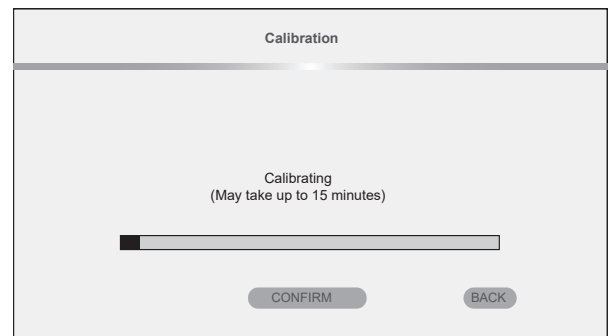

- When the calibration is complete, click BACK to return to the home screen.

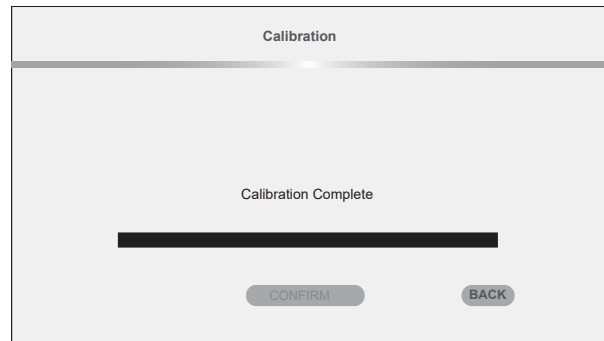

START UP CONDITIONS

Smoke/Odor

It is not uncommon to experience a small amount of smoke and odor during the initial start-up. This is due to burning off of oil from metal parts, and will disappear in a short while.

THERMAL EXPANSION

CAUTION	
Property Damage Hazard	
	<p>Avoid water heater damage from pressure fluctuations in closed water systems.</p> <ul style="list-style-type: none"> • Fill tank with water before operating. • Install thermal expansion tank if necessary. • Do not apply heat to cold water inlet. • Contact qualified installer or service agency.

Water supply systems may, because of such events as high line pressure, frequent cut-offs, the effects of water hammer among others, have installed devices such as pressure reducing valves, check valves, back flow preventers, etc. to control these types of problems. When these devices are not equipped with an internal by pass, and no other measures are taken, the devices cause the water system to be closed. As water is heated, it expands (thermal expansion) and closed systems do not allow for the expansion of heated water.

The water within the water tank expands as it is heated and increases the pressure of the water system. If the relieving point of the water heater's temperature-pressure relief valve is reached, the valve will release excess pressure. The temperature-pressure relief valve is not intended for the constant relief of thermal expansion. This is an unacceptable condition and must be corrected. It is recommended that any devices installed which could create a closed system have a by-pass and/or the system have an expansion tank or device to relieve the pressure built by thermal expansion in the water system. Expansion tanks are available for ordering through a local plumbing contractor. Contact the local water heater supplier or qualified service agency for assistance in controlling these situations.

OPERATIONAL CONDITIONS

Do not remove the powered anode rod leaving the tank unprotected. By doing so, all warranty on the water heater tank is voided.

Having the 120 v power to the water heater turned off for extended periods of time also leaves the tank unprotected and can void the warranty.

Air In Hot Water Faucets

WARNING	
Explosion Hazard	
	<p>Flammable hydrogen gases can form in water pipes. The hydrogen can explode if it is exposed to flame and can cause severe injury or death.</p> <p>Keep all ignition sources away from faucet when turning on hot water.</p>

HYDROGEN GAS: Hydrogen gas can be produced in a hot water system that has not been used for a long period of time (generally two weeks or more). Hydrogen gas is extremely flammable and explosive. To prevent the possibility of injury under these conditions, we recommend the hot water faucet, located farthest away, be opened for several minutes before any electrical appliances which are connected to the hot water system are used (such as a dishwasher or washing machine). If hydrogen gas is present, there will probably be an unusual sound similar to air escaping through the pipe as the hot water faucet is opened. There must be no smoking or open flame near the faucet at the time it is open.

START-UP PROCEDURE

- Using the control system menus, change the Operating Set Point to the lowest temperature setting. See *Operating Set Point and Differential Adjustment* (page 67) .
- Turn the water heater's Enable/Disable switch to the "Disable" position.
- Close the Main Gas Shut Off Valve.
- Wait five minutes for any residual gas to clear.
- Connect manometer to the supply gas pressure port on the gas valve.
- On the water heaters covered by this manual there are test ports for supply and manifold gas pressure readings on the gas valve. Using a small flat tip pocket screw driver - open the needle valve inside the supply gas pressure test port one full turn only (do not fully remove the needle valve), then turn the needle valve screw counter-clockwise to open the valve. Slide the manometer sensing tube over the top of the test port. See *Figure 74*.
- Slowly open the supply gas isolation valve.
- Purge the manometer tubing before taking any readings.

- Measure and record the supply gas pressure, this is a “static” supply gas pressure reading; while the water heater is not firing. When applicable, adjust the supply gas pressure at the gas supply regulator for the water heater See *Supply Gas Pressure Adjustment* (page 61).

Note: The manometer tubing should be purged before taking any readings.

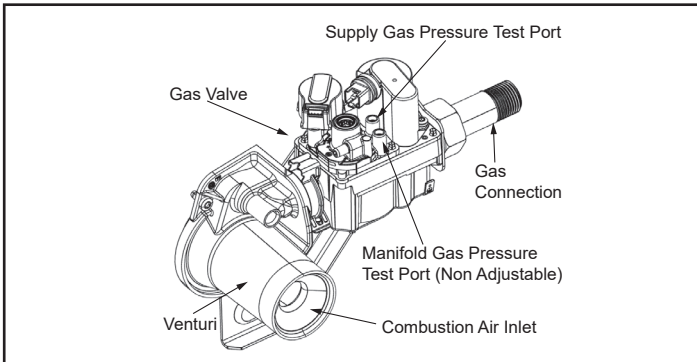

Figure 74. 60 Gallon_PX52 - Gas Valve Assembly

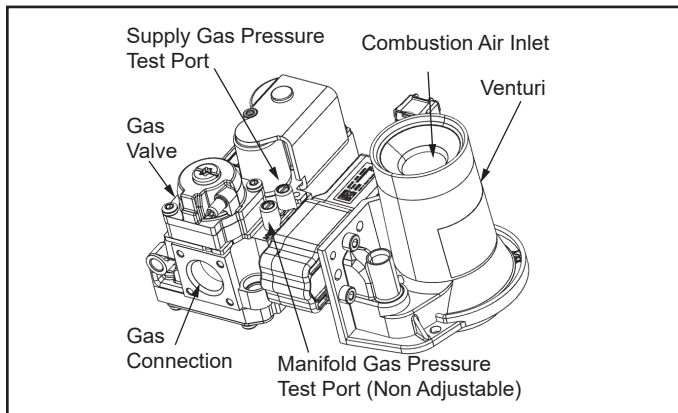

Figure 75. 100 Gallon VK - Gas Valve Assembly

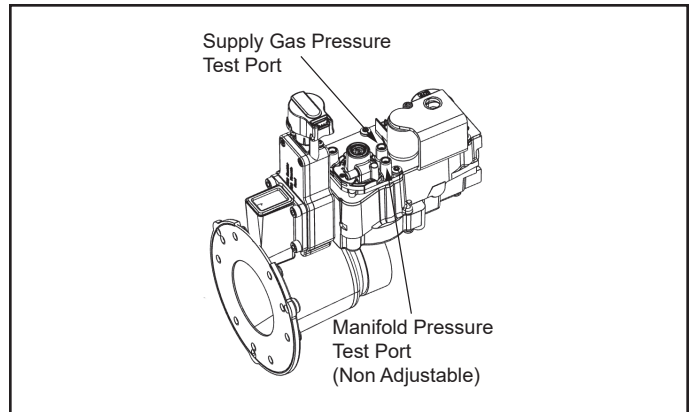



Figure 76. 119 Gallon - Gas Valve Assembly

LIGHTING THE WATER HEATER

The instruction label below is affixed to the water heaters that are covered by this manual at the factory and must be followed when lighting and operating the water heater.

FOR YOUR SAFETY READ BEFOR LIGHTING



**WARNING:** If you do not follow these instructions exactly, a fire or explosion may result causing property damage, personal injury, or loss of life.



BEFORE OPERATING: ENTIRE SYSTEM MUST BE FILLED WITH WATER AND AIR PURGED FROM ALL LINES

A. This appliance does not have a pilot. It is equipped with an ignition device which automatically lights the burner. Do not try to light the burner by hand. • **If you cannot reach your gas supplier, call the fire department.**

B. BEFORE OPERATING, smell all around the appliance area for gas. Be sure to smell next to the floor because gas is heavier than air and will settle to the floor. C. Use only your hand to push in the control buttons. Never use tools. If the control buttons will not push in, don't try to repair them, call a qualified service technician. Force or attempted repair may result in fire or explosion

“WHAT TO DO IF YOU SMELL GAS”

- Do not try to light the appliance.
- Do not touch any electrical switch; do not use any telephone in your building.
- Immediately call your gas supplier from a neighbor's phone. Follow the gas supplier's instructions.

D. Do not use this appliance if any part has been under water. Immediately contact a qualified installer or service agency to replace a flooded water heater. Do not attempt to repair the service unit. It must be replaced.

OPERATING INSTRUCTIONS

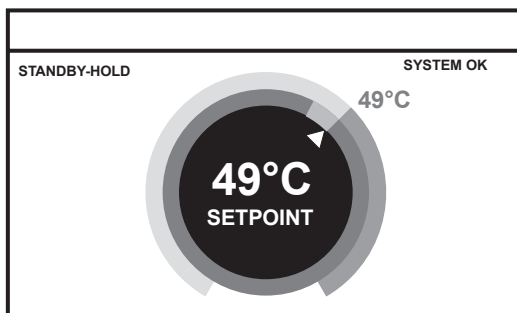

ENABLE/DISABLE SWITCH

1.  STOP! Read the safety information above on this label
2. Set the Enable/Disable switch on the control panel to the Enable position.
3. Set the thermostat to the lowest setting.
4. Set the Enable/Disable switch on the control panel to the Disable position.

5. This appliance is equipped with a device which automatically lights the burner. **DO NOT TRY TO LIGHT THE BURNER BY HAND.**

6. Wait five (5) minutes  to clear out any gas. If you then smell gas, STOP! Follow “B” in the safety information above on this label. If you don't smell gas, go to the next step.

7. Turn on all electrical power to the appliance.

8. Set the Enable/Disable switch on the control panel to the Enable position.

9. Set the thermostat to the desired setting.



 **CAUTION: Hotter water increases the risk of scald injury. Consult the instruction manual before changing temperature**

10. If the appliance will not operate, follow the instructions “TO TURN OFF GAS TO APPLIANCE” and call your technician or gas supplier.

 **WARNING: TURN OFF ALL ELECTRIC POWER BEFORE SERVICING.**

TO TURN OFF GAS TO APPLIANCE

1. Set the thermostat to the lowest setting.
2. Set the Enable/Disable switch on the control panel to the Disable position.
3. Turn off all electrical power to the appliance if service is to be performed.

 WARNING	
Fire and Explosion Hazard	
	<ul style="list-style-type: none"> • Do not use water heater with any gas other than the gas shown on the rating label. • Excessive gas pressure to gas valve can cause serious injury or death. • Turn off gas lines during installation. • Contact a qualified installer or service agency for installation and service.

Supply gas pressure shall be measured while the water heater is not firing (static pressure) **and** while the water heater is firing at full capacity (dynamic pressure).

If the supply gas pressure to the water heater is not between the required minimum and maximum values given in **Table 5** (page 18) adjust the supply gas regulator as necessary. Adjust the supply gas regulator(s) per the regulator manufacturer’s instructions to achieve the required “static” supply gas pressure. The dynamic pressure will be directly proportional to the static pressure. The dynamic pressure cannot be adjusted directly but is directly proportional to the static pressure.

Multiple Appliance Installations:

In multiple water heater installations or in installations where the installed water heater(s) share a common gas supply main with other gas fired appliances; the supply gas pressures shall be measured at each water heater with all gas fired appliances connected to a common main firing at full capacity.

On multiple water heater installations the supply gas line regulators shall be adjusted to provide gas pressure to each water heater within the minimum and maximum supply pressure requirements listed in **Table 5** (page 18) with all gas fired appliances connected to a common gas main firing at full capacity.

Note: A pressure drop of more than 1.5” W. C. (0.37 kPa) when the Main Burner ignites is an indication of an inadequate supply of gas and can lead to ignition failure, rough starts and/or rough operation. If a drop of more than 1.5” W. C. (0.37 kPa) in supply gas pressure occurs when the Main Burner ignites, ensure that the supply gas lines and regulator(s) are properly sized and installed. See the requirements for the supply gas line in **Table 4** (page 18) and **Table 5** (page 18) and the instructions in **Supply Gas Line Installation** (page 51). See the requirements for **Supply Gas Regulator** (page 21). Ensure that all requirements and installation instructions are maintained.

CHECKING THE FIRING RATE

Follow these instructions to determine the actual firing rate of the water heater:

1. Ensure that there are no other gas fired appliances connected to the gas meter firing during this test.
2. Contact the gas supplier to determine the heating value, in Btu per cubic foot, of the gas supply.
3. Start the water heater and ensure it is firing.
4. Locate the gas meter serving the water heater.
5. Time how long (in seconds) it takes for one cubic foot of gas to be used while the water heater is firing with a stop watch.
6. Use the formula below to “clock” the gas meter and determine the actual firing rate of the water heater based on the heating value (Btu per cubic foot) of the gas supply:

$$\frac{3600}{T} \times H = \text{Btu/hr}$$

Example:

$$\frac{3600}{12.6} \times 1050 = 300,000 \text{ Btu/hr (87.9 kW)}$$

- 3600 = seconds in one hour.
- T = time, in seconds, to burn one cubic foot of gas.
- H = heating value of gas in Btu per cubic foot.
- Btu/hr = actual firing rate of the water heater.



Note: 1050 Btu per cubic foot is a standard value for natural gas. Standard propane gas Btu content is 2500 Btu per cubic foot. Btu values may change in certain areas and at high elevations. Check with the local gas utility company.



To Turn Off Gas Supply

1. Change the Operating Set Point to the lowest temperature setting. See **Operating Set Point and Differential Adjustment** (page 67).
2. When the water heater has completed its shut down sequence and enters the standby mode, turn the water heater’s Enable/Disable switch to the “Disable” position. When in the “Disable” position the switch only removes electrical power from the gas valve so that water heating is disabled. The display, Control board, and other electrical components will still be energized and the display will read “Water Heating Disabled.”
3. Close the Main Gas Shutoff Valve. See **Figure 69** (page 51).

HIGH ALTITUDE INSTALLATIONS

The water heaters covered by this manual are certified for use without modification for altitudes up to 10,100 feet.

 WARNING	
Fire and Explosion Hazard	
	<p>Modifying the water heater to exceed the firing rate on the rating label can result in property damage, personal injury or death.</p> <ul style="list-style-type: none">• Under no circumstances should the input exceed the rate shown on the water heater's rating label.• Over-firing could result in fire or explosion.• Gas and carbon monoxide detectors are available.

 WARNING	
Breathing Hazard - Carbon Monoxide Gas	
	<ul style="list-style-type: none">• Under no circumstances should the input exceed the rate shown on the water heater's rating label.• Overfiring could result in damage to the water heater and sooting.• Gas and carbon monoxide detectors are available.
Breathing carbon monoxide can cause brain damage or death. Always read and understand instruction manual.	

Note: The actual firing rate of the water heater must not exceed the input rating on the water heater's rating label under any circumstances.

Note: Due to the input rating reduction at high altitudes, the output rating of the water heater is also reduced and should be compensated for in the sizing of the equipment.

TEMPERATURE REGULATION

HIGH TEMPERATURE LIMIT CONTROL (ECO)

This water heater is equipped with a non adjustable high temperature limit control.

The high temperature limit control sensors are located inside the Main Temperature Probe. See *Figure 5 (page 11)*, *Figure 6 (page 12)*, and *Figure 7 (page 13)* for location. The high temperature limit control activates when the water temperature reaches an unsafe level and deactivates when the water temperature falls back to a safe level.

If the high temperature limit control activates due to abnormally high water temperatures in the storage tank, the control system immediately deenergizes the gas valve and ends the current heating cycle. The control system becomes locked out, disabling further heating operation. The control system displays the "HIGH TEMP LIMIT EXCEEDED" fault message on the LCD screen. It is important that you contact a Qualified Service Agent to determine the reason for the high temperature limit control activation before resetting the high temperature limit control. Once the reason has been determined and corrected, the high temperature limit control can be reset as follows:

If the high temperature limit control activates, the water temperature must drop below 185°F (85°C) before the control system can be reset. Once the water temperature has cooled below this point, turn off the power supply to the water heater, then turn it on again to reset the control system

THERMOSTAT CONTROL

⚠ DANGER

Burn Hazard



Because of the increased risk from scalding, if you set the water heater's gas control knob higher than 120°F (49°C), install thermostatic point-of-use mixing valves at each point of use. Due to the increased risk of scalding, do not set the temperature of the thermostatic mixing valves above 120°F (49°C).

Hot water temperatures required for automatic dishwasher and laundry use can cause scald burns resulting in serious personal injury and/or death. *Table 22* shows the approximate time-to-burn relationship for normal adult skin.

The temperature at which injury occurs varies with the person's age and duration of exposure. The slower response time of children, the elderly, or disabled persons increases the hazards to them. If anyone using hot water provided by the water heater being installed fits into one of these groups or if there is a local code or state law requiring a certain water temperature at the point of use, then special precautions must be taken.

⚠ WARNING

Burn Hazard

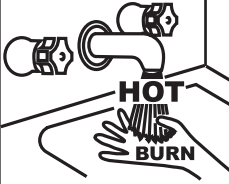

The temperature of the water in the water heater can exceed the thermostat setting and be hot enough to cause burns.

If you choose a higher temperature setting, install thermostatic mixing valves at each point-of-use to help avoid scalding.

In addition to using the lowest possible temperature setting that satisfies the demand of the application, a means, such as a thermostatic point-of-use mixing valve, for example, can be used at the hot water taps used by these people to reduce the water temperature.

Check State and/or local codes for thermostatic point-of-use mixing valve requirements and installation practices.

Never allow small children to use a hot water tap or draw their own bath water. Never leave a child or disabled person unattended in a bathtub or shower.

The water heater should be located in an area where the general public does not have access to set temperatures.

Setting the Operating Setpoint at 120°F will reduce risk of scalds. Some jurisdictions require settings at specific lower temperatures.

Table 22. Burn Time at Various Temperatures

Water Temperature °F (°C)	Time for 1st Degree Burn (Less Severe Burns)	Time for Permanent Burns 2nd & 3rd Degree (Most Severe Burns)
110 (43)	(normal shower temp.)	
116 (47)	(pain threshold)	
116 (47)	35 minutes	45 minutes
122 (50)	1 minute	5 minutes
131 (55)	5 seconds	25 seconds
140 (60)	2 seconds	5 seconds
149 (65)	1 second	2 seconds
154 (68)	instantaneous	1 second

(U.S. Government Memorandum, C.P.S.C., Peter L. Armstrong, Sept. 15, 1978)

⚠ WARNING

Burn Hazard

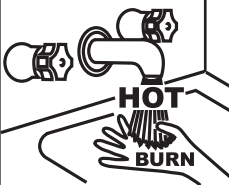

The temperature of the water in the water heater can exceed the thermostat setting and be hot enough to cause burns.

To reduce the risk of unusually hot water reaching the fixtures in the house, install point of use thermostatic mixing valves at each point of use.

The water heaters covered in this manual are equipped with an electronic control system to regulate the water temperature inside the storage tank. The control system senses the temperature from two factory-installed temperature probes: one installed in the top of the storage tank and the other installed near the bottom. See *Figure 5 (page 11)*, *Figure 6 (page 12)*, and *Figure 7 (page 13)* for location.

The Operating Setpoint is adjusted to regulate water temperature inside the storage tank. This is an adjustable user setting in the control system’s “Temperatures Menu.” This and all control system menus are accessed through the user interface module (UIM) located on the front of the water heater. See *Figure 79* (page 66).

The Operating Setpoint is adjustable from 90°F (32°C) to 180°F (82°C). The factory setting is 120°F (49°C). See *120°F (49°C)*. See *Operating Set Point and Differential Adjustment* (page 67) for instructions on how to adjust the Operating Set Point and other user settings.

Set the Operating Setpoint at the lowest setting which produces an acceptable hot water supply. This will always provide the most energy efficient operation.

Firing Rate Modulation

The water heaters covered by this manual are capable of modulating their firing rate. The controls system monitors the water temperature in the tank and regulates the firing rate to achieve the target temperature setpoint. The firing rate is dictated by the hot-water draw, proximity to the tank temperature and various other temperature limitations.

High Temperature Applications

Higher operating temperatures cause more wear on all water heaters and will decrease the life span of the water heater. Consider installing a small booster water heater for high temperature applications, such as commercial dishwashers, to raise the outlet temperature from the larger primary water heater to the desired point of use temperature.

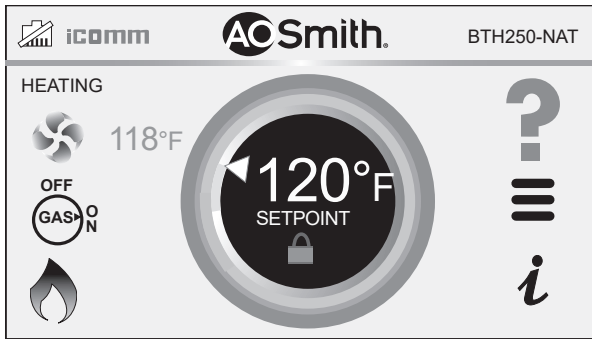
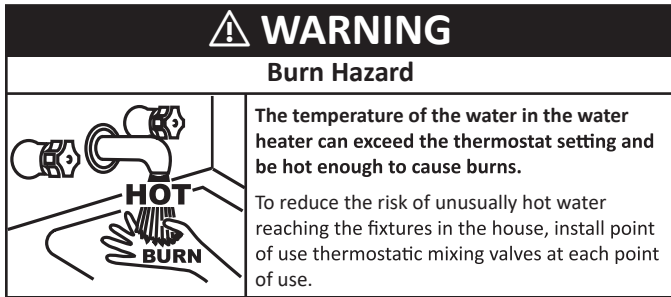

Figure 77. Tank Temperature Setpoint

CONTROL SYSTEM OPERATION

LIMITING THE RISK OF SCALDING

For a variety of reasons, water heaters can produce water that is much hotter than its temperature setting. Take precautions to prevent this higher temperature water from reaching the water fixtures.



According to a national standard, *Performance Requirements for Water Temperature Limiting Devices (ASSE 1070)* and many local plumbing codes, the water heater's gas control valve should not be used as the sole means to regulate water temperature and avoid scalds.

A properly adjusted thermostatic mixing valve at each point of use allows you to set the tank temperature to a higher setting without increasing risk of scalds. A higher temperature setting allows the tank to provide much more hot water and can help provide proper water temperatures for appliances such as dishwashers and washing machines.

WI-FI

The water heaters covered in this manual feature a Wi-Fi functionality that is enabled at the factory. If Wi-Fi is not required for installation, you can be disabled it as follows:

1. Go to main menu screen.
2. Select iCOMM icon.
3. Wi-Fi Status should show "AP Mode" (If not scroll down to "Change to AP Mode" line item and Enable).
4. Enable the Wi-Fi if it is showing as disabled.
5. Using a phone or tablet go to the Wi-Fi settings and search available networks.
6. In the list of networks, there should be a name that is similar to "iCOMMNextGenUIM-XXXXXXX". This is the website being broadcast by the display on the water heater. Select this network.
7. After selecting the iCOMM network, a separate message may appear asking for permission to Stay Connected to the selected network. Select the option to stay connected. Under the selected network name, there should be an indication that the Wi-Fi connected with the above iCOMM network.
8. Open a new Internet browser window on the device.
9. The Internet browser may automatically go to the web address 192.168.0.1. If it doesn't, type that number into the address bar. This will bring up a page that looks similar to the following:
10. Find the network name on the left that corresponds to the local Wi-Fi network, and select the Connect button to the right of it.
11. If the local network is password protected, a new screen will appear asking for the password. Enter the password for the local network and click Connect.

12. A confirmation message should appear indicating the Connection to Wi-Fi was completed.

LOCKOUT FUNCTION

The water heaters covered in this manual feature a lockout functionality that is disabled at the factory by default. If the lockout functionality is required by the end user, the initial installer/contractor can access this functionality and enable it through the UIM. See page 76 for the procedure.

CONTROL SYSTEM OVERVIEW

The water heaters covered in this manual are equipped with an electronic control system that regulates water temperature inside the storage tank. Heating cycles and ignition are managed by the control system. The high temperature limit control sensors, flame sensor, pressure switches, and temperature probes are monitored by the control system. The combustion blower, spark ignition transformer, gas valve and anode rods are all powered by the control system.

The main components of the control system are a user interface module (UIM), Temperature Regulation Control (TRC) and combustion safety control (CSC). The UIM is located on the top front side of the water heater. The control boards are mounted on top of the water heater inside a protective enclosure. This unit is equipped with an Enable/Disable switch. To operate unit, make sure the switch is set to Enable. See *Features and Components* (page 10) for location of these and all water heater components.

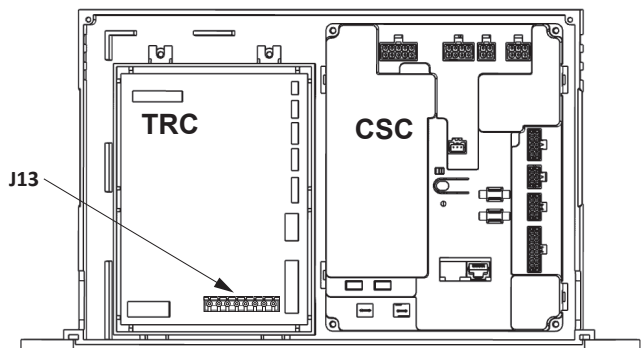

Figure 78. Control System Components

CONTROL SYSTEM NAVIGATION

All operational information and user settings are displayed and accessed from the UIM. The UIM houses the control system's LCD Touch Display (liquid crystal display).

The Home Screen

During normal operation, the control system displays the Home screen on the LCD Touch Display, which is the default screen. The control system returns to the Home screen when there are no active fault or alert conditions or when there has been no user input for several minutes.

- Manufacturer and water heater model information displays in the Title Bar at the top of the Home screen.
- The Operating setpoint is shown in the middle of the Home screen. This is the temperature at which the control system will maintain the water inside the storage tank.
- Status is shown in the upper left. The status shows the current

operational state of the control system in real time.

- The light green band on the temperature dial shows the temperature offset.
- The three horizontal lines on the Home screen will allow you to access sub menus.
- The Home screen also displays animated status icons to convey operational information. See Table 20 for descriptions of the status icons.

⚠ WARNING

Burn Hazard

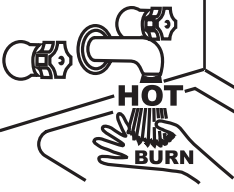

The temperature of the water in the water heater can exceed the thermostat setting and be hot enough to cause burns.

If you choose a higher temperature setting, install thermostatic mixing valves at each point-of-use to help avoid scalding.

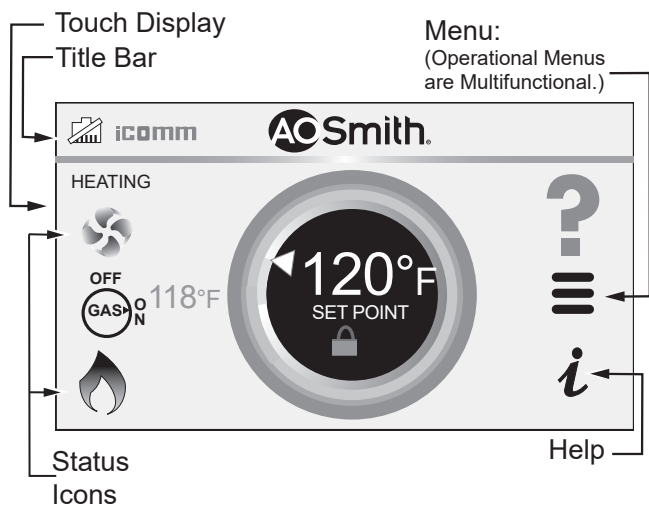

Touch Display
Title Bar

Menu:
(Operational Menus are Multifunctional.)





Status Icons

Help

Figure 79. User Interface Module (UIM) Home Screen

Status Icons

The Status Icons are displayed on the Home screen and convey operational and diagnostic information. The icons are described in the table below. See **Figure 79** (page 66). Ensure that the water heater is properly grounded. Proper operation requires an adequate earth ground. If the water heater is not properly grounded it will cause errors including Ignition Failure.

Table 23. Status Icons	
Icon	Description
	The Combustion Blower is energized.
	The gas valve is being energized.
	The control system has sensed flame at the Main Burner from the flame sensor. See Sequence of Operation (page 83) and Figure 2 (page 10).
	The control system has declared a fault condition and must be inspected/serviced by a Qualified Service Agent. Fault message details can be viewed in the Current Fault menu. Heating operation is disabled (lockout) until the condition that caused the fault is corrected. Power to the water heater must be cycled off and on at the breaker to reset the control system. Note: Cycling power will not reset the control system if the condition that caused the fault has not been corrected.
	The control system has declared an alert condition and must be inspected/serviced by a Qualified Service Agent. The water heater will continue to operate during an alert condition.

Operating States

The current operational state of the water heater is displayed on the Home screen as the "Status." The common operational states are described in the table below. See *Figure 79* (page 66).

Table 24. Operating States	
State	Description
Uncalibrated	The unit is currently uncalibrated and must go through calibration before use.
Calibration	The unit is currently going through calibration procedure.
Standby	Heater is waiting on a call for heat.
Initializing	The unit has begun a burn cycle and is checking all safety circuits.
Input Verification	The unit has begun a burn cycle and is checking all safety circuits.
Pre-Purge	The unit has begun a spark period to ignite the main burner.
Ignition	The unit has begun a burn cycle and is checking safety circuits.
Inter-Purge	After a failure to ignite the burner, the control is attempting to purge any excess gas from the heater exchanger before another attempt to light.
Heating	The water heater has been properly lit, and the water in the tank is being heated.
Post-Purge	Excess gas is being pushed out of the heater exchanger after a successful heating cycle.
System in Fault	The water heater control has detected a fault. No further heating of the water will be done until reset.
Blocked	A condition is preventing a burn cycle that must clear before resuming water heating.
Ext Ena	External enable/disable switch is active on unit.
BMS	BMS is active on unit.
Heater Disabled	The heater has been disabled and will not heat water.

Control System Menus

From the Home screen pressing "Menu" on the LCD Touch Display will display the "Main Menu" this is where all control system menus are located. The table below describes the control system menus.

Table 25. Control System Menu	
Menu	Description
Setpoint Manager	Most commonly accessed menu. Contains the Operating Set Point and Differential user settings.
Heater Status	This menu displays the current state of all pressure switches and the ECO. The on/off status of the Combustion Blower, gas valve, Spark Igniter, flame sensor and other monitored water heater components are displayed in this menu.
Display Settings	Temperature units (°F or °C), the LCD appearance (brightness/contrast) and back-light delay user adjustable settings are located in this menu.
Heater Information	Elapsed time of operation, total heating cycle time, heating cycle count, heating on time along with UIM and control board software revisions can be viewed in this menu.
Current Fault	Displays any current alert or fault messages.
Fault History	This control system menu retains a list of the last nine (9) fault and alert messages with a time stamp. The newest event will replace the oldest. Faults will clear after 30 days.
Fault Occurrence	This control system menu retains a running total of how many times each fault condition has occurred since the water heater was first installed. The data does not clear and cannot be reset.
Restore	This control system feature allows the user to restore control system user settings to their factory default settings. Display Settings preferences ARE NOT changed when factory defaults are restored.
Help Screens	Text based operational and user information explaining how to change user settings, navigate the control system menus and icon descriptions.

USER SETTINGS & CONTROL SYSTEM MENUS

Operating Set Point and Differential Adjustment

The Operating Setpoint is adjustable from 90°F (42°C) to 180°F (82°C). The factory setting is 120°F (49°C). The Differential is adjustable from 2°F (1°C) to 20°F (11°C). The factory setting is 8°F (4°C). These user settings are accessed from the Temperatures menu. The following instructions will explain how to adjust these settings and navigate the control system menus.

When the water temperature sensed by the control system from the two (main and lower) Temperature Probes reaches the Operating Setpoint the control system will end the heating cycle. A heating cycle will be activated again when the sensed water temperature drops below the Operating Setpoint minus the Differential setting.

⚠ **WARNING**

Burn Hazard

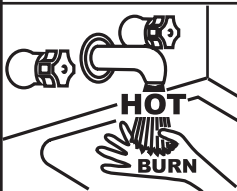

The temperature of the water in the water heater can exceed the thermostat setting and be hot enough to cause burns.

If you choose a higher temperature setting, install thermostatic mixing valves at each point-of-use to help avoid scalding.

Note: Lower Differential settings may cause excessive heating cycles (short-cycling) which can cause premature failure of heater components. Set the Differential at the highest setting which produces an acceptable hot water supply. Set the Operating Setpoint to the lowest setting which produces an acceptable hot water supply for most efficient use.

Setpoint Manager

From the Setpoint Manager, you can adjust the Differential Mode, the Differential, and see the current Tank Temperature.

To change the Operating Set-Point and Differential, do the following:

1. From the Home screen, press MENU icon. The “Main Menu” screen will be displayed.

Note: The differential is indicated by the light green band on the temperature dial.

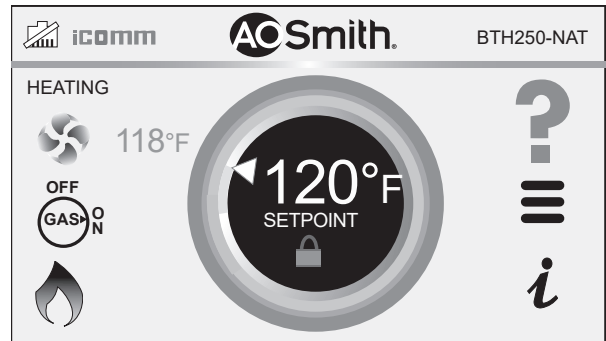

The Main Menu is where all control system menus are listed. See **Table 25 (page 67)** for a complete list and description of control system menus.

2. Press Heater icon to access the Setpoint Manager.

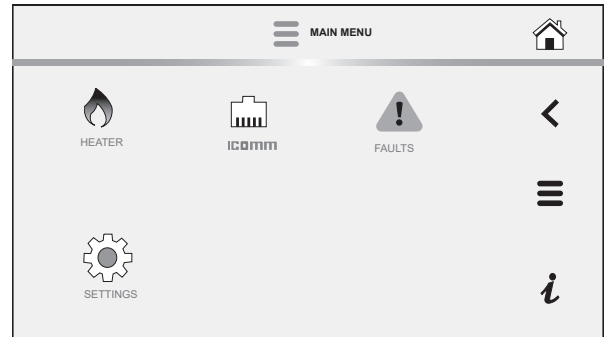

3. Use the arrow Buttons to change the current setting.

Note: Higher Temperature settings increase wear and operating costs. Set the Operating Setpoint to the lowest setting which produces an acceptable hot water supply. This will always provide the most energy efficient operation and longer life.

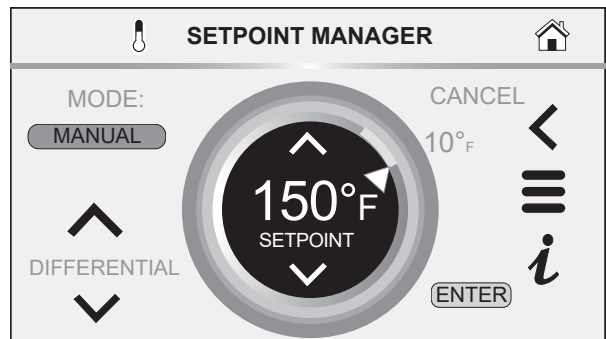

4. Tap “CONFIRM” to save the new setting. Press “CANCEL” to discard changes and return to the previously saved setting.

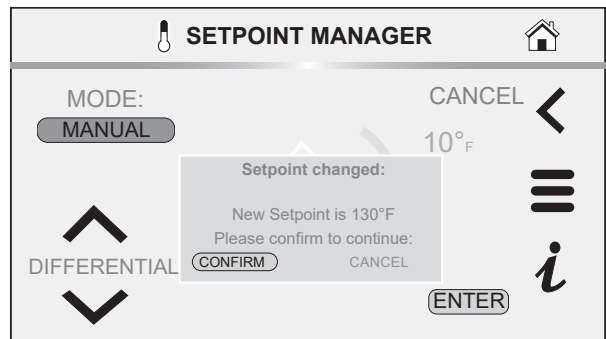

- To change the differential setting: change the mode from automatic to manual, then use the up and down arrows on the differential to change setting. Confirm to keep changes or Press the Cancel button to return to the previously saved settings.
 - Differential Mode** - Operating mode with an Intelligent Demand Response (IDR). This mode allows the water heater to reduce preset differential to a lower setting so that the appliance will more rapidly respond to large draws to maintain water outlet temperature. This mode is enabled at the factory by default, but can be disabled in the field if required.
 - Differential** - Adjustable user setting that changes the tank temperature differential with a range of 2° to 20°F. The factory setting is 8°F.
 - Tank Temperature** - Non adjustable. Control system sensed temperature (averaged from main and lower temperature probes).

These settings are adjusted in the same way described in *Operating Set Point and Differential Adjustment* (page 67).

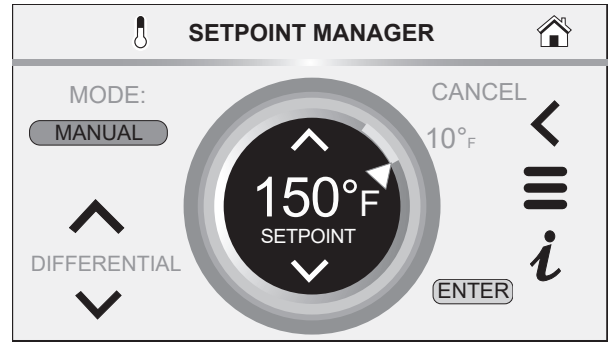

iCOMM Menu

- From the Home screen, press MENU icon. The “Main Menu” screen will be displayed.
- Press the iCOMM icon to access the iCOMM screen.

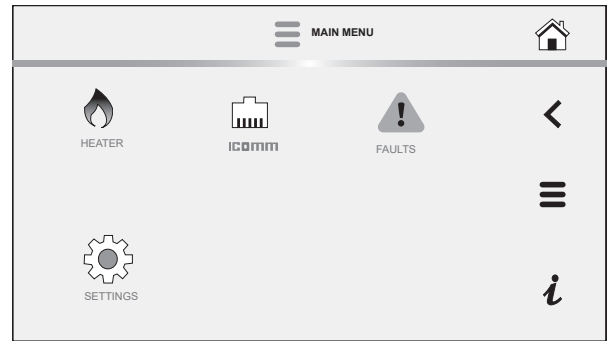

The iCOMM screen displays the following Wi-Fi information:

- Wi-Fi Status** - displays status of Wi-Fi connection.
- Ethernet** - displays status of Ethernet connection.
- iCOMM Server** - displays status the iCOMM server.
- Wi-Fi MAC** - displays the Wi-Fi MAC number.
- Ethernet MAC** - displays the Ethernet MAC number.
- DSN** - displays the Device Serial Number (DSN). Used for registration of the heater.
- Wi-Fi Strength** - displays Wi-Fi signal strength as a series of bars.
- Wi-Fi Strength** - displays Wi-Fi signal strength dBm units.

Wi-Fi - Wi-Fi functionality is enabled at the factory. In the bottom portion of the menu, the Wi-Fi can be disabled by selecting the **Enabled** marker and selecting the **Disable** option. This is the only item on this screen that can be adjusted. The other items are for view and information purposes only.

Top of menu

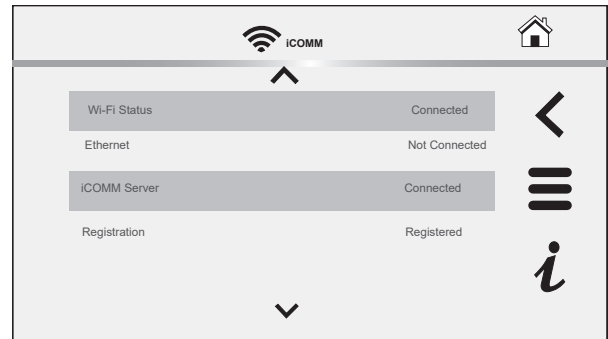

Bottom of Menu

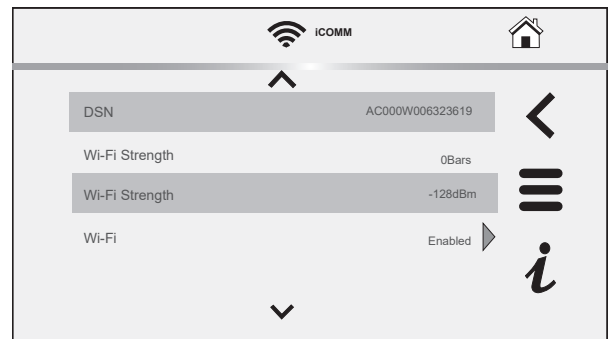

Heater Information Menu

- From the Home screen, press MENU icon.
The "Main Menu" screen will be displayed.
- From the Main Menu, press the Heater icon to access the Heater menu.

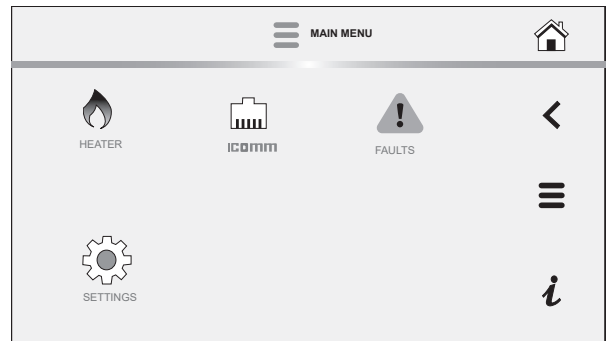

- Press the Heater Information icon from the Heater menu to enter the Heater Information screen.

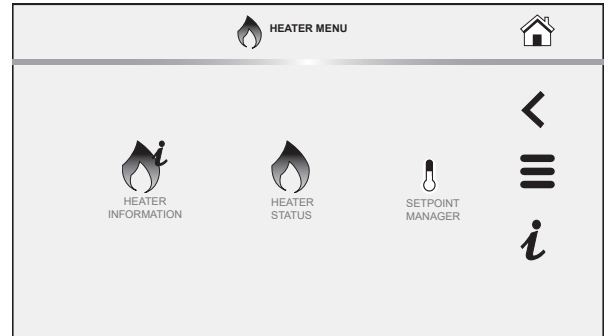

This screen contains non adjustable operational information.

- **Elapsed Time** - Total accumulated time the control system (water heater) has been energized.
- **Total Heat Time** - Total accumulated time the control system has been in the heating operating state; burner run time.
- **Total Cycle Counter** - Total accumulated count of heating cycles.
- **Ignition Failure Count** – Total accumulated count of ignition failures.
- **Flame Loss Count** - Total accumulated count of flame losses.
- **TRC Version** - Software version for TRC board.
- **UIM Version** - Software version for user interface module.
- **Serial Number** - Serial number of the water heater.
- **Model Number** - Model number of the water heater
- **CSC Version** - Software version for CSC board.
- **CPAM1 Version** - Software version for CPAM1.
- **CPAM2 Version** - Software version for CPAM2.
- **Building Management Version** - Software version for Building Management System.
- **Water Valve Control Version** - Software version for the water valve control.
- **NANODE Version** - Software version for NANODE.

Historical data is stored in the Flex Memory Module (FMM). If the FMM is removed or damaged during servicing, the historical data will be lost and heater may no longer operate. The FMM should never be replaced unless directed by Technical Support.

The Elapsed Time, Burner On Time and Cycle Count indicate age, usage and wear.

If the Cycle Count per day is high (divide cycle count by days to determine cycles per day) or the cycle duration is short (determine burner on time total minutes, divide burner on time total minutes by cycle count) consider raising the Differential setting to avoid short cycling and excessive component wear. See *Operating Set-Point and Differential Adjustment* (page 64).

This historical data can also be used to assist facilities managers in forecasting planned replacement of equipment to help avoid lengthy and costly hot water supply interruptions.

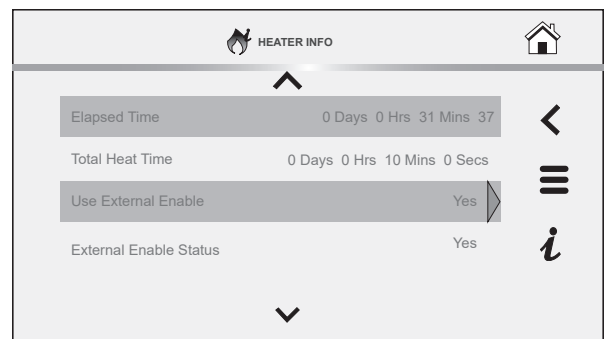

Heater Status Menu

1. From the Home screen, press MENU icon.
The "Main Menu" screen will be displayed.
2. From the Main Menu, press the **Heater Information** icon to access the Heater Information screen.

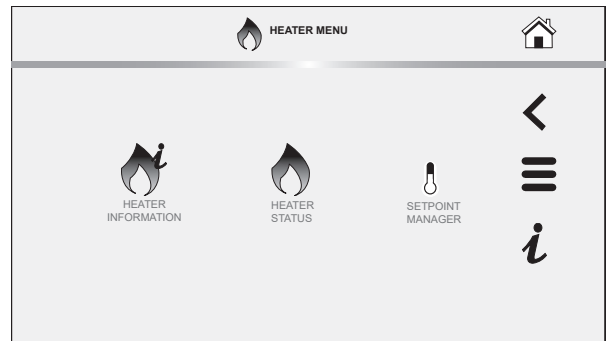

The Heater Status menu displays the following information:

- **Status** - Indicates whether the heater is Enabled or Disabled.
- **Blocked Inlet PS** - Indicates if the Inlet is blocked.
- **Blocked Outlet PS** - Indicates if the Outlet is blocked.
- **Igniter On** - Indicates if the Igniter is operational
- **Gas Valve On** - Indicates if the gas valve is on.
- **Flame Detected** - Indicates if flame is detected.
- **Blower RPM** - Indicates the blower RPMs
- **Main Temperature** - Temperature reading of the main temperature probe.
- **Lower Temperature** - Temperature reading of the lower temperature probe.
- **Anode Current** – Current reading of anode
- **Anode Tank Voltage** – Voltage of anode tank
- **Anode Drive Voltage** – Voltage of anode drive
- **Water Valve 1 Status** – Current status of Water Valve 1
- **Water Valve 1 Error** – Error in Water Valve 1
- **Water Valve 2 Status** - Current status of Water Valve 2
- **Water Valve 2 Error** - Error in Water Valve 2
- **Water Valve 3 Status** - Current status of Water Valve 3
- **Water Valve 3 Error** - Error in Water Valve 3

Top of Menu

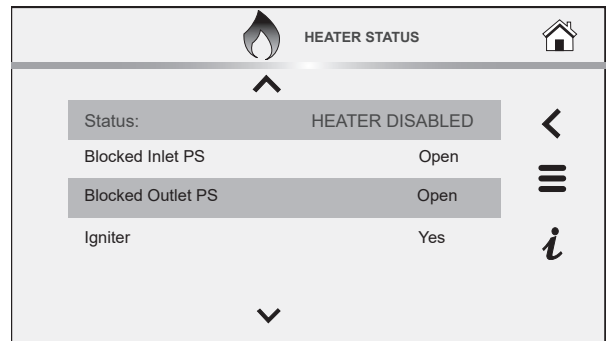

Bottom Of Menu

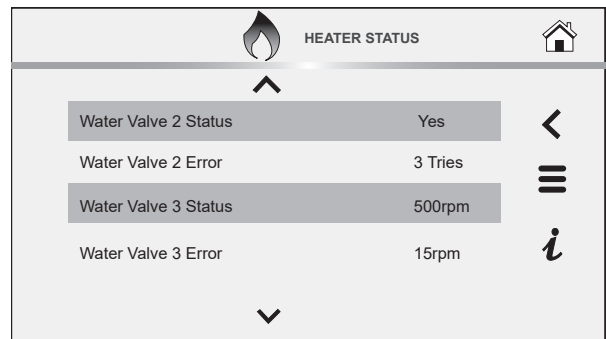

Display Settings Menu

1. From the Home screen, press MENU icon.
The "Main Menu" screen will be displayed.
2. From the Main Menu, press the Heater Information icon to access the Heater Information screen.

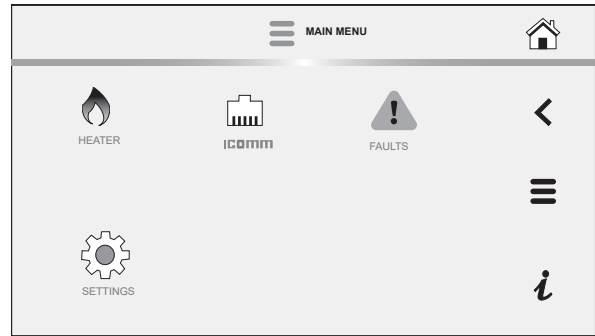

The Settings screen contains adjustable display options for viewing information on the LCD screen.

- **Temperature Units** - Adjustable user setting that changes temperature units display to Celsius °C or Fahrenheit °F.
- **Back-light Delay** - Adjustable user setting that determines how long the LCD back light remains illuminated after a key has been pressed. Available settings are; Always Off, 10, 30 or 60 seconds and Always On.
- **Brightness** - Adjustable user setting to adjust the LCD screen contrast between text and background.
- These settings are adjusted in the same way as described **Operating Set-Point and Differential Adjustment (page 64)**.
- **Lock Setpoint manager**
- **Current Date/Time**

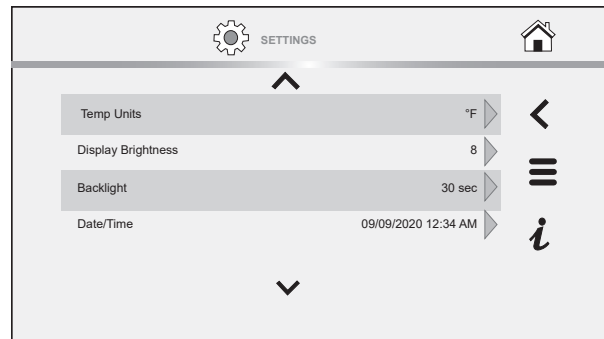

Current Fault

1. From the Home screen, press MENU icon.
The "Main Menu" screen will be displayed.
2. From the Main Menu, press the Faults icon to access the Fault Menu.

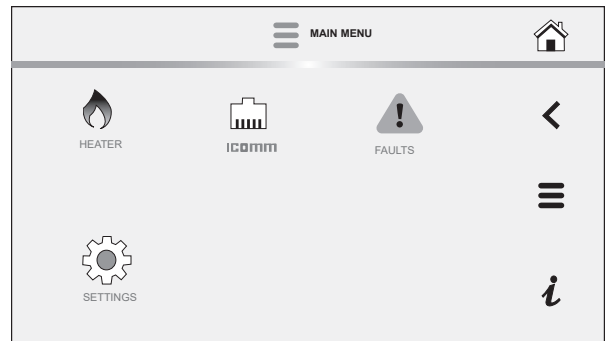

3. From the Fault Menu, press the Current Fault or Current Alert icon to access the Current Fault screen.

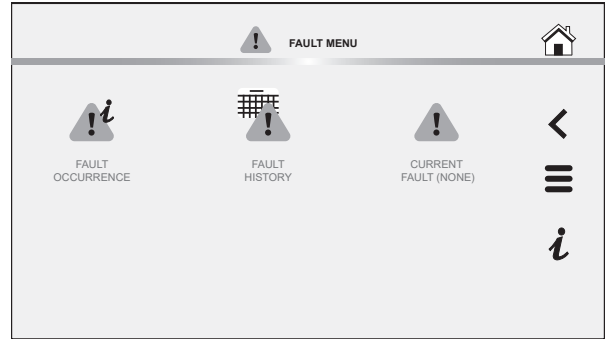

The Current Fault screen contains the current Fault or Alert error message. The time the Fault or Alert message occurred appears directly below. A brief description of what causes the particular Fault or Alert condition appears below that.

Press the MORE button for more detailed service information and a list of possible causes for the Fault or Alert condition.

See **Troubleshooting** (page 83) for more detailed information and diagnostic procedures.

If there is no Fault or Alert condition active this menu will not contain any information; "(none)" will be shown next to Current Fault in the Fault menu.

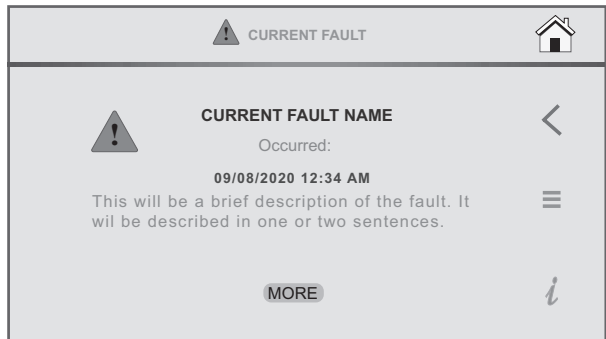

Fault History Menu

1. From the Home screen, press MENU icon.
The "Main Menu" screen will be displayed.
2. From the Main Menu, press the Faults icon to access the Fault Menu.

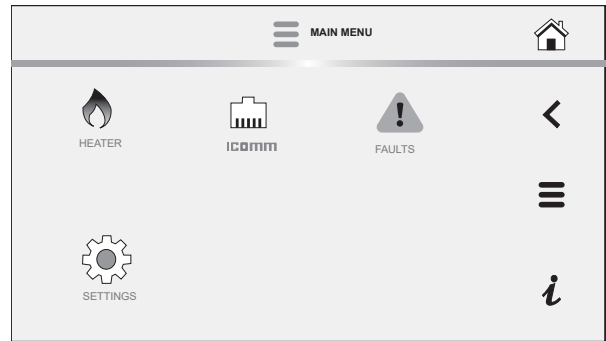

3. From the Fault Menu, press the Fault History icon to access the Fault History screen.
The Fault History screen contains non adjustable operational information.

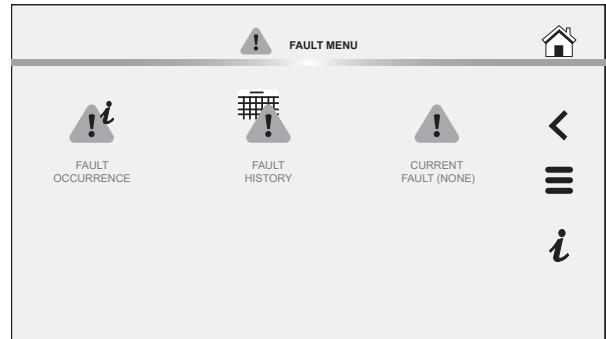

The Fault History screen contains a list of the last nine (9) Fault and Alert messages with a time stamp. The newest event will replace the oldest. Faults will clear after 30 days.

Press the Fault to view details for each Fault or Alert message stored.

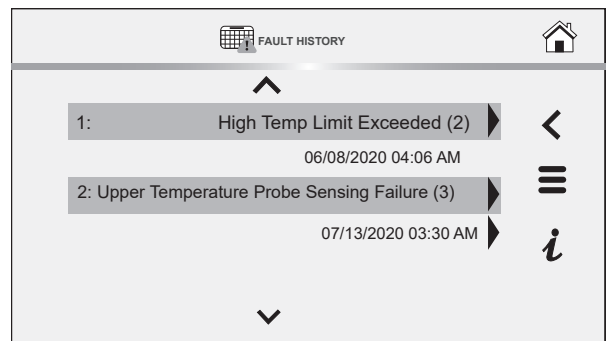

Fault Occurrence Menu

1. From the Home screen, press MENU icon.
The "Main Menu" screen will be displayed.
2. From the Main Menu, press the Faults icon to access the Fault Menu.

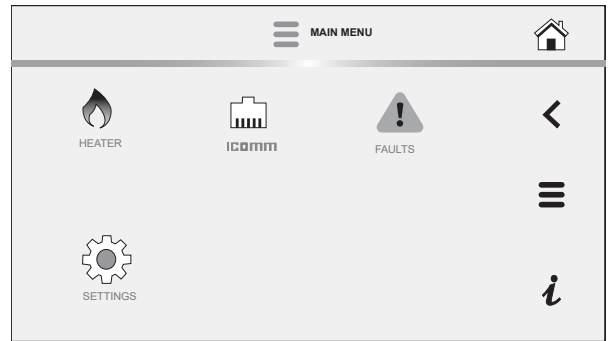

3. From the Fault Menu, press the Fault Occurrence icon to access the Fault Occurrence screen.
The Fault Occurrence screen contains a running total of how many times each Fault condition has occurred since the water heater was first installed.

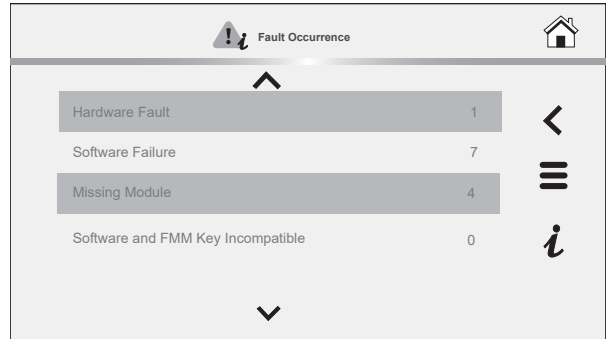

Lockout Function

1. From the Home screen, press MENU icon.
The "Main Menu" screen will be displayed.
2. From the Main Menu, press the Settings icon to access the Settings screen.
3. Use the arrow buttons to scroll through the list to the Lock item.
4. Click on the arrow to the right to access the Lock dialog box.

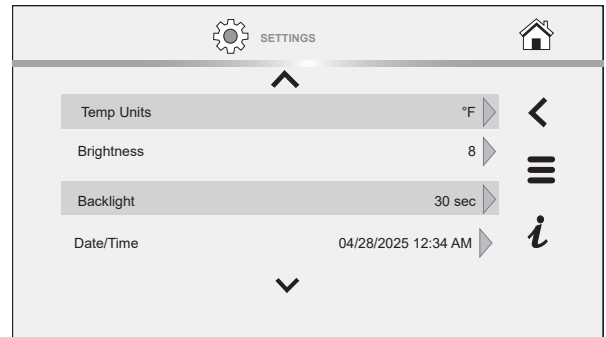
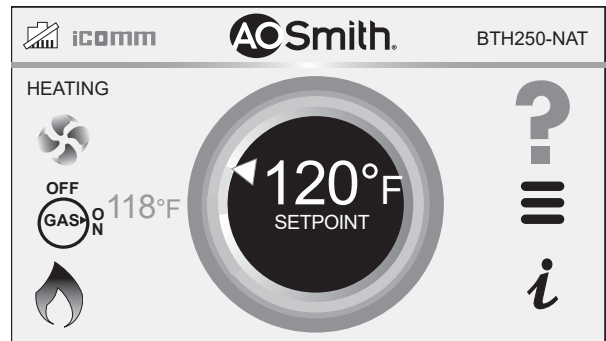

5. Use the arrows in the Lock dialog box to toggle Yes to enable the lock or No to disable the lock.

Note: The lock is disabled by default from the factory.

Click Confirm to implement your selection.



6. Press and hold on the lock icon on the Home screen to unlock the Setpoint settings.

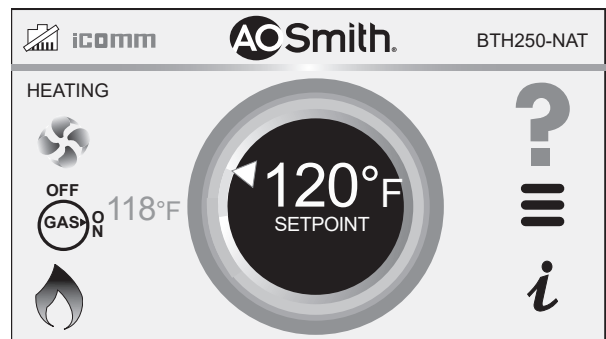

Restore Factory Defaults Function

1. Press and hold on the A. O. Smith logo on the Home screen.
The Service Information screen displays.

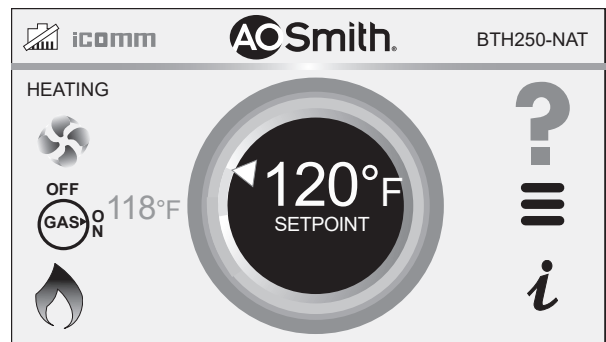

2. Select Restore User Defaults on the Service Information screen.

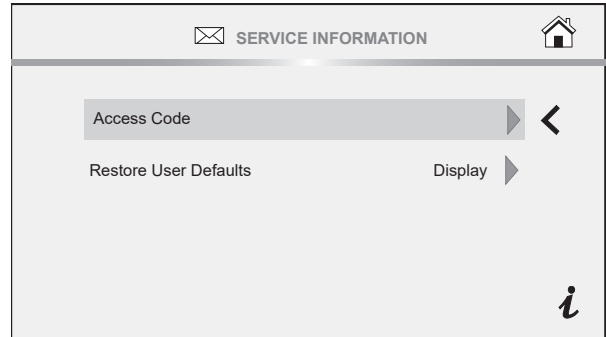

3. Ensure TRC is selected in the list menu, then press the Confirm buttons.
The original factory settings of the water heater are restored.

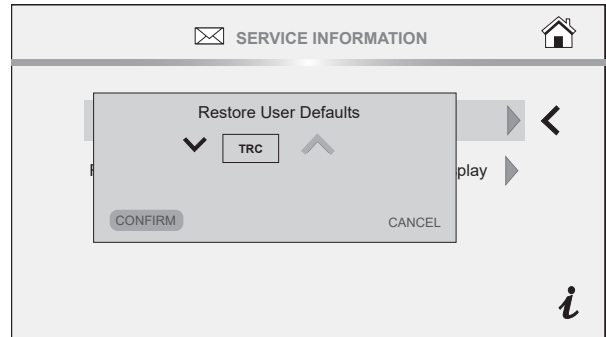

Service Contact Information

The control system has a menu that Installing contractors and/or service agents can access to enter their contact information for customers. This contact information will be displayed with all Fault and Alert messages.

1. From the Home screen, press the Main Menu icon. The Main Menu screen displays.
2. From the Main Menu screen, press the Settings icon.

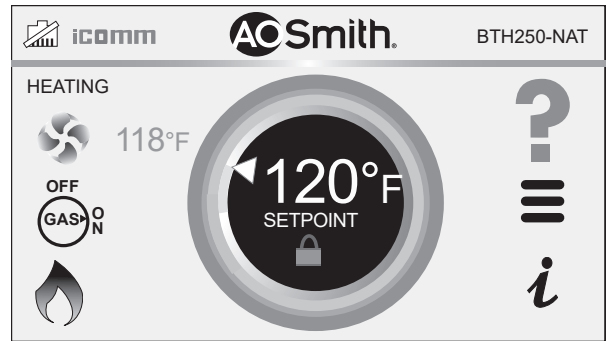

3. Scroll down to the Settings Menu and select the Current Contact Info item. The Contact Information screen displays.

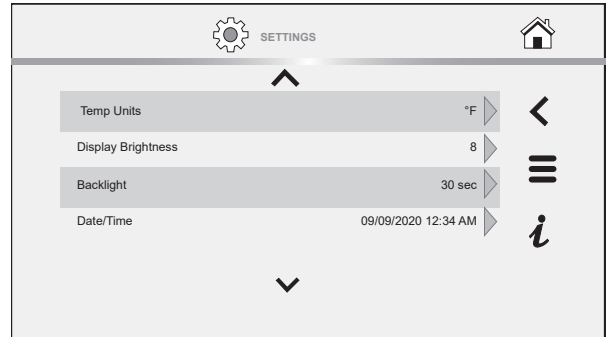

4. To edit a contact information item, select it and press the Pencil icon.
5. Edit the item using the keyboard. Press the Save Key to save your data after each entry.

Note: You can enable or disable the display of Contact info by editing the "Show Contact" item on the Settings Menu.

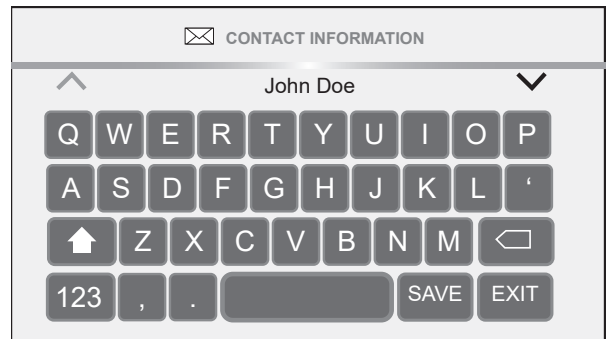

MAINTENANCE

Water heater maintenance includes periodic tank flushing and cleaning, and removal of lime scale. The water heater should be inspected and adjusted to maintain proper combustion. See **Start Up** (page 56). A periodic inspection of the venting system should be made. Where used, water circulating pump(s) should be oiled according to the pump manufacturers recommendations.

MAINTENANCE SCHEDULE

Table 26. Maintenance Schedule			
Component	Operation	Interval	Reference
Tank	Drain and Flush	Every 6 Months	See <i>Maintenance</i> (page 79).
Tank	Lime Scale Removal (Water Less Than 25 Grains Hard)	Not Required	N/A
Tank	Lime Scale Removal (Water Greater Than 25 Grains Hard)	Annually	See <i>Lime Scale Removal</i> (page 80).
Burner Flames	Inspection	Every 3 Months	See <i>Burner Flame Inspection</i> (page 81).
Burner	Inspection/Cleaning	As Needed	Contact qualified agency or professional.
Moving Parts	Lubrication	Not Required	N/A
Powered Anodes	Inspection/Cleaning	Annually	See <i>Anode Rod Maintenance</i> (page 81).
T&P Valve	Test Operation	Semi Annually	See <i>Temperature-Pressure Relief Valve Test</i> (page 82).
Vent System	Inspection	Annually	See <i>Vent System Maintenance</i> (page 82).
Condensate Neutralization	Inspection	Annually	See manual for the condensate neutralization kit.
Condensate Collection	Cleaning	Annually	See <i>Vent System Maintenance</i> (page 82).

Precautions

⚠ CAUTION

Safety Hazard

Do not operate the water heater if it has been exposed to or exhibits the following:

- Exposed to flooding or water damage
- External damage.
- Firing without water.
- Sooting.

Do not operate the water heater until all corrective steps have been made by a qualified service technician.

Never operate the water heater without first being certain it is filled with water and a properly sized and rated Temperature-Pressure Relief Valve is installed in the relief valve opening on the water heater. See *Temperature-Pressure Relief Valve* (page 22).

⚠ WARNING

Explosion Hazard



- Overheated water can cause water tank explosion.
- A properly sized temperature and pressure relief valve must be installed in the opening provided.

If overheating occurs or the gas supply fails to shut off, turn off the Main Gas Shutoff valve. See *Figure 69* (page 51).

DRAINING AND FLUSHING

It is recommended that the water heater storage tank be drained and flushed every 6 months to reduce sediment buildup. The water heater should be drained if being shut down during freezing temperatures. See *Features and Components* (page 10) for the location of the water heater components described below.

⚠ DANGER

Burn Hazard



The discharge water from the drain valve is hot enough to cause burns.

Keep your hands clear of the drain valve discharge outlet.

Draining the Water Heater Storage Tank

1. Turn the Enable/Disable switch located on the front of the heater to the Disabled position.
2. Turn off the electrical supply to the water heater.
3. Turn off the gas supply at the Main Gas Shutoff Valve if the water heater is going to be shut down for an extended period.
4. Ensure that the cold water inlet valve is open.
5. Open a nearby hot water faucet and let the water run until the water is no longer hot.
6. Connect a hose to the water heater drain valve and terminate it to an adequate drain.
7. Close the cold water inlet valve.
8. Open the water heater drain valve and allow all the water to drain from the storage tank.
9. Close the water heater drain valve when all water in the storage tank has drained.
10. Close the hot water faucet opened in Step 4.
11. If the water heater is going to be shut down for an extended period, the drain valve should be left open.

Flushing the Water Heater Storage Tank

1. Turn the Enable/Disable switch located on the front of the heater to the Disabled position.
2. Turn off the electrical supply to the water heater.
3. Ensure that the cold water inlet valve is open.
4. Open a nearby hot water faucet and let the water run until the water is no longer hot. Then close the hot water faucet.
5. Connect a hose to the drain valve and terminate it to an adequate drain.
6. Ensure that the drain hose is secured before and during the entire flushing procedure. Flushing is performed with system water pressure applied to the water heater.
7. Open the water heater drain valve to flush the storage tank.

8. Flush the water heater storage tank to remove sediment and allow the water to flow until it runs clean.
9. Close the water heater drain valve when flushing is completed.
10. Remove the drain hose.
11. Fill the water heater. See **Filling The Water Heater** (page 56).
12. Turn on the electrical supply to place the water heater back in operation.
13. Allow the water heater to complete several heating cycles to ensure it is operating properly.

SEDIMENT REMOVAL

Waterborne impurities consist of the particles of soil and sand which settle out and form a layer of sediment on the bottom of the tank.

For convenience, sediment removal and lime scale removal should be performed at the same time.

LIME SCALE REMOVAL

When water is heated dissolved minerals in the water such as calcium and magnesium carbonate (lime scale) become less soluble. As the water temperature rises these minerals will precipitate or “fall out” of solution.

The amount of lime scale released from water is in direct proportion to water temperature and usage. The higher the water temperature or water usage, the more lime deposits are dropped out of the water.

Water hardness also affects lime scale accumulation. With the temperature and usage being the same, hard water will release more lime scale than softer water.

Lime scale reduces heating efficiency as it accumulates inside a water heater. Heating transfer surfaces become coated with lime scale deposits which increases fuel costs to operate the water heater. Lime scale deposits can also cause rumbling and pounding noises as air molecules trapped in the lime scale escape when heated. Lime scale accumulation also reduces the life span of water heaters. For these reasons a regular schedule for deliming should be set up.

The depth of lime accumulation in the bottom of the water heater should be measured periodically. Inspect by removing the clean-out cover once every 6 months at first. Deliming maintenance should then be performed based on the time it takes for 1 inch (2.5 cm) of lime to accumulate in the bottom of the water heater.

Sediment and lime scale removal may be accomplished manually through the clean-out opening furnished on the water heater. See **Figure 80**.

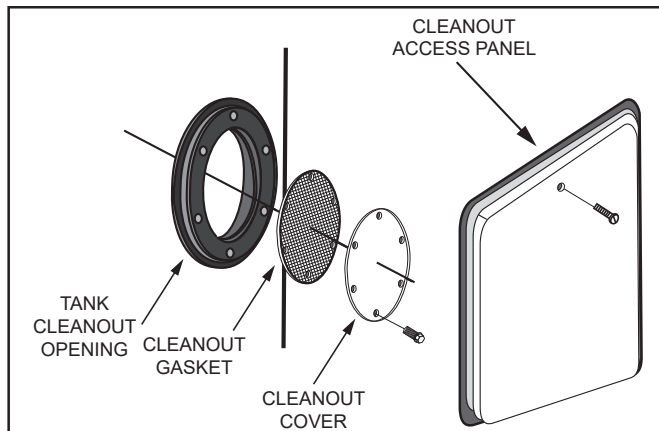

Figure 80. Clean-out Access

Manual Lime Scale Removal

Note: Contact Technical Support for assistance in ordering a new clean-out gasket. See the contact information label on the water heater. Have the new gasket available before removing the clean-out cover.

The cleanout opening is shown in **Figure 80**. To remove lime scale manually through the clean-out opening proceed as follows:

1. Turn off the electrical supply to the water heater.
2. The water heater must be drained. See (page 79). Follow the instructions on how to drain the water heater.
3. Remove outer clean-out access panel from lower side of the water heater jacket.
4. Remove the clean-out cover from clean-out opening.
5. Remove lime, scale and/or sediment using care not to damage the glass-lining.
6. Install a new clean-out gasket if required.
7. Reinstall the clean-out cover. Be sure to draw plate up tight by tightening screws securely.
8. Close the water heater drain valve.
9. Fill the water heater. See **Filling The Water Heater** (page 56).
10. Turn on the electrical supply to place the water heater back in operation. See **Start Up** (page 56).
11. Allow the water heater to complete several heating cycles to ensure it is operating properly.
12. Check for water leakage.
13. Reinstall the clean-out access panel.

Chemical Lime Scale Removal

To dissolve and remove more stubborn lime scale deposits, white vinegar should be used. Hydrochloric base acids must not be used to delime the water heaters covered in this manual.

BURNER FLAME INSPECTION

Check main burner every three months for proper flame characteristics. You can see the burner flame through the sight glass on top of the burner plate. To access the sight glass, you must remove the plastic cover.

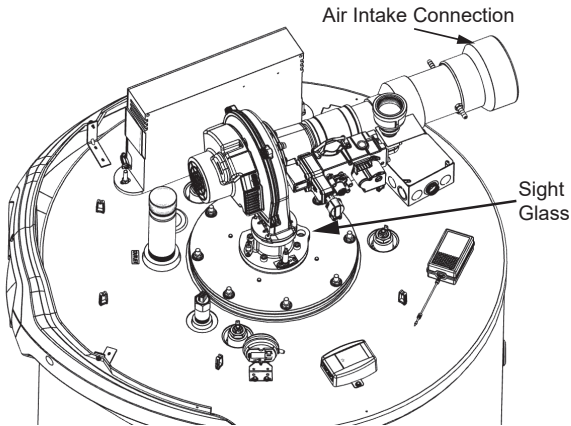

Figure 81. Location of Sight Glass

The main burner should display the following characteristics:

- Provide complete combustion of gas.
- Cause rapid ignition and carry over of flame across entire burner.
- Give reasonably quiet operation during initial ignition, operation and extinction.
- Cause no excessive lifting of flame from burner ports. See Figure 82.

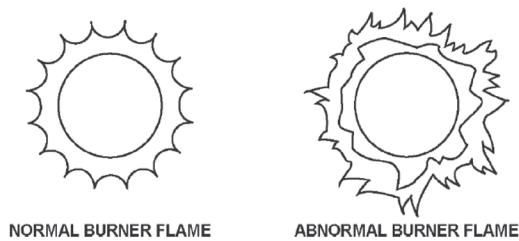

Figure 82. Normal and Abnormal Burner Flames

If the preceding burner characteristics are not evident, check for accumulation of lint or other foreign material that restricts or blocks the air intake fitting or air intake terminal.

To ensure continued good performance, keep the area around the water heater clean and free from lint and debris. Sweep the floor around the water heater regularly. This will reduce the dust and dirt which can enter the burner and heat exchanger, causing improper combustion and sooting.

If the air intake fitting and air intake terminal are clear and the burner continues to exhibit abnormal flames, contact a qualified service agency or have a qualified service professional inspect and clean the burner.

ANODE ROD MAINTENANCE

CAUTION

Property Damage Hazard

	Operating the water heater with depleted or malfunctioning anodes can damage the water heater. Annual inspection and replacement of the anode rod is required.
---	--

The water heaters covered in this manual are factory equipped with powered anode rods mounted in the top of the unit. The anode rods are of a permanent design and do not need replacing unless damaged, however, inspection and cleaning should be performed once a year.

To inspect the powered anode, do the following:

1. Turn off electrical supply and gas supply to the water heater.
 2. Shut off the water supply and open a nearby hot water faucet to depressurize the water tank.
 3. Drain approximately 5 gallons of water from tank. See (page 79) for proper procedures. Close drain valve.
 4. Remove the wiring connection on the top of the powered anode.
 5. Remove the powered anode by loosening the 3/4" NPT bushing that forms the top of the anodes.
 6. Remove the entire anode rod from the water heater for inspection.
 - If undamaged and in working order, clean the anode rod with a soft cloth and reinstall.
 - If the anode needs to be replaced, obtain a new anode rod. Apply thread-sealer[®] tape or an approved pipe sealant on the threads before installing the new powered anode rod.
- Whether re-installing or replacing the powered anode rod, check for any leaks and immediately correct if found.
7. Turn on water supply and open nearby hot water faucet to purge air from water system.
 8. Refill the water heater following the instructions for *Filling The Water Heater* (page 56).
 9. Restart the water heater as directed in this manual.

DRAIN VALVE AND ACCESS PANELS

The water heaters covered in this manual are equipped with a drain valve. See *Features and Components* (page 10) for location. The water heaters covered in this manual are also equipped with a clean-out opening for sediment and lime scale removal. See Figure 80 (page 80).

TEMPERATURE-PRESSURE RELIEF VALVE TEST

⚠ DANGER	
Burn Hazard	
	<p>The discharge water from the temperature-pressure relief valve is hot enough to cause burns.</p> <p>Keep clear of the temperature-pressure relief valve discharge outlet.</p>

It is recommended that the Temperature-Pressure Relief Valve should be checked to ensure that it is in operating condition every 6 months.

When checking the Temperature-Pressure Relief Valve operation, make sure that (1) no one is in front of or around the outlet of the Temperature-Pressure Relief Valve discharge line, and (2) that the water discharge will not cause any property damage, as the water may be extremely hot. Use care when operating valve as the valve may be hot.

To check the relief valve, lift the lever at the end of the valve several times. See *Figure 83*. The valve should seat properly and operate freely.

If after manually operating the valve, it fails to completely reset and continues to release water, immediately close the cold water inlet to the water heater and drain the water heater. See *Draining and Flushing* (page 79). Replace the Temperature-Pressure Relief Valve with a properly rated/sized new one. See *Temperature-Pressure Relief Valve* (page 22) for instructions on replacement.

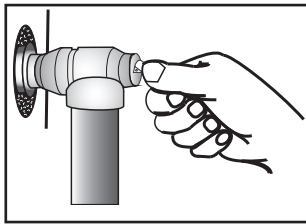

Figure 83. Testing the T&P Relief Valve

If the Temperature-Pressure Relief Valve on the water heater weeps or discharges periodically, this may be due to thermal expansion.

Note: Excessive water pressure is the most common cause of Temperature-Pressure Relief Valve leakage. Excessive water system pressure is most often caused by “thermal expansion” in a “closed system.” See *Closed Water Systems* (page 22) and *Thermal Expansion* (page 22). The Temperature-Pressure Relief Valve is not intended for the constant relief of thermal expansion.

Temperature-Pressure Relief Valve leakage due to pressure build up in a closed system that does not have a thermal expansion tank installed is not covered under the limited warranty. Thermal expansion tanks must be installed on all closed water systems.

Do not plug the Temperature-Pressure Relief Valve opening. This can cause property damage, serious injury or death.

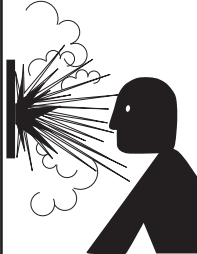
⚠ WARNING	
Explosion Hazard	
	<p>Normal operation of the water heater can cause it to become sufficiently over-heated and/or over-pressurized that it can explode, resulting in property damage, sever injury, or death.</p> <p>To avoid this hazard, you must install a properly-sized temperature-pressure relief valve in opening provided.</p> <ul style="list-style-type: none">• The temperature-pressure relief valve must comply with ANSI Z21.22-CSA 4.4 and ASME code.• Do not plug, block, or cap the discharge line.

VENT SYSTEM MAINTENANCE

Examine the vent system once a year. Points of inspection are as follows:

1. Check for obstructions and/or deterioration of the intake-air and/or vent piping and the intake-air and vent terminations. Replace immediately where needed.
2. The debris screens in the intake-air and vent terminations should be cleaned of foreign material and soot. See *Figure 38* (page 38).

Note: Do not reach inside the vent termination when the heater is in operation.

3. Check all vent system connections for leakage and repair or reseal as necessary.

TROUBLESHOOTING

INSTALLATION CHECKLIST

The list below represents some of the most critical installation requirements that, when overlooked, often result in operational problems, down time and needless parts replacement. This is not a complete list. Before performing any troubleshooting procedures use the list below to check for installation errors.

Note: Costs to correct installation errors are not covered under the limited warranty. Ensure that all installation requirements and instructions in this manual have been maintained and followed.

Water Heater Location

1. Ensure proper clearances to combustibles are maintained and there is sufficient room to service the water heater. See *Clearance to Combustible Materials* (page 19).
2. Ensure that the area is free of corrosive elements and flammable materials. See the instructions in *Contaminated Air* (page 25).

Venting

3. Ensure that the intake-air and/or vent (exhaust) piping is the correct size for the installed length. See (page 31).
4. Ensure that the maximum equivalent length of pipe has not been exceeded for the intake-air and/or vent pipe. See *Table 7* (page 32).
5. Ensure that the maximum number of elbows has not been exceeded in the intake-air and/or vent pipe. See (page 31).
6. Ensure that the intake-air screen is removed from the intake-air connection on the water heater when installing the water heater in a Direct Vent configuration. See *Figure 34* (page 36).
7. Ensure that all exterior clearances for the intake-air, vent, concentric, and low profile terminations are maintained. See *Vertical Termination Installation* (page 36), *Sidewall Termination Installation* (page 38), *Low Profile Vent Installation* (page 44). These clearances and those cited by local and national codes must be maintained.

Gas Supply And Piping

8. Ensure a supply gas regulator has been installed for each water heater.
9. Ensure that the supply gas line to each water heater meets the minimum supply gas line size requirements. See the requirements for the supply gas line in *Table 4* (page 18) and *Table 5* (page 18) and the instructions in *Supply Gas Line Installation* (page 51).

Condensate Drain

10. Ensure that the condensate drain is properly connected to the exhaust elbow on the water heater with a water trap to prevent vent gases from escaping into the installed space and draining freely to a suitable floor drain. See *Figure 15* (page 24) and *Condensate Drain Installation* (page 50).

Electrical Connections

11. Ensure that the power supply is on a dedicated circuit and connections to the water heater are polarity correct. See the requirements for the *Power Supply* (page 21) and *Electrical Wiring* (page 53).
12. Ensure that the water heater is properly grounded. Flame sensing requires an adequate earth ground. If the water heater is not properly grounded it will cause Ignition Failure.

SEQUENCE OF OPERATION

Read the Sequence of Operation before attempting to correct any operational problems. See *Features and Components* (page 10) for the location of various water heater components described below. See *Sequence of Operation* (page 84).

1. When the control system is first powered, during boot up, it will display water heater model information during initialization. After a few moments the control system LCD which is part of the user interface module (UIM) will display the default screen known as the Home screen.
2. If the control system determines that the actual water temperature inside the tank is below the programmed Operating Setpoint minus the Differential setting, a heating cycle is activated.
3. The control system then performs selected diagnostic system checks. This includes confirming the blocked exhaust, blocked intake and high temperature limit control sensors are not activated.
4. If all diagnostic checks are successfully passed, the control system energizes the Combustion Blower for prepurge.
5. The control system energizes the spark ignition control.
6. The control system energizes the Gas Valve allowing gas to flow to the Main Burner.
7. The control system monitors the flame sensor to confirm a flame is present at the Main Burner. If a flame is not verified during the ignition trial period the control system will try for ignition up to two more times. If flame can not be verified after three trials for ignition, the control system will lockout and display the "Ignition Failure" fault message.
8. If a flame is verified, the control system will deenergize the Spark Ignition Control and enter the heating mode where it will continue heating the water until the Operating Setpoint is reached. At this point, the control system will deenergize the Gas Valve and enter the post-purge cycle.
9. The water heaters covered by this manual are capable of modulating their firing rate. The firing rate is dictated by the hot water draw and various other temperature limitations.
10. The Combustion Blower will run for the duration of the post-purge cycle to purge the water heater of all combustion gases. When the post-purge cycle is complete, the blower is deenergized and will coast to a stop.
11. The control system now enters the standby mode while continuing to monitor the internal storage tank water temperature and the state of other system devices. If the tank temperature drops below the Operating Setpoint minus the Differential setting, the control will automatically return to Step 2 and repeat the operating cycle.

Sequence is shown with Enable/Disable Switch in the Enable position

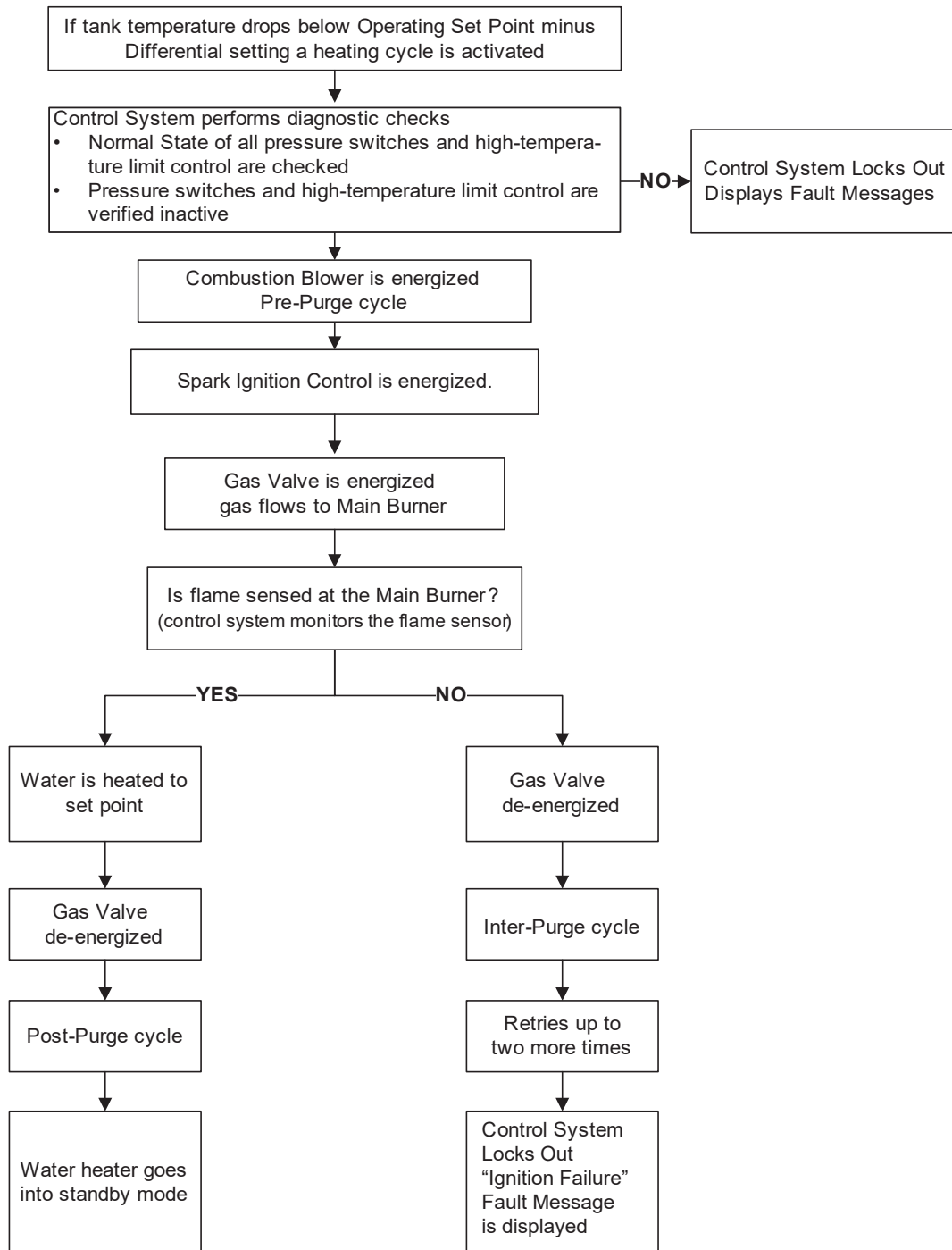



Figure 84. Sequence of Operation

OPERATIONAL PROBLEMS

 WARNING	
Safety Hazard	
	<p>Failure to follow these instructions and safety messages could result in death or serious injury.</p> <p>Read and understand this instruction manual and the safety messages herein before installing, operating or servicing this water heater.</p> <p>This manual must remain with the water heater.</p>

This section of the manual is intended to be an aid in correcting common operational problems, it is not all inclusive. The installer may be able to observe and correct certain problems which might arise when the water heater is first put into operation or when it is re-fired after a prolonged shutdown. However, only qualified service agents, as defined in **Qualifications** (page 8), using appropriate test equipment, should perform any service procedures on the water heater.

Note: Contact Technical Support for assistance in locating a qualified service agent in your area. See the contact information label on the water heater.



Installation Errors

Operational problems on new installations are often the result of installation requirements that have been overlooked rather than failed components. Rough starting and rough operation are often caused by undersized supply gas lines and/or the absence of a supply gas regulator at the water heater.

Prior to performing any operational checks, inspect the water heater installation to ensure that all installation requirements and instructions have been maintained and followed. See **Installation Checklist** (page 83).

Note: Costs to correct installation errors are not covered under the limited warranty.

Rough Starting, Rough Operation

 WARNING	
Fire and Explosion Hazard	
	<ul style="list-style-type: none">• Do not use water heater with any gas other than the gas shown on the rating label.• Excessive gas pressure to gas valve can cause serious injury or death.• Turn off gas lines during installation.• Contact a qualified installer or service agency for installation and service.

- Undersized supply gas line (low volume of supply gas). See

the requirements for the supply gas line in **Table 4** (page 18) and **Table 5** (page 18) and the instructions in **Supply Gas Line Installation** (page 51).

- Supply gas regulator is not installed per installation requirements (erratic gas supply volume/pressures). See **Supply Gas Regulator** (page 21).
- Excessive supply gas pressure. See **Table 5** (page 18) and **Supply Gas Regulator** (page 21).
- Vent (exhaust) gas recirculation at the vent and intake-air pipe terminations on direct vent installations. See **Direct Vent Installation** (page 35).
- Excessive equivalent lengths of intake-air and/or vent (exhaust) piping installed. See (page 31).
- Debris clogging/blocking the intake-air screen(s). See **Figure 33** (page 36) and **Figure 38** (page 38).
- Debris clogging/blocking the Main Burner. See **Figure 2** (page 10).

Momentary Ignition

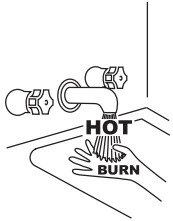
 CAUTION	
Burn Hazard	
	<ul style="list-style-type: none">• The combustion chamber and burner sleeve and housing become very hot during operation.• Do not reach into the burner housing or combustion chamber if the water heater is still hot.• Allow the water heater to cool and always use gloves when handling the main burner.

If the Main Burner ignites momentarily but does not sustain ignition allow the water heater to try to ignite up to two more times until control system locks out and the Ignition Failure Fault message is displayed on the control system's LCD. If the water heater is experiencing rough starts. See **Rough Starting, Rough Operation** on this page. For momentary ignition problems without rough starting check the following:

- Undersized supply gas line (low volume of supply gas). See the requirements for the supply gas line in **Table 4** (page 18) and **Table 5** (page 18) and the instructions in **Supply Gas Line Installation** (page 51).
- Supply gas regulator is not installed per installation requirements (erratic gas supply volume/pressures). See **Supply Gas Regulator** (page 21).
- See the list of possible causes and things to check and repair for the Ignition Failure Fault message in **Fault and Alert Messages** (page 87).
- Debris clogging/blocking the intake-air screen(s). See **Figure 33** (page 36) and **Figure 38** (page 38).
- Debris clogging/blocking the Main Burner **Figure 2** (page 10).

Not Enough Or No Hot Water

- No power to the water heater, check breaker or fuses.
- Enable/Disable switch in “Disabled” position. Set to “Enable” to allow unit to operate.
- Hot water supply valve(s) to fixtures closed.
- Operating Set Point is set too low, Differential setting is set too high. See *Control System Operation* (page 65).
- Tank Probe Offset is causing the heating cycles to terminate prematurely. See *Setpoint Manager* (page 68).
- The heating capacity of the water heater has been exceeded, the water heater is unable to meet demand.
- Colder incoming water temperature lengthening the time required to heat water to desired temperature.
- Hot water piping leaks, open faucets, water heater drain valve leaking or open.
- Sediment or lime scale accumulation may be affecting water heater operation. See *Maintenance* (page 79) for sediment and lime scale removal procedures.
- Water heater not firing at full input rating. See *Checking the Firing Rate* (page 61).

Note: The water heaters covered by this manual are capable of modulating their firing rate. The firing rate is dictated by the hot water draw and various other temperature limitations.

Water Is Too Hot

- Operating Set Point is set too high. See *Operating Set Point and Differential Adjustment* (page 67).
- If installed check Thermostatic Mixing Valve settings.
- Tank Probe Offset setting improperly set. See *Setpoint Manager* (page 68).
- Lime build-up on temperature probes. Inspect and clean.
- Improper water piping. See *Water Piping Diagrams* (page 105).

Noisy Operation

- Sediment or lime scale accumulations can cause rumbling and pounding noises during heating cycles. See *Maintenance* (page 79) for sediment and lime scale removal procedures.
- Normal operating noise of electrical components; Combustion Blower, transformer hum, relay contact closure.

Water Leakage Is Suspected

- Ensure that the water heater drain valve is tightly closed.
- Check cleanout opening for leaks. See *Figure 8* (page 14) *Figure 9* (page 14).
- Check inlet/outlet water connections and system piping.
- Check the Temperature-Pressure Relief Valve.
 - Excessive water temperature.
 - Excessive water pressure.
 - Defective Temperature-Pressure Relief Valve.

Note: Excessive water pressure is the most common cause of Temperature-Pressure Relief Valve leakage. Excessive water system pressure is most often caused by “thermal expansion” in a “closed system.” See *Closed Water Systems* (page 22) and *Thermal Expansion* (page 22). The Temperature-Pressure Relief Valve is not intended for the constant relief of thermal expansion.

Temperature-Pressure Relief Valve leakage due to pressure build up in a closed system that does not have a thermal expansion

tank installed is not covered under the limited warranty. Thermal expansion tanks must be installed on all closed water systems.

Replacement Parts

Replacement parts may be ordered from the manufacturer, authorized service agencies or distributors. When ordering parts be sure to have the complete water heater Model Number, Serial Number and Series Number available. This information can be found on the rating label affixed to the water heater.

See the parts list included with the water heater from the factory for more information or contact Technical Support for assistance. See the contact information label on the water heater.

FAULT AND ALERT CONDITIONS

Fault Conditions

When the control system declares a Fault condition it will display a Fault message on the control system’s LCD with an exclamation “!” mark. The control system will lock out and disable heating operation until the condition is corrected. The water heater must be serviced by a qualified service agent before operation can be restored.

Alert Conditions

When the control system declares an Alert condition it will display an Alert message on the control system’s LCD with a question “?” mark. The water heater will continue to operate during an Alert condition but the water heater must be serviced by a qualified service agent as soon as possible.

Resetting Control System Lock Outs

To reset the control system from a lock out condition; turn the electrical power supply off for approximately 20 seconds and then back on. Keep in mind; if the condition that caused the Fault has not been corrected, the control system will continue to lock out.

Diagnostic Checks

⚠ WARNING	
Electrical Shock Hazard	
	<p>Servicing this water heater exposes you to electrified components that can cause severe injury or death if you touch them.</p> <ul style="list-style-type: none">• Turn off power at the branch circuit breaker serving the water heater before performing any service.• Label all wires prior to disconnecting when performing service. Wiring errors can cause improper and dangerous operation.• Verify proper operation after servicing.

The following section, Fault And Alert Messages on page 60 and 61, lists some of the messages the control system will display on the LCD when there are operational problems. This is not a complete list. Along with each of the Fault and Alert messages described there will be a list of possible causes and things to check and repair.

Only qualified service agents, as defined in Qualifications on page 6, using appropriate test equipment, should perform any service procedures on the water heater.

Note: If you are not qualified and licensed or certified as required by the authority having jurisdiction to perform a given task do not attempt to perform any of the diagnostic or service procedures described in the following section.

If you do not understand the instructions in the following section do not attempt to perform any procedures.

Contact Technical Support for assistance in locating a qualified service agent in your area. See the contact information label on the water heater.

WARNING	
Safety Hazard	
	<p>Jumping out control circuits or components can result in property damage, personal injury or death.</p> <ul style="list-style-type: none"> • Service should only be performed by a qualified service technician using proper test equipment. • Altering the water heater controls and/or wiring in any way could result in permanent damage to the controls or water heater and is not covered under the limited warranty. • Any bypass or alteration of the water heater controls and/or wiring will result in voiding the appliance warranty.

FAULT AND ALERT CONDITIONS

Fault Conditions

When the control system shows a Fault condition it will display a Fault message on the control system's UIM with an exclamation "!" mark. The control system will lockout and disable heating operation. To reset the current fault, toggle the Enable/Disable switch on the front of the heater from enable to disable, and then back to enable. If the condition that caused the fault has not been resolved the fault will reappear. The water heater must be serviced by a qualified service agent before operation can be restored.

Alert Conditions

When the control system declares an Alert condition it will display an Alert message on the control system's LCD with a question "?" mark. The water heater will continue to operate during an Alert condition but the water heater must be serviced by a qualified service agent as soon as possible.

Verify the power to the water heater is turned off before performing any service procedures. The Enable/Disable switch on front panel disables the gas valve. Electrical supply must be turned off at circuit breaker serving water heater.



Fault and Alert Messages

Contact Technical Support for further assistance or to locate a qualified service agent in your area. See the contact-information label on the water heater.

Fault and Alert Messages		
FAULT CODE	Possible Causes - Check/Repair	Displayed Fault/Alert Message
<p>2</p> <p>Data Error Code: (3, 30) NTC A short (3, 31) NTC A open (3, 32) NTC B short (3, 33) NTC B open (3,1001) NTC C open (3,1002) NTC C short (3,1018) NTC drift</p>	<p>High Temp Limit Exceeded</p> <p>The water heater is shut down due to high tank temperature.</p> <p>The water temperature in the tank has exceeded the high temperature limit.</p> <ol style="list-style-type: none"> 1. Use a thermometer at a hot water fixture to confirm the actual water temperature. If temperature is below 180° reset water heater. 2. If problem continues, contact technical support or refer to the service handbook for further instructions. 	
<p>3</p> <p>Data Error Code: 30;31; 32;33</p>	<p>Main Temperature Probe Failure</p> <p>The indicated temperature probe might be shorted or open.</p> <p>The control system has detected an issue with the main temperature probe.</p> <ol style="list-style-type: none"> 1. Ensure the wire connections for the main temp probe are clean and secure. 2. Ensure the wire harness for the main temp probe is free from damages. 3. If the problem continues, contact technical support or refer to the service handbook for further instructions. <p>Note: If there are both main and lower temperature probes, the Main Temperature probe is the main temperature probe.</p>	

Fault and Alert Messages		
FAULT CODE	Possible Causes - Check/Repair	Displayed Fault/Alert Message
<p>4</p> <p>Data Error Code: (4,1006) NTC open (4,1007) NTC short</p>	<p>Lower Temperature Probe Failure</p> <p>The indicated temperature probe might be shorted or open.</p> <p>The control system has detected an issue with the main temperature probe.</p> <ol style="list-style-type: none"> 1. Ensure the wire connections for the lower temp probe are clean and secure. 2. Ensure the wire harness for the lower temp probe is free from damages. 3. If the problem continues, contact technical support or refer to the service handbook for further instructions. 	
<p>5</p> <p>Data Error Code: (3,10xx) where xx = 5,9,13 or 17</p>	<p>Software Failure</p> <p>Internal control failures are detected on TRC. Cycle power to the water heater.</p> <p>The controls system has detected a software issue.</p> <ol style="list-style-type: none"> 1. Cycle the main power supply to the water heater by turning off the breaker/disconnect, then wait approximately 30 seconds and turn main power supply back on. 2. If problem continues, contact Technical Support or refer to the service handbook for further instructions. 	
<p>6</p> <p>(6,10xx) where xx = 4, 8, 12 or 16</p> <p>OR</p> <p>(6,80xx) where xx = 1-10</p>	<p>Hardware Failure</p> <p>Internal control failures are detected on the TRC. Cycle power to the water heater.</p> <p>The controls system has detected a hardware issue.</p> <ol style="list-style-type: none"> 1. Cycle the main power supply to the water heater by turning off the breaker/disconnect, then wait approximately 30 seconds and turn main power supply back on. 2. If problem continues, contact Technical Support or refer to the service handbook for further instructions. 	
<p>9</p> <p>Data Error Code: 22</p>	<p>Power Supply Fault</p> <p>The Control System is detecting a problem with the incoming power supply.</p> <ol style="list-style-type: none"> 1. Cycle the main power supply to the heater by turning off the breaker/disconnect, then wait approximately 30 seconds and turn main power supply back on. 2. If problem continues, contact technical support or refer to the service handbook for further instructions. 	

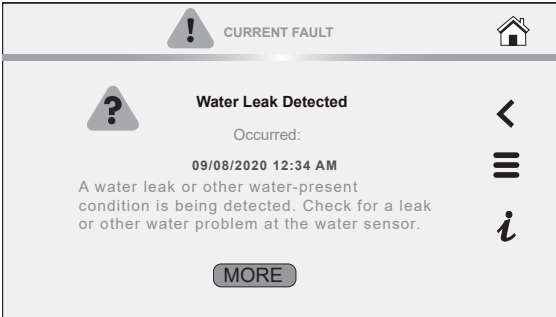
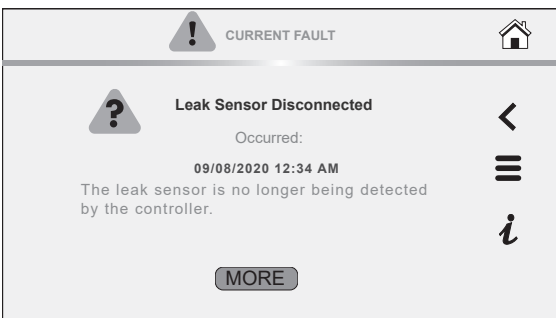
Fault and Alert Messages		
FAULT CODE	Possible Causes - Check/Repair	Displayed Fault/Alert Message
20 Data Error Code: (20,0)	<p>Communication Failure</p> <p>Communications between the display and the TRC is lost.</p> <p>The control system has lost communications with UIM.</p> <ol style="list-style-type: none"> 1. Cycle the main power supply to the heater by turning off the breaker/disconnect, then wait approximately 30 seconds and turn main power supply back on. 2. Inspect the communication cable between the UIM and the TRC to ensure the cable is not damaged and the connections are clean and secure. 3. If problem continues, contact technical support, or refer to the service handbook for further instructions. 	
25 Data Error Code: (4,1010) NTC open (4,1011) NTC short	<p>Flue Gas Temperature Probe Failure</p> <p>The flue gas temperature probe might be shorted or open.</p> <p>The control system has detected an issue with the flue gas temperature probe.</p> <ol style="list-style-type: none"> 1. Cycle the main power supply to the heater by turning off the breaker/disconnect, then wait approximately 30 seconds and turn main power supply back on. 2. If problem continues, contact technical support for further instructions. 	
26 Data Error Code: (4,1014) NTC open (4,1015) NTC short	<p>Recirc Temperature Probe Failure</p> <p>The recirculation temperature probe might be shorted or open.</p> <p>The control system has detected an issue with the recirc temperature probe.</p> <ol style="list-style-type: none"> 1. Cycle the main power supply to the heater by turning off the breaker/disconnect, then wait approximately 30 seconds and turn main power supply back on. 2. If problem continues, contact technical support for further instructions. 	

Fault and Alert Messages		
FAULT CODE	Possible Causes - Check/Repair	Displayed Fault/Alert Message
31 Data Error Code: (31,7002) or (31, 7003) or (31, 7004)	<p>Water Leak Detected</p> <p>A water leak or other water-present condition is being detected. Check for a leak or other water problem at the water sensor.</p> <p>The control system has detected a leak near the heater.</p> <ol style="list-style-type: none"> 1. Inspect the area around the heater for signs of moisture. 2. Inspect all threaded fittings connected to the water heater for signs of moisture. 3. Inspect the exhaust elbow connection to the heater for signs of moisture. 4. Inspect the cleanout cover for signs of moisture. 5. Using litmus strips for pH testing to identify if the moisture is condensate or water from the tank. 6. Condensation from the exhaust will be highly acidic. 7. If problem continues, contact technical support for further instructions. 	
32 Data Error Code: (32, 7001))	<p>Leak Sensor Disconnected</p> <p>The leak sensor is no longer being detected by the controller.</p> <p>The control system has detected that the leak detector has been disconnected.</p> <ol style="list-style-type: none"> 1. Ensure the leak detector is securely connected to the water heater. 2. Ensure the leak detector harness is securely connected to the TRC at terminal J6 pins 1 and 11. 3. If problem continues, contact technical support for further instructions. 	
33 Data Error Code: (33, 60x7) where x = 0 is on TRC-1000 board anode circuit x = 1 is CPAM 1, x = 2 is CPAM 2 etc.	<p>Anode Shorted</p> <p>The powered anode is shorted to earth ground or to the tank.</p> <p>The Control System has detected that the anode rod has shortage to the tank.</p> <ol style="list-style-type: none"> 1. Inspect anode wire connection for corrosion, moisture, or other contaminates. 2. Ensure wire connection on both ends is secure. 3. Ensure anode wire harness is not damaged. 4. If problem continues, contact technical support for further instructions. 	

Fault and Alert Messages		
FAULT CODE	Possible Causes - Check/Repair	Displayed Fault/Alert Message
<p>34</p> <p>Data Error Code: (34, 60x4) where x = 0 is on TRC-1000 board anode circuit. x = 1 is CPAM 1, x = 2 is CPAM 2 etc.</p>	<p>No Water</p> <p>No water is detected by the powered anode.</p> <p>The Control System is not detecting water in the tank.</p> <ol style="list-style-type: none"> 1. Ensure there is water in the tank by following Fill the Tank Instructions found in the installation manual. 2. Inspect anode wire connection for corrosion, moisture, or other contaminates. 3. Ensure wire connection on both ends is secure. 4. Ensure anode wire harness is not damaged. 5. If problem continues, contact technical support for further instructions. 	
<p>36</p> <p>Data Error Code: 244 (36, 2440x) where x = 1 to 9 are reason codes.</p>	<p>Weak Flame Signal</p> <p>The Combustion Safety Control (CSC) is detecting low-flame generated current.</p> <p>The control system has detected a weak flame signal</p> <ol style="list-style-type: none"> 1. Ensure that the flame sensor wire harness is free of damages 2. Ensure that the flame sensor wire connection on both ends is secure and free of contaminates 3. Remove flame sensor and inspect for contaminates or damages in ceramic insulator 4. Clean flame sensor rod with steel wool 5. If the problem continues, contact technical support, or refer to the service handbook for further instructions 	
<p>37</p> <p>Data Error Code: 2, 130 (37, 2) Or (37, 130)</p>	<p>Flame Sensor Error</p> <p>The control system has detected a flame sensor error.</p> <p>The flame-sense rod is detecting a flame signal when the gas valve is supposed to be off.</p> <p>The control system has detected a flame sensor error.</p> <ol style="list-style-type: none"> 1. Ensure that the flame sensor wire harness is free of damages. 2. Ensure that the flame sensor wire connection on both ends is secure and free of contaminates. 3. Remove flame sensor and inspect for contaminates or damages in ceramic insulator. 4. Clean flame sensor rod with steel wool. 5. If the problem continues, contact technical support, or refer to the service handbook for further instructions. 	

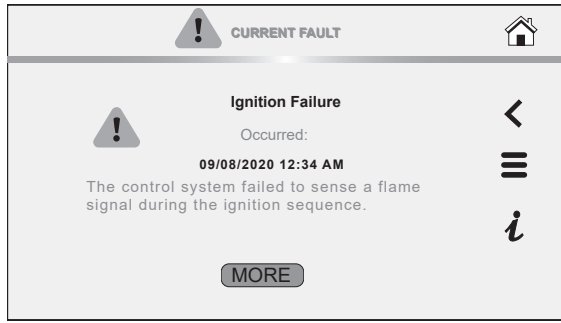
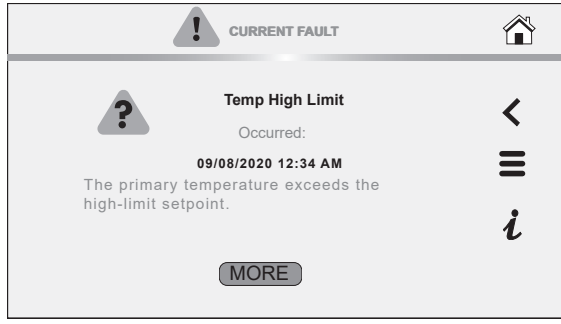
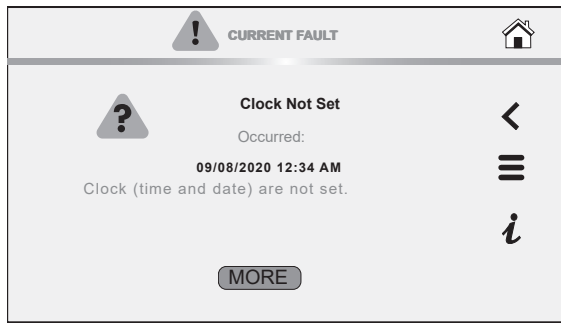
Fault and Alert Messages		
FAULT CODE	Possible Causes - Check/Repair	Displayed Fault/Alert Message
38 (Resideo 129, 147, 241) or 38 Data Error Code: (38, 129) or (38, 147) or (38, 241) or (38, 38)	<p>Ignition Failure</p> <p>The control system failed to sense a flame signal during the ignition sequence.</p> <p>The control system failed to sense a flame signal during the ignition sequence</p> <ol style="list-style-type: none"> Verify that the gas supply, venting, and intake air pipes are installed according to the instruction manual provided with the water heater. If the problem continues, contact technical support, or refer to the service handbook for further instructions. 	 <p>The screenshot shows a 'CURRENT FAULT' notification for 'Ignition Failure'. It includes a warning icon, the title 'Ignition Failure', the occurrence time '09/08/2020 12:34 AM', and the description: 'The control system failed to sense a flame signal during the ignition sequence.' There is a 'MORE' button and navigation icons (back, menu, info, home).</p>
41 Data Error Code: (41, 1003)	<p>High Temperature Warning</p> <p>The main temperature probe exceeds 190°F.</p> <p>The water temperature in the tank has exceeded the high temperature warning temperature. The warning will reset when tank temperature drops below 180°F.</p> <ol style="list-style-type: none"> Reset the water heater by toggling the Enable/Disable switch to disable and back to enable. If the problem continues, use a thermometer at a hot water fixture to confirm the water temperature. If the problem continues, contact technical support or refer to the service handbook for further instructions. 	 <p>The screenshot shows a 'CURRENT FAULT' notification for 'Temp High Limit'. It includes a warning icon with a question mark, the title 'Temp High Limit', the occurrence time '09/08/2020 12:34 AM', and the description: 'The primary temperature exceeds the high-limit setpoint.' There is a 'MORE' button and navigation icons (back, menu, info, home).</p>
42	<p>Clock Not Set</p> <p>Clock (time and date) are not set.</p> <p>Check the iComm connection (if equipped) and reconnect for automatic calendar updates.</p> <p>The control system recognized that the clock is not set.</p> <ol style="list-style-type: none"> Refer to the installation manual for instructions on how to set the clock. If the problem continues, contact technical support for further instructions. 	 <p>The screenshot shows a 'CURRENT FAULT' notification for 'Clock Not Set'. It includes a warning icon with a question mark, the title 'Clock Not Set', the occurrence time '09/08/2020 12:34 AM', and the description: 'Clock (time and date) are not set.' There is a 'MORE' button and navigation icons (back, menu, info, home).</p>

Fault and Alert Messages		
FAULT CODE	Possible Causes - Check/Repair	Displayed Fault/Alert Message
201 Data Error Code: 71 (201, 71)	<p>Blocked Air Intake</p> <p>There is a restriction in the air intake. Check the intake pipe and termination for blockage.</p> <p>The control system has detected a blockage in the intake air pipe.</p> <ol style="list-style-type: none"> 1. Ensure that the intake air pipe installed according to the manufacturer's installation manual. 2. Ensure that all horizontal pipe runs are properly sloped to prevent moisture from accumulating and restricting air flow. 3. Inspect the inside of the intake air pipe from the connection at the blower, all the way to the outside termination for restrictions. 4. Inspect the plastic sensing tube to the blocked intake air pressure switch to ensure there are no restrictions. 5. Ensure the blocked intake air pressure switch wires are free from damages and contaminates. 6. Ensure wire connections are secure and free from contaminates. 7. If problem continues, contact technical support, or refer to the service handbook for further instructions. 	
202 Data Error Code: 70 (202, 70)	<p>Blocked Exhaust</p> <p>There is a restriction in exhaust pipe. Check exhaust pipe and termination for blockage.</p> <p>The control system has detected a blockage in the exhaust vent pipe.</p> <ol style="list-style-type: none"> 1. Ensure that the exhaust vent pipe installed according to the manufacturer's installation manual. 2. Ensure that all horizontal pipe runs are properly sloped to prevent moisture from accumulating and restricting air flow. 3. Inspect the inside of the exhaust vent pipe from the water heater connection all the way to the outside termination for restrictions. 4. Inspect the plastic sensing tube to the blocked exhaust pressure switch to ensure there are no restrictions. 5. Ensure the blocked exhaust pressure switch wires are free from damages and contaminates. 6. Ensure wire connections are secure and free from contaminates. 7. If problem continues, contact technical support, or refer to the service handbook for further instructions. 	

Fault and Alert Messages		
FAULT CODE	Possible Causes - Check/Repair	Displayed Fault/Alert Message
205 Data Error Code: (205,200x) Where: x =2 if the key is uninitialized x=3 if key configuration is corrupt.	<p>Software and FMM Incompatible</p> <p>The TRC version is older than the TRC version stored in key.</p> <p>The control system has detected a device that is incompatible.</p> <ol style="list-style-type: none"> Contact Technical Support for further instructions. 	
206 Data Error Code: (206, 2011)	<p>CPAM Disconnected</p> <p>Communication with the anode module has been lost.</p> <p>The control system has detected that the CPAM is disconnected.</p> <ol style="list-style-type: none"> Ensure CPAM is powered Ensure wire connections are secure and free of contaminates Ensure wire harness is free of damages If problem continues, contact technical support or refer to the service handbook for further instructions 	
207 Data Error Code: (207, 35)	<p>CSC Disconnected</p> <p>Communication with the Combustion Safety control (CSC) has been lost.</p> <p>The CSC is disconnected.</p> <ol style="list-style-type: none"> Ensure the communication cable is securely connected between the TRC on terminal J4 and the CSC on terminal X10. If problem continues, contact technical support or refer to the service handbook for further instructions. 	
209 Data Error Code: (209, 2013)	<p>Water Valve Module Disconnected</p> <p>Communication with the water valve module has been lost.</p> <p>The control system has detected that the Valve Module is disconnected.</p> <ol style="list-style-type: none"> Ensure Valve module is powered. Ensure wire connections are secure and free of contaminates. Ensure wire harness is free of damages. If problem continues, contact technical support or refer to the service handbook for further instructions. 	

Fault and Alert Messages		
FAULT CODE	Possible Causes - Check/Repair	Displayed Fault/Alert Message
210 Data Error Code: (210, 35)	<p>Auto Test Complete</p> <p>Cycle Main Power to water heater. If problem continues, contact technical support for further instructions.</p>	
211 Data Error Code: (211, 133)	<p>No Blower Speed Feedback</p> <p>The control system has not detected the correct feedback from the blower when a command was sent to the blower to operate.</p> <ol style="list-style-type: none"> 1. Ensure both wire connections to the blower and to the control system is secure and free of contaminates. 2. Ensure the wire harnesses are free from damages. 3. If problem continue, contact technical support, or refer to the service handbook for further instructions. 	
212 Data Error Code: (212, xxx) where xxx 142, 143, 144 or 146	<p>Main Temperature Probe Failure</p> <p>The control system has detected an issue with the main temperature probe.</p> <p>The control system has detected an issue with the main temperature probe.</p> <ol style="list-style-type: none"> 1. Ensure the wire connections for the main temp probe are clean and secure. 2. Ensure the wire harness for the main temp probe is free from damages. 3. If the problem continues, contact technical support or refer to the service handbook for further instructions. 	
213 Data Error Code: (213, 136) or (213, 243)	<p>Hardware Failure</p> <p>The control system has detected a flame sensor error.</p> <ol style="list-style-type: none"> 1. Ensure that the flame sensor wire harness is free of damages. 2. Ensure that the flame sensor wire connection on both ends is secure and free of contaminates. 3. Remove flame sensor and inspect for contaminates or damages in ceramic insulator. 4. Clean flame sensor rod with steel wool. 5. If the problem continues, contact technical support, or refer to the service handbook for further instructions. 	

Fault and Alert Messages		
FAULT CODE	Possible Causes - Check/Repair	Displayed Fault/Alert Message
<p>214</p> <p>Data Error Code: (215, 2400x) where x is the failed calibration reason described in the service handbook.</p>	<p>Software Failure</p> <p>The CSC has detected a software issue.</p> <ol style="list-style-type: none"> 1. Cycle the main power supply to the water heater by turning off the breaker/disconnect, then wait approximately 30 seconds and turn main power supply back on. 2. If problem continues, contact Technical Support or refer to the service handbook for further instructions. 	
<p>215</p> <p>Data Error Code: (215, 2400x) where x is the failed calibration reason described in the service handbook.</p>	<p>Calibration Error</p> <p>The CSC has detected a calibration error.</p> <ol style="list-style-type: none"> 1. The CSC has detected a software issue. 2. Cycle the main power supply to the water heater by turning off the breaker/disconnect, then wait approximately 30 seconds and turn main power supply back on. 3. If problem continues, contact Technical Support or refer to the service handbook for further instructions. 	
<p>216</p> <p>Data Error Code: (216, 137)</p>	<p>Gas Valve Circuit Fault</p> <p>The control system has detected a fault with the Gas Valve Circuit.</p> <ol style="list-style-type: none"> 1. Ensure wire connections on both ends are secure and free of contaminates. 2. Ensure wire harness is not damaged. 3. If problem continues, contact technical support, or refer to the service handbook for further instructions. 	
<p>217</p> <p>Data Error Code: (217, 242)</p>	<p>MDT Fault</p> <p>The control system has detected a fault with the Motor Driven Throttle (MDT).</p> <ol style="list-style-type: none"> 1. Ensure wire connections on both ends are secure and free of contaminates. 2. Ensure wire harness is not damaged. 3. If problem continues, contact technical support, or refer to the service handbook for further instructions. 	
<p>218</p> <p>Data Error Code: (209, 2014)</p>	<p>BMS Module Disconnected</p> <p>Communication with the BMS module has been lost. The control system has detected that the BMS is disconnected.</p> <ol style="list-style-type: none"> 1. Ensure BMS module is powered. 2. Ensure wire connections are secure and free of contaminates. 3. Ensure wire harness is free of damages. 4. If problem continues, contact technical support or refer to the service handbook for further instructions. 	

Fault and Alert Messages		
FAULT CODE	Possible Causes - Check/Repair	Displayed Fault/Alert Message
219	<p>Anode Shorted</p> <p>The central control board (TRC) is detecting low-resistance or a short to earth ground or the tank.</p> <p>Possible Causes:</p> <ol style="list-style-type: none"> 1. Water at anode area. 2. Contamination (solder, Loctite, WD40 etc.) between the anode top and the surrounding metal. 3. Sediment build up with a possible bridge to tank. 4. A loose anode wire touching the tank. 5. A bent anode shorting to the tank or an element. 	
220	<p>Power Anode Module failure</p> <p>Cycle the main power to the unit off and then on.</p> <p>The commercial power anode module (CPAM) needs to be replaced.</p>	
221 Data Error Code: 13	<p>Reset Lockout</p> <p>The control system has detected a Reset Lockout</p> <ol style="list-style-type: none"> 1. Cycle the main power to the water heater. 2. If problem continues, contact technical support, or refer to the service handbook for further instructions. 	
222 Data Error Code: (222, 2001)	<p>FMM Missing</p> <p>The control system has detected that the Flex Memory Module (FMM) is either missing or disconnected.</p> <ol style="list-style-type: none"> 1. Ensure the wire connections are secure and free of contaminates. 2. Ensure wire connection at terminal J2 on the TRC is secure. 3. Ensure all wire harnesses are free from damages. 4. Cycle the main power to the water heater. 5. If problem continues, contact technical support for further instructions. 	
223 Data Error Code: (223, 2006)	<p>Missing Display</p> <p>The display was found to be missing.</p> <p>The control system has detected that the User Interface Module (UIM) is either missing or disconnected.</p> <ol style="list-style-type: none"> 1. Ensure the wire connections are secure and free of contaminates. 2. Ensure wire connection at terminal J2 on the TRC is secure. 3. Ensure all wire harnesses are free from damages. 4. Cycle the main power to the water heater. 5. If problem continues, contact technical support for further instructions. 	

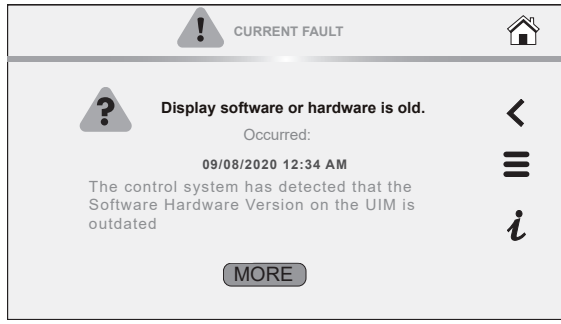
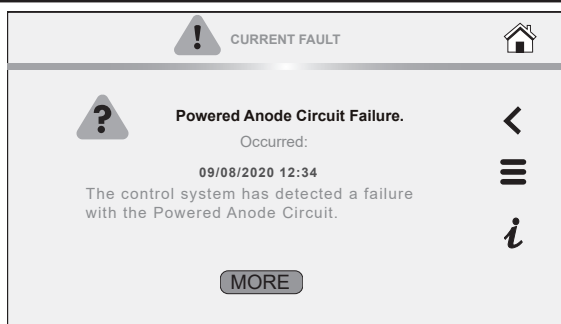
Fault and Alert Messages		
FAULT CODE	Possible Causes - Check/Repair	Displayed Fault/Alert Message
224 Data Error Code: (224, 2005)	<p>TRC Software or Hardware Is Old</p> <p>The control system has detected that the Software or Hardware Version on the TRC is outdated.</p> <p>The control system has detected that the Software or Hardware Version on the TRC is outdated.</p> <ol style="list-style-type: none"> Typically caused by replacing control system components with an older revision software. Contact technical support for further instructions. 	
225 (225, 2007)	<p>Display software or hardware is old</p> <p>The control system has detected that the Software Hardware Version on the UIM is outdated.</p> <ol style="list-style-type: none"> Typically caused by replacing control system components with an older revision software. Contact technical support for further instructions. 	
226 (226, 60xy) where x = 0 is on TRC-1000 board anode circuit. x = 1 is CPAM 1, x = 2 is CPAM 2 etc. y = 1, 2, 3, 5, 6 or 8)	<p>Powered Anode Circuit Failure</p> <p>The control system has detected a failure with the Powered Anode Circuit.</p> <ol style="list-style-type: none"> Cycle main power to the water heater. Contact technical support for further instructions. 	

Fault and Alert Messages		
FAULT CODE	Possible Causes - Check/Repair	Displayed Fault/Alert Message
227 (227, 4001)	<p>FMM Incompatible</p> <p>The control system has detected that the Software Version on the Flex Memory Module (FMM) is outdated.</p> <ol style="list-style-type: none"> Typically caused by replacing control system components with an older revision software. Contact technical support for further instructions. 	
228 (228, 2015)	<p>User Setpoints Error Detected</p> <p>Data corruption of user adjustable setpoints led to factory reset of default values.</p> <p>Toggle the Enable/Disable switch to Disable, wait 30 seconds and toggle back to Enable to clear fault and readjust setpoints</p>	

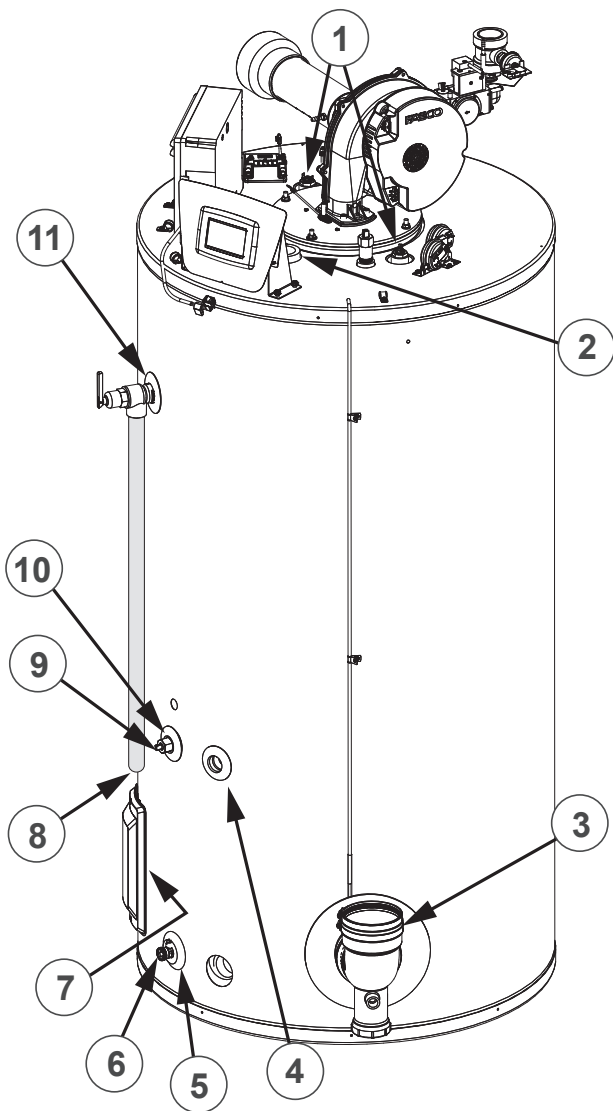

Figure 85. Leakage Checkpoints

⚠ WARNING	
Safety Hazard	
	<p>Failure to follow these instructions and safety messages could result in death or serious injury.</p> <p>Read and understand this instruction manual and the safety messages herein before installing or operating or servicing this water heater.</p> <p>This manual must remain with the water heater.</p>

Never use this water heater unless it is completely filled with water. To prevent damage to the tank, the tank must be filled with water. Water must flow from the hot water faucet before turning "ON" gas to the water heater.

1. *The anode rod fittings may be leaking.
2. *Condensation may be seen on pipes in humid weather or pipe connections may be leaking.
3. Condensate from the exhaust connection.
4. Leakage from recirculation plug or pipe connection.
5. *The drain valve may be leaking at the tank fitting.
6. Water from a drain valve may be due to the valve being slightly opened.
7. Leakage from the plug under the clean-out cover.
8. Small amounts of water from temperature-pressure relief valve may be due to thermal expansion or high water pressure in your area.
9. Leakage from the temperature probe connection (Not shown in figure).
10. *The temperature probe fitting may be leaking.
11. *The temperature-pressure relief valve may be leaking at the tank fitting.

CHECKING THE THREADED FITTINGS

Leakage from other water heaters, water lines, or ground seepage should also be checked.

1. * To check where threaded portion enters tank, do the following:
2. Insert cotton swab between jacket opening and fitting.
3. If cotton is wet, follow drain the tank and then remove fitting. See *Draining the Water Heater Storage Tank* (page 79).
4. Put pipe dope or thread-sealer tape on the threads and replace.
5. Then follow the instructions in *Filling The Water Heater* (page 56).

DIAGRAMS

WIRING DIAGRAMS

Circulation Pump Wiring Diagrams

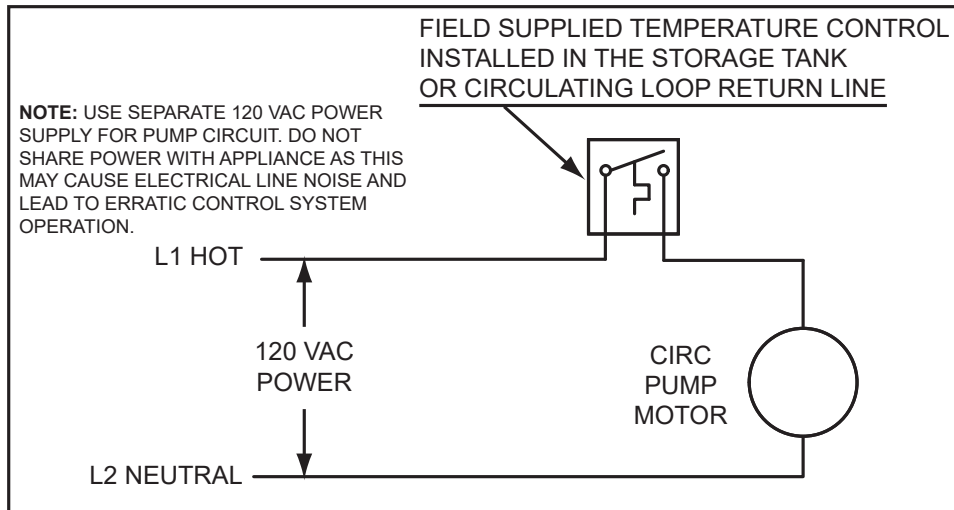

Figure 86. Recirculating Loop with Storage Tank or Building Recirculation

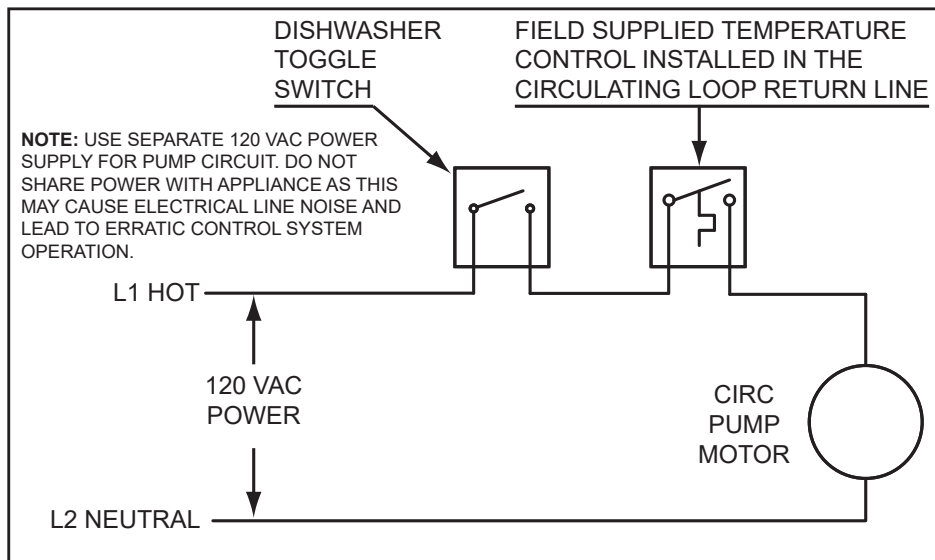

Figure 87. Recirculating Loop with Dish Washer and Toggle Switch

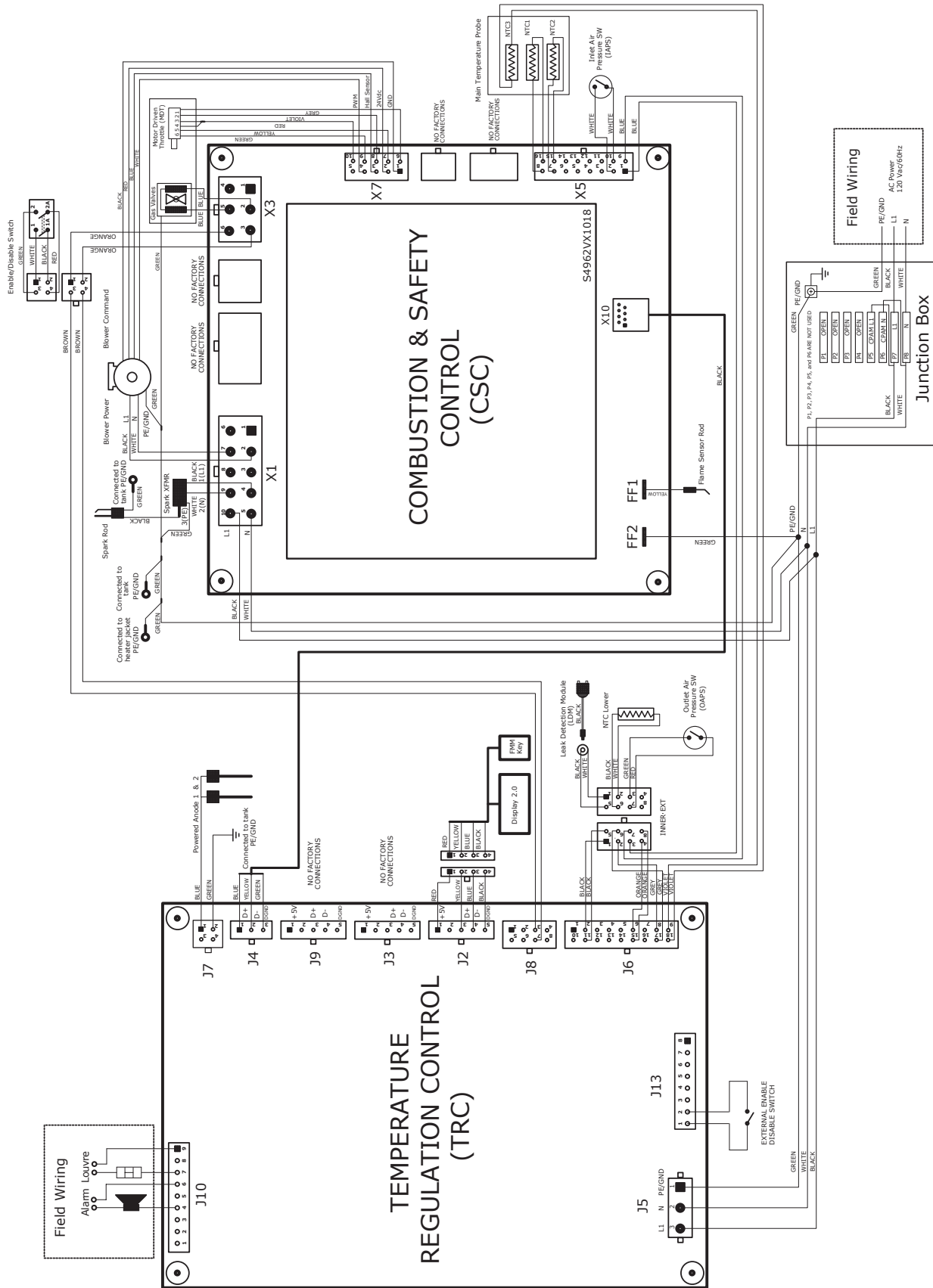

Figure 88. 60 Gallon Models Temperature Regulation and Combustion and Safety Control Wiring Diagram

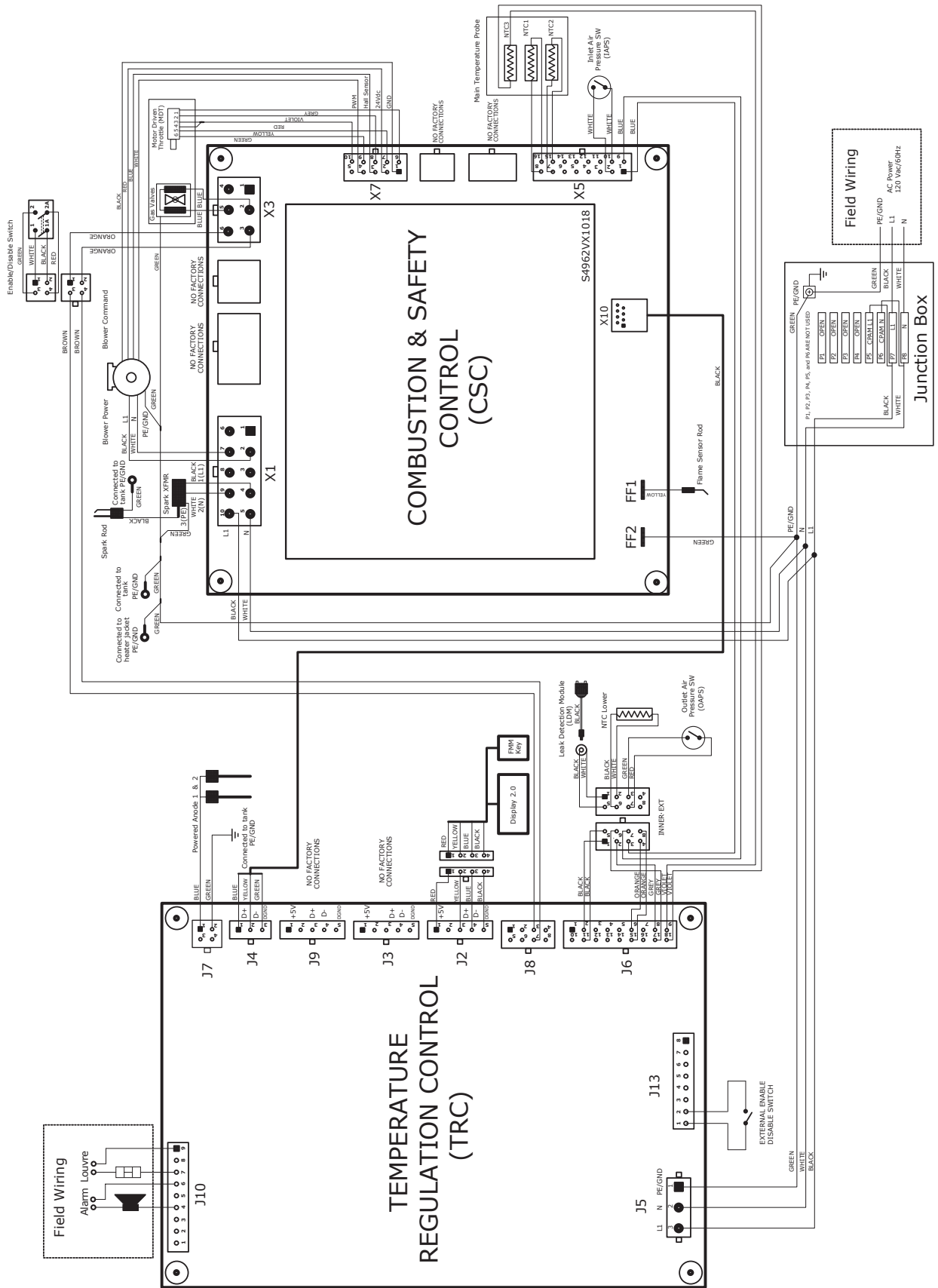

Figure 89. 100 Gallon Models - Temperature Regulation and Combustion and Safety Control Wiring Diagram

WATER PIPING DIAGRAMS

One Water Heater, Single Temperature with Building Recirculation

Before installation of water piping review the following:

1. See *Mixing Valves* (page 22).
2. See *Dish-washing Machines* (page 22).
3. See *Temperature-Pressure Relief Valve* (page 22).
4. See *Closed Water Systems* (page 22) and *Thermal Expansion* (page 22).

5. See *Water Line Connections* (page 54).
6. If a pump is being installed between a water heater and storage tank or on a building recirculation loop wire according to *Figure 86* (page 101).
7. If a pump is being installed in a recirculation loop between the water heater and a commercial dishwasher wire according to *Figure 87* (page 101).

WARNING: THIS DRAWING SHOWS A SUGGESTED PIPING CONFIGURATION AND OTHER DEVICES. CHECK WITH LOCAL CODES AND ORDINANCES FOR ADDITIONAL REQUIREMENTS.

ANY MATERIAL, COMPONENT, OR VENDOR CHANGE MUST HAVE PRIOR APPROVAL BY THE APPLICABLE PRODUCT ENGINEERING DEPARTMENT.

LEGEND

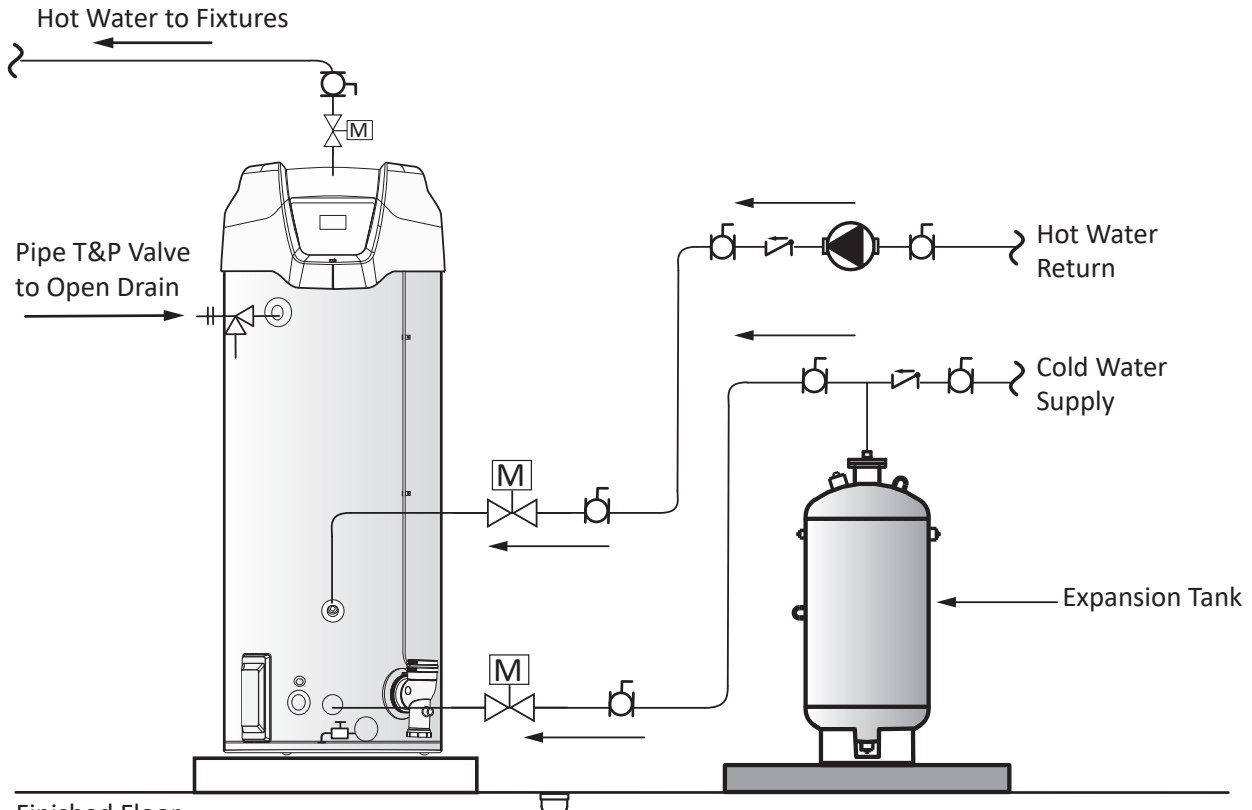
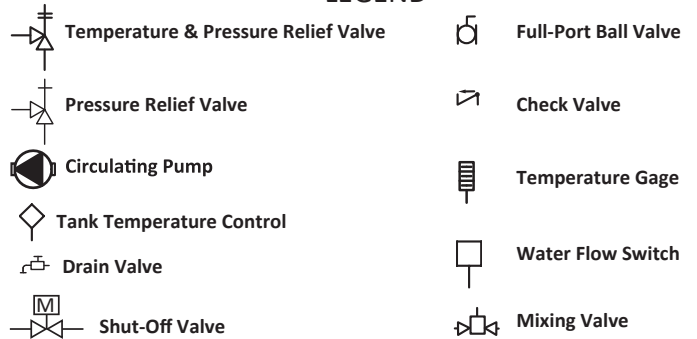

NOTES:

1. Preferred piping diagram.
2. The temperature and pressure relief valve setting shall not exceed pressure rating of any component in the system.
3. Service valves are shown for servicing unit. However, local codes shall govern their usage.
4. Ensure that any installed recirculation system does not bypass or interfere in any way with shut-off valves.

Before installation of water piping review the following:

1. See *Mixing Valves* (page 22).
2. See *Dish-washing Machines* (page 22).
3. See *Temperature-Pressure Relief Valve* (page 22).
4. See *Closed Water Systems* (page 22) and *Thermal Expansion* (page 22).

5. See *Water Line Connections* (page 54).
6. If a pump is being installed between a water heater and storage tank or on a building recirculation loop wire according to *Figure 86* (page 101).
7. If a pump is being installed in a recirculation loop between the water heater and a commercial dishwasher wire according to *Figure 87* (page 101).

WARNING: THIS DRAWING SHOWS A SUGGESTED PIPING CONFIGURATION AND OTHER DEVICES. CHECK WITH LOCAL CODES AND ORDINANCES FOR ADDITIONAL REQUIREMENTS.

ANY MATERIAL, COMPONENT, OR VENDOR CHANGE MUST HAVE PRIOR APPROVAL BY THE APPLICABLE PRODUCT ENGINEERING DEPARTMENT.

LEGEND

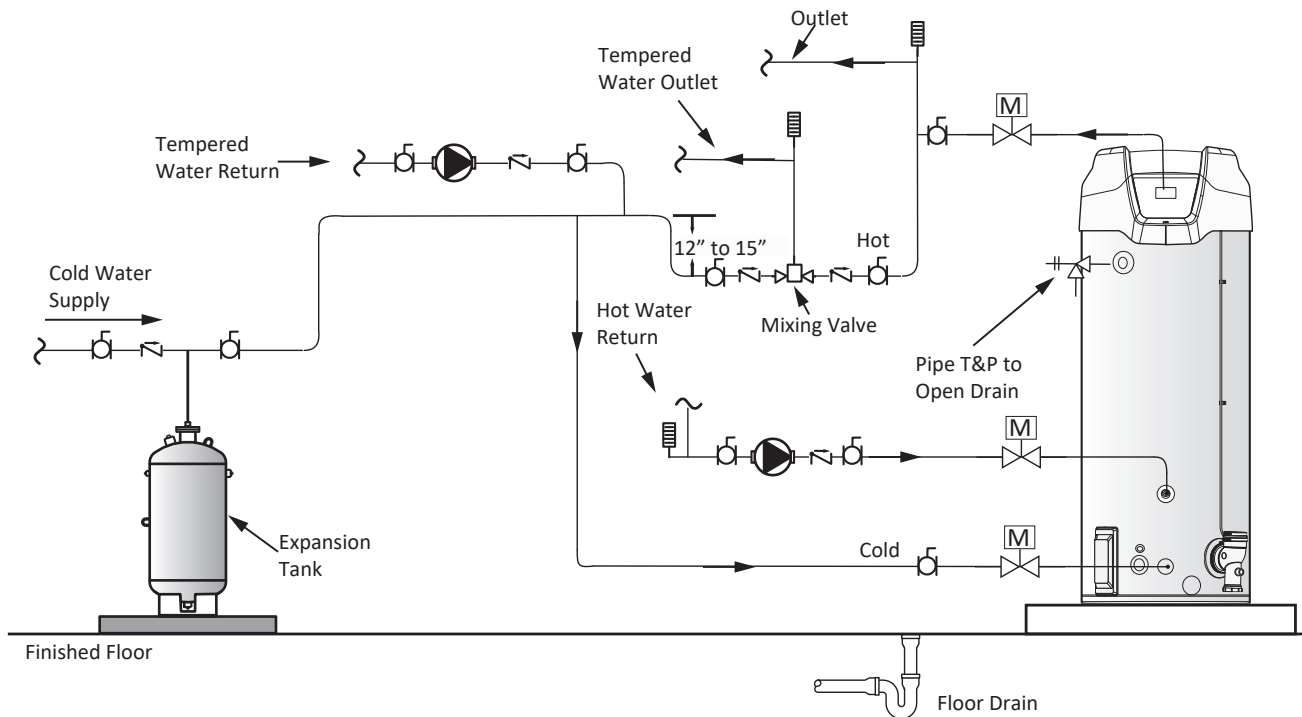
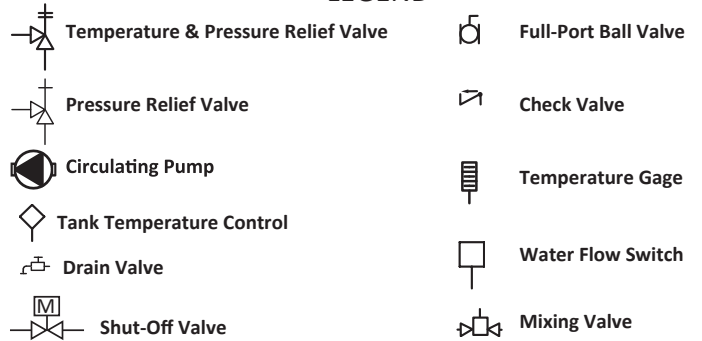

NOTES:

1. Preferred piping diagram.
2. The temperature and pressure relief valve setting shall not exceed pressure rating of any component in the system.
3. Service valves are shown for servicing unit. However, local codes shall govern their usage.
4. Ensure that any installed recirculation system does not bypass or interfere in any way with shut-off valves.

Before installation of water piping review the following:

1. See *Mixing Valves* (page 22).
2. See *Dish-washing Machines* (page 22).
3. See *Temperature-Pressure Relief Valve* (page 22).
4. See *Closed Water Systems* (page 22) and *Thermal Expansion* (page 22).

5. See *Water Line Connections* (page 54).
6. If a pump is being installed between a water heater and storage tank or on a building recirculation loop wire according to *Figure 86* (page 101).
7. If a pump is being installed in a recirculation loop between the water heater and a commercial dishwasher wire according to *Figure 87* (page 101).

WARNING: THIS DRAWING SHOWS A SUGGESTED PIPING CONFIGURATION AND OTHER DEVICES. CHECK WITH LOCAL CODES AND ORDINANCES FOR ADDITIONAL REQUIREMENTS.

ANY MATERIAL, COMPONENT, OR VENDOR CHANGE MUST HAVE PRIOR APPROVAL BY THE APPLICABLE PRODUCT ENGINEERING DEPARTMENT.

LEGEND

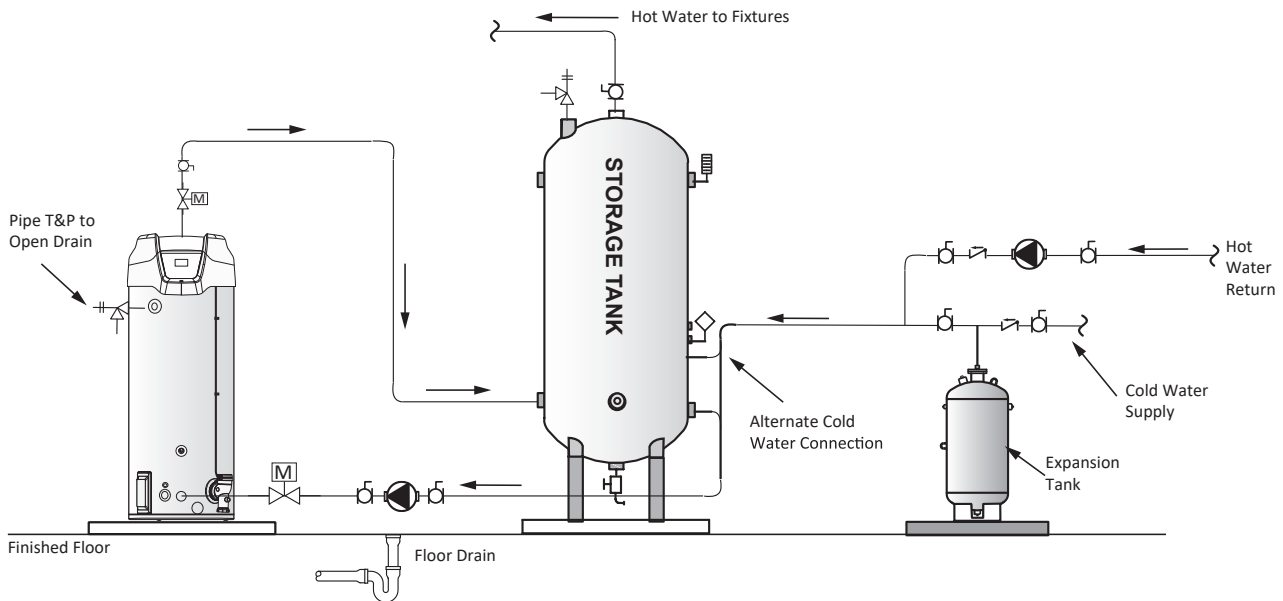
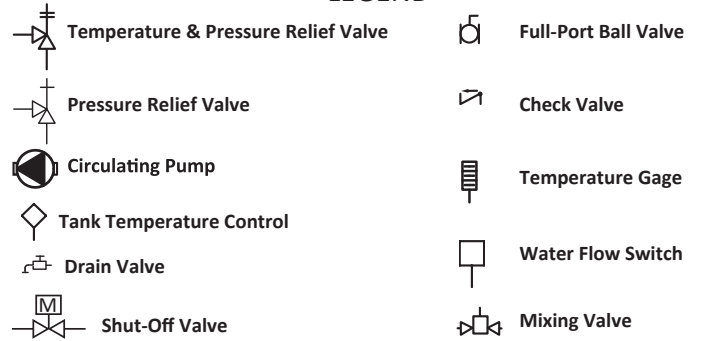

NOTES:

1. Preferred piping diagram.
2. The temperature and pressure relief valve setting shall not exceed pressure rating of any component in the system.
3. Service valves are shown for servicing unit. However, local codes shall govern their usage.
4. The tank temperature control should be wired to and control the pump between the water heater(s) and the storage tank(s).
5. The water heater's operating thermostat should be set 5 degrees F higher than the tank temperature control.
6. Ensure that any installed recirculation system does not bypass or interfere in any way with shut-off valves.

Before installation of water piping review the following:

1. See *Mixing Valves* (page 22).
2. See *Dish-washing Machines* (page 22).
3. See *Temperature-Pressure Relief Valve* (page 22).
4. See *Closed Water Systems* (page 22) and *Thermal Expansion* (page 22).

5. See *Water Line Connections* (page 54).
6. If a pump is being installed between a water heater and storage tank or on a building recirculation loop wire according to *Figure 86* (page 101).
7. If a pump is being installed in a recirculation loop between the water heater and a commercial dishwasher wire according to *Figure 87* (page 101).

WARNING: THIS DRAWING SHOWS A SUGGESTED PIPING CONFIGURATION AND OTHER DEVICES. CHECK WITH LOCAL CODES AND ORDINANCES FOR ADDITIONAL REQUIREMENTS.

ANY MATERIAL, COMPONENT, OR VENDOR CHANGE MUST HAVE PRIOR APPROVAL BY THE APPLICABLE PRODUCT ENGINEERING DEPARTMENT.

LEGEND

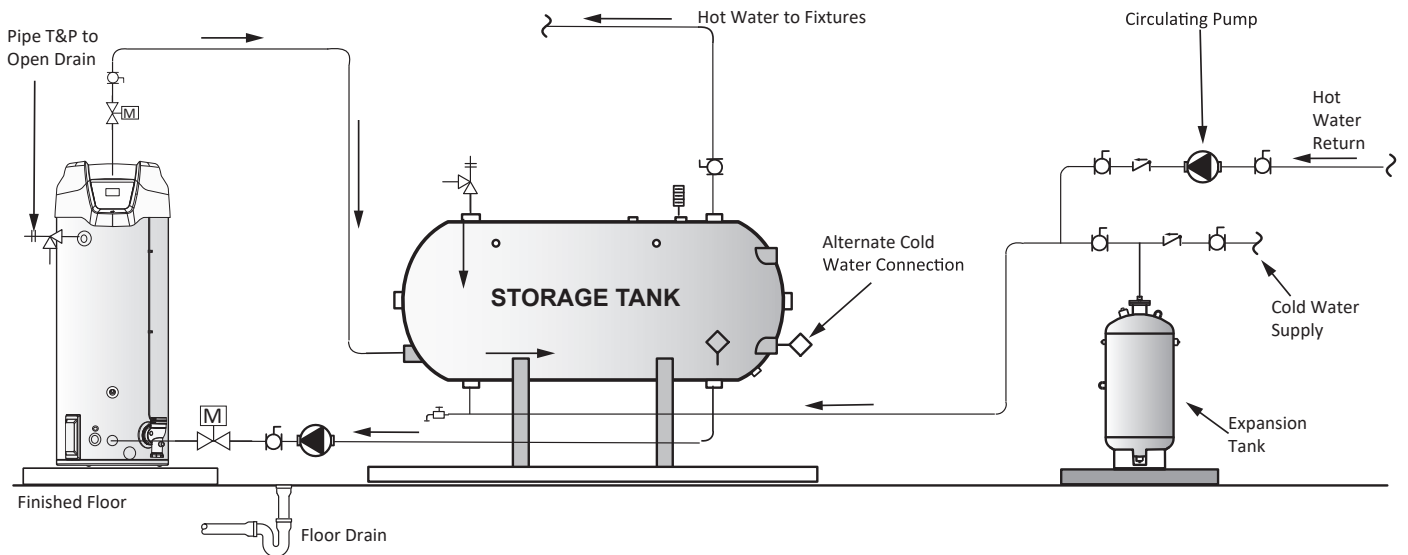
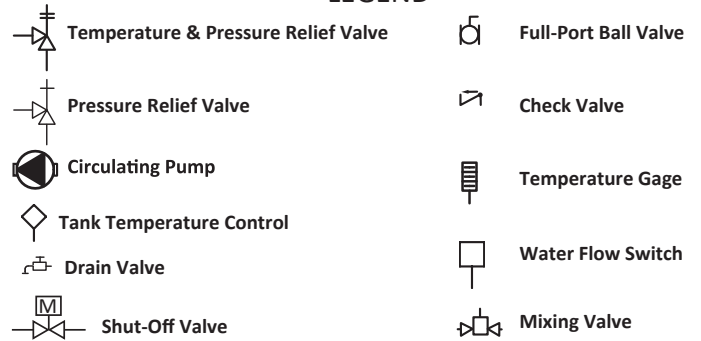

NOTES:

1. Preferred piping diagram.
2. The temperature and pressure relief valve setting shall not exceed pressure rating of any component in the system.
3. Service valves are shown for servicing unit. However, local codes shall govern their usage.
4. The tank temperature control should be wired to and control the pump between the water heater(s) and the storage tank(s).
5. The water heater's operating thermostat should be set 5 degrees F higher than the tank temperature control.
6. Ensure that any installed recirculation system does not bypass or interfere in any way with shut-off valves.

Before installation of water piping review the following:

1. See *Mixing Valves* (page 22).
2. See *Dish-washing Machines* (page 22).
3. See *Temperature-Pressure Relief Valve* (page 22).
4. See *Closed Water Systems* (page 22) and *Thermal Expansion* (page 22).

5. See *Water Line Connections* (page 54).
6. If a pump is being installed between a water heater and storage tank or on a building recirculation loop wire according to *Figure 86* (page 101).
7. If a pump is being installed in a recirculation loop between the water heater and a commercial dishwasher wire according to *Figure 87* (page 101).

WARNING: THIS DRAWING SHOWS A SUGGESTED PIPING CONFIGURATION AND OTHER DEVICES. CHECK WITH LOCAL CODES AND ORDINANCES FOR ADDITIONAL REQUIREMENTS.

ANY MATERIAL, COMPONENT, OR VENDOR CHANGE MUST HAVE PRIOR APPROVAL BY THE APPLICABLE PRODUCT ENGINEERING DEPARTMENT.

LEGEND

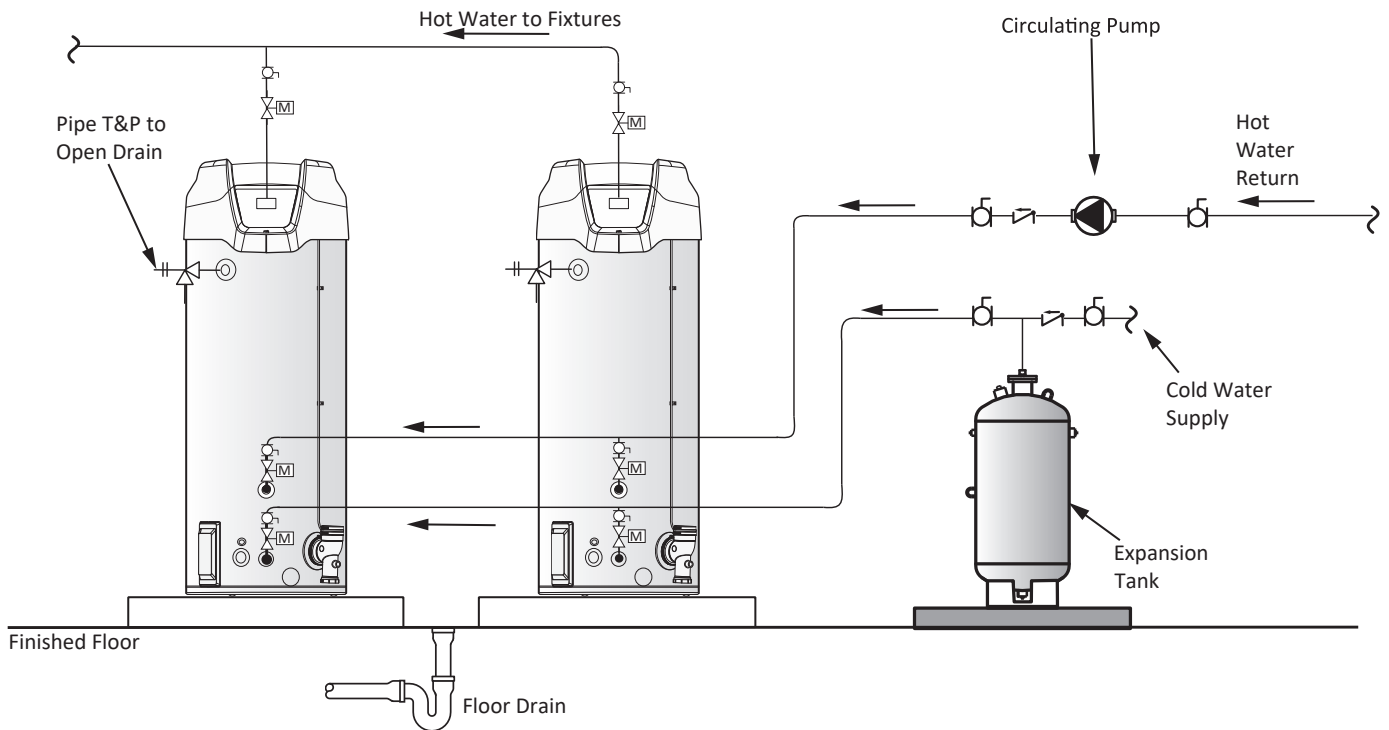
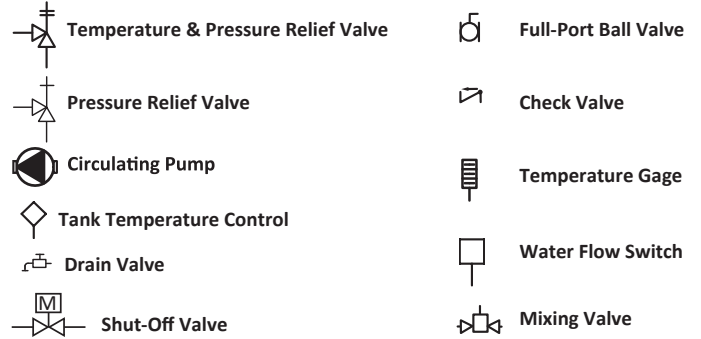

NOTES:

1. Preferred piping diagram.
2. The temperature and pressure relief valve setting shall not exceed pressure rating of any component in the system.
3. Service valves are shown for servicing unit. However, local codes shall govern their usage.
4. Ensure that any installed recirculation system does not bypass or interfere in any way with shut-off valves.

Before installation of water piping review the following:

1. See *Mixing Valves* (page 22).
2. See *Dish-washing Machines* (page 22).
3. See *Temperature-Pressure Relief Valve* (page 22).
4. See *Closed Water Systems* (page 22) and *Thermal Expansion* (page 22).

5. See *Water Line Connections* (page 54).
6. If a pump is being installed between a water heater and storage tank or on a building recirculation loop wire according to *Figure 86* (page 101).
7. If a pump is being installed in a recirculation loop between the water heater and a commercial dishwasher wire according to *Figure 87* (page 101).

WARNING: THIS DRAWING SHOWS A SUGGESTED PIPING CONFIGURATION AND OTHER DEVICES. CHECK WITH LOCAL CODES AND ORDINANCES FOR ADDITIONAL REQUIREMENTS.

ANY MATERIAL, COMPONENT, OR VENDOR CHANGE MUST HAVE PRIOR APPROVAL BY THE APPLICABLE PRODUCT ENGINEERING DEPARTMENT.

LEGEND

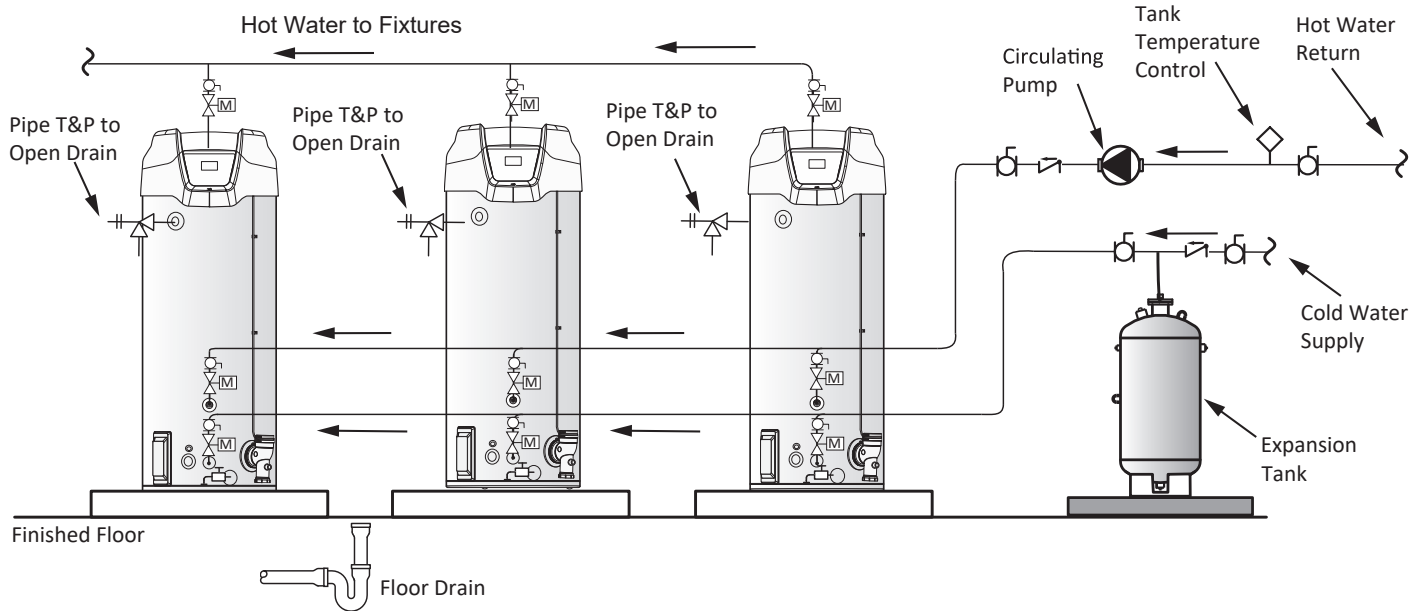
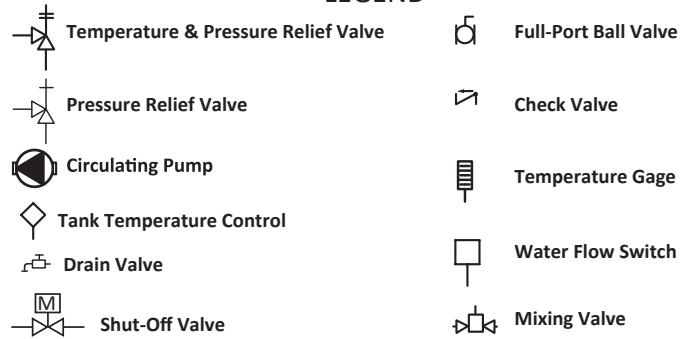

NOTES:

1. Preferred piping diagram.
2. The temperature and pressure relief valve setting shall not exceed pressure rating of any component in the system.
3. Service valves are shown for servicing unit. However, local codes shall govern their usage.
4. Ensure that any installed recirculation system does not bypass or interfere in any way with shut-off valves.

Before installation of water piping review the following:

1. See *Mixing Valves* (page 22).
2. See *Dish-washing Machines* (page 22).
3. See *Temperature-Pressure Relief Valve* (page 22).
4. See *Closed Water Systems* (page 22) and *Thermal Expansion* (page 22).
5. See *Water Line Connections* (page 54).
6. If a pump is being installed between a water heater and storage tank or on a building recirculation loop wire according to *Figure 86* (page 101).
7. If a pump is being installed in a recirculation loop between the water heater and a commercial dishwasher wire according to *Figure 87* (page 101).

WARNING: THIS DRAWING SHOWS A SUGGESTED PIPING CONFIGURATION AND OTHER DEVICES. CHECK WITH LOCAL CODES AND ORDINANCES FOR ADDITIONAL REQUIREMENTS.

ANY MATERIAL, COMPONENT, OR VENDOR CHANGE MUST HAVE PRIOR APPROVAL BY THE APPLICABLE PRODUCT ENGINEERING DEPARTMENT.

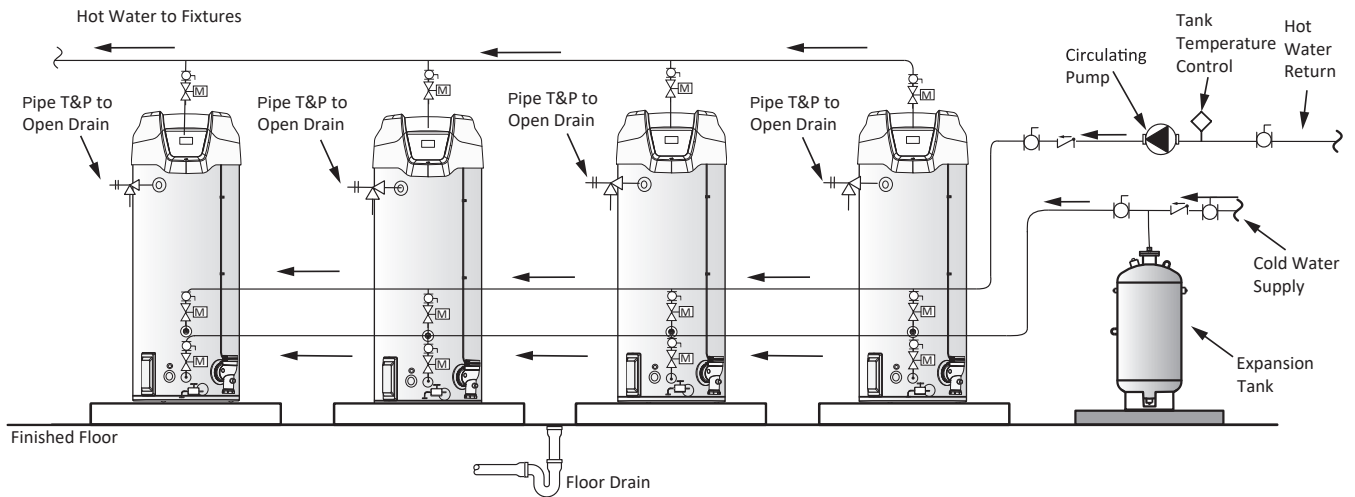
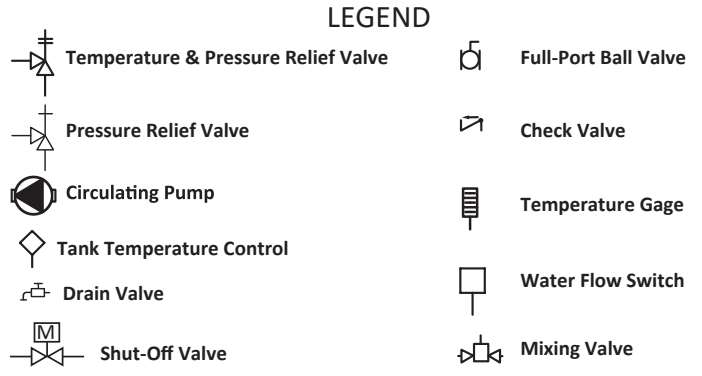

- NOTES:**
1. Preferred piping diagram.
 2. The temperature and pressure relief valve setting shall not exceed pressure rating of any component in the system.
 3. Service valves are shown for servicing unit. However, local codes shall govern their usage.
 4. Ensure that any installed recirculation system does not bypass or interfere in any way with shut-off valves.

