

Air Source Heat Pump Water Heater

Installation & Operation Manual
Models: 60 - 350*
Series: 100

⚠ WARNING If the information in this manual is not followed exactly, electrical shock or excessive pressure may result causing property damage, personal injury, or loss of life.

-- Installation and service must be performed by a qualified installer or service agency.



⚠ WARNING

This manual must only be used by a qualified heating installer / service technician. Read all instructions, including this manual and the Air Source Heat Pump Water Heater Service Manual, before installing. Perform steps in the order given. Failure to comply could result in severe personal injury, death, or substantial property damage.

Save this manual for future reference.



LOW LEAD CONTENT



*Models 200 through 350 are composed of combinations of models 60 and 140 which are the certified units.

Contents

HAZARD DEFINITIONS	3
PLEASE READ BEFORE PROCEEDING	4-5
INTRODUCTION	6-7
Installer Qualifications	6
Preparing for Installation	6-7
THE AIR SOURCE HEAT PUMP WATER HEATER	
- HOW IT WORKS	8-14
Components	8-12
Principle of Operation	13
The Refrigeration Cycle	13
Air/ Water Temperature Range	14
Refrigerant Charge	14
Storage Recommendations/ Equipment Disposal	14
PERFORMANCE	15
1. DETERMINE WATER HEATER LOCATION	
Indoor/Outdoor Installation/Clearances	16
Provide Air Openings to Room	16
Flooring Foundation	18
Seismic Bracing	18
Vent and Air Ducts	18
Air Temperature	18
Electrical Requirements	18
Corrosive Contaminants and Sources	19
2. PREPARE WATER HEATER	
Remove Water Heater From Wood Pallet	20
Storage & Handling	20
Assemble Manifold	21
3. INSTALLING WATER HEATER	
Required Ability	22
Required Tools & Material	22
Unit Placement	22
Electrical Connections	23
Water Connections	23
Single Tank Configuration	24
Multi-Tank Preheat Configuration	24
Condensate Drain Line	24
Standard Tank Thermostat	24
Water Temperature	24
4. SYSTEM PIPING	
System Water Piping Method	25
Water Connections	25
General Piping Information	25
Cold Water Supply	25
Water Pressure	25
Closed Water Systems	25
Water Chemistry	25
Condensate Removal	25
Contaminated Water	26
Scalding	26
Piping Components	26
Temperature Sensor Installation	27
Tank Selection	27
Solar Tanks	27
Piping Diagrams	28-35
5. AIR FLOW AND DUCTING	
General Guidelines	36
Duct Sizing	36
Duct Insulation	36
Make Duct Connections	36
Ducting Multiple Units	36
Building Air Pressure	36
Negative Pressure	36
Positive Pressure	36
When to Install Ducting	36
Supply Air Ducting	37
Return Air Ducting	38
6. OUTDOOR INSTALLATIONS	
Outdoor Air Inlet and Outlet	39
7. FIELD WIRING	
Line Voltage Connections	40
Low Voltage Connections	42
Wiring of the Cascade	43
8. INSTALLATION CHECKLIST	45
9. START-UP	46-51
10. OPERATING INFORMATION	
General	52
Cascade	54
Sequence of Operation	55
Water Heater Control Module	56
11. MAINTENANCE	
Maintenance and Annual Start-up	57
12. DIAGRAMS	
Ladder Diagram	65
Wiring Diagram	66
Revision Notes	Back Cover

Hazard definitions

The following defined terms are used throughout this manual to bring attention to the presence of hazards of various risk levels or to important information concerning the life of the product.

 DANGER

DANGER indicates an imminently hazardous situation which, if not avoided, will result in death or serious injury.

 WARNING

WARNING indicates a potentially hazardous situation which, if not avoided, could result in death or serious injury.

 CAUTION

CAUTION indicates a potentially hazardous situation which, if not avoided, may result in minor or moderate injury.

CAUTION

CAUTION used without the safety alert symbol indicates a potentially hazardous situation which, if not avoided, may result in property damage.

NOTICE

NOTICE indicates special instructions on installation, operation, or maintenance that are important but not related to personal injury or property damage.

Please read before proceeding

WARNING Read all instructions, including this manual and the Water Heater Service Manual, before installing. Perform steps in the order given.
Have this water heater serviced/ inspected by a qualified service technician, at least annually.
Failure to comply with the above could result in severe personal injury, death, or substantial property damage.

NOTICE

When calling or writing about the water heater – Please have the water heater model and serial number from the water heater rating plate.
Consider piping and installation when determining water heater location.
Any claims for damage or shortage in shipment must be filed immediately against the transportation company by the consignee.
Factory warranty (shipped with unit) does not apply to units improperly installed or improperly operated.

WARNING Failure to adhere to the guidelines on this page can result in severe personal injury, death, or substantial property damage.

WARNING If the information in this manual is not followed exactly, electrical shock or excessive pressure may result causing property damage, personal injury, or loss of life.

WARNING System contains oil and refrigerant under high pressure. Recover refrigerant to relieve pressure before opening refrigeration system. See unit label for refrigerant type. Do not use non-approved refrigerants, refrigerant substitutes, or refrigerant additives.
Failure to follow proper procedures or the use of non-approved refrigerants, refrigerant substitutes, or refrigerant additives could result in death or serious injury or equipment damage.

WARNING Electrical Shock Hazard
Disconnect power to the water heater before performing any service.
Failure to follow these instructions can result in personal injury or death.

WARNING DO NOT install units in rooms or environments that contain corrosive contaminants (see Table 1-3 on page 19). Failure to comply could result in severe personal injury, death, or substantial property damage.

WARNING The California Safe Drinking Water and Toxic Enforcement Act requires the Governor of California to publish a list of substances known to the State of California to cause cancer, birth defects, or other reproductive harm, and requires businesses to warn of potential exposure to such substances.

This product contains a chemical known to the State of California to cause cancer, birth defects, or other reproductive harm. This water heater can cause low level exposure to some of the substances listed in the Act.

WARNING Proper grounding of unit
This heat pump water heater must be grounded in accordance with the National Electrical Code and/or local codes. These must be followed in all cases. Failure to ground this water heater properly may cause erratic control system operation.
This heat pump water heater must be connected to a grounded metal, permanent wiring system; or an equipment grounding conductor must be run with the circuit conductors and connected to the equipment grounding terminal or lead on the water heater.

When servicing the water heater –

WARNING Installation and service must be performed by a qualified installer, or service agency.
To avoid electric shock, disconnect electrical supply before performing maintenance.
To avoid severe burns, allow the water heater to cool before performing maintenance.

Water heater operation –

- Do not block flow of ventilation air to or from the water heater.
- Should overheating occur disconnect electrical supply to unit.
- Do not use the water heater if any part has been under water. The possible damage to a flooded appliance can be extensive and present numerous safety hazards. Any appliance that has been under water must be replaced.

Please read before proceeding *(continued)*

⚠ WARNING This appliance is not intended for use by persons (including children) with reduced physical, sensory or mental capabilities, or lack of experience and knowledge, unless they have been given supervision or instruction concerning use of the appliance by a person responsible for their safety.

⚠ WARNING Children should be supervised to ensure that they do not play with the appliance.

Introduction

Thank you for purchasing this heat pump water heater. Properly installed and maintained, it should give you years of trouble-free service.

Abbreviations found in this instruction manual include:

- HPWH - Heat Pump Water Heater
- ANSI - American National Standards Institute
- ASME - American Society of Mechanical Engineers
- NEC - National Electrical Code
- NFPA - National Fire Protection Association
- AHRI - Air-conditioning, Heating and Refrigeration Institute

INSTALLER QUALIFICATIONS

Installation and service of this water heater requires ability equivalent to that of a Qualified Agency (as defined by ANSI below) in the field involved. Installation skills such as plumbing, and electrical supply are required in addition to electrical testing skills when performing service.

This heat pump water heater contains R-513A refrigerant and is regulated as a stationary refrigeration appliance under Section 608 of the Clean Air Act. Servicing of the refrigeration circuit must only be performed by agencies or individuals possessing Type II or Universal certification as defined in Section 608 of the Clean Air Act.

ANSI Z2223.1 2006 Sec. 3.3.83: "Qualified Agency" - "Any individual, firm, corporation or company that either in person or through a representative is engaged in and is responsible for (a) the installation, testing or replacement of piping or (b) the connection, installation, testing, repair or servicing of appliances and equipment; that is experienced in such work; that is familiar with all precautions required; and that has complied with all the requirements of the authority having jurisdiction.

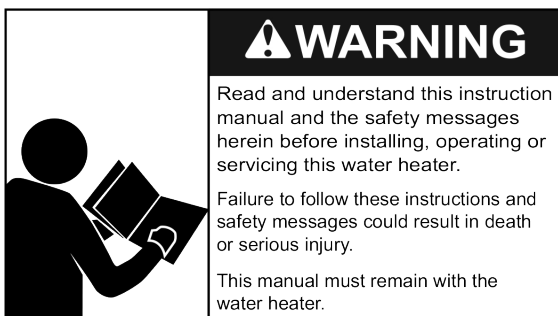

PREPARING FOR INSTALLATION

1. Read the entire manual carefully. If you don't follow the safety rules, the heat pump water heater may not operate safely. It could cause DEATH, SERIOUS BODILY INJURY AND/OR PROPERTY DAMAGE. This manual contains instructions for the installation, operation, and maintenance of the heat pump water heater (HPWH). It also contains warnings throughout the manual that you must read and be aware of. All warnings and all instructions are essential to the proper operation of the HPWH and your safety. **READ THE ENTIRE MANUAL BEFORE ATTEMPTING TO INSTALL OR OPERATE THIS WATER HEATING APPLIANCE.**

Detailed installation diagrams are in this manual. These diagrams will serve to provide the installer with a reference for the materials and suggested methods of piping. **IT IS NECESSARY THAT ALL WATER PIPING AND THE ELECTRICAL WIRING BE INSTALLED AND CONNECTED AS SHOWN IN THE DIAGRAMS.**

Particular attention should be given to the installation of the system (tank) temperature control.

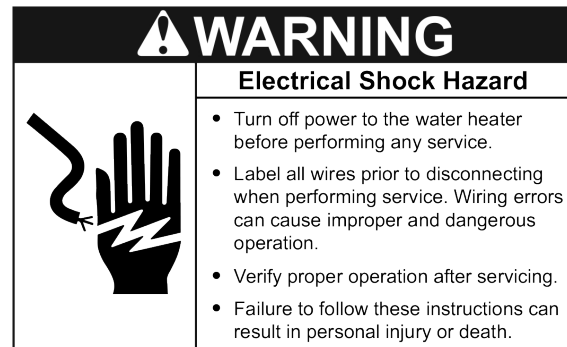

Be sure to turn off power when working on or near the electrical system of the heat pump. Never touch electrical components with wet hands or when standing in water. When replacing fuses always use the correct size for the circuit.

The principal components of the HPWH are identified in the How It Works section of this manual on page 8. The rating label on the HPWH also provides useful information. These references should be used to identify the heat pump, its components, and optional equipment.

Introduction *(continued)*

2. The installation must conform with these instructions and the local code authority having jurisdiction and the requirements of the power company. In the absence of local codes, the installation must comply with the latest editions of the National Electrical Code, ANSI/NFPA 70 or the Canadian Electrical code CSA C22.1. The National Electrical Code may be ordered from: National Fire Protection Association, 1 Batterymarch Park, Quincy, MA 02269.

The Canadian Electrical Code is available from the Canadian Standards Association, 8501 East Pleasant Valley Road, Cleveland, OH 44131.

3. If after reading this manual you have any questions or do not understand any portion of the instructions DO NOT proceed with the installation. Call the toll free number 1-800-722-2101 for technical assistance.
4. In order to expedite your request, please have full model and serial number available for the technician.
5. Carefully consider your intended placement and location for the HPWH. See Determine Water Heater Location on page 16.
6. Installation and service of this HPWH requires ability equivalent to that of a licensed tradesman or Qualified Agency in the field involved. See Qualifications on page 5.
7. For installation in California, the HPWH unit must be braced or anchored to avoid falling or moving during an earthquake. Consult the factory.
8. Ensure the Power supply voltage and phase at the job site matches the power requirements on the HPWH rating label before installation begins. Energizing the HPWH with the wrong voltage or phase will cause permanent damage to the unit.

The Air Source Heat Pump Water Heater - How it works...

1. **Scroll Compressor**
The refrigerant enters the compressor through the suction line as a low pressure vapor. The scroll compressor uses two interweaving spirals, one stationary and one rotating to compress the vapor. The refrigerant leaves the compressor through the discharge line as a high pressure gas.
2. **Core Sense Module**
Core Sense Module monitors and protects the compressor from high discharge temperature and current issues. It can also alert for refrigeration system faults.
3. **4-Way Reversing Valve**
The 4-way valve is used to change the flow direction of the refrigerant. During normal operation the refrigerant flows from the compressor through the 4 way valve to the condenser, but when controls signal the unit to go into defrost mode, the coil on the 4 way valve actuates to change flow. When actuated for defrost mode, the valve sends refrigerant from the compressor to the evaporators.
4. **Condenser**
The condenser is a brazed plate double wall heat exchanger that allows refrigerant and water flow in counter current directions to pull heat from the refrigerant into the water.
5. **Receiver Tank**
The receiver tank is placed after the condenser and is used to hold excess refrigerant at low ambient temperatures.
6. **Filter Drier**
The filter drier is a hermetic bi-flow filter containing check valves that force refrigerant flow from the outside of the filter core to the center of the filter where large contaminant particles are trapped along with any moisture to prevent damage to the compressor.
7. **Sight Glass**
The sight glass is placed in the liquid line to observe when refrigerant charge is low or moisture is in the system.
8. **Electronic Expansion Valve (EEV)**
The electronic expansion valve is used to regulate refrigerant flow to the evaporators. Electronic expansion valve position is controlled by electrical signals that cause polarity changes between the windings inside the valve signaling the valve to move through pulses resulting in movement in steps to open and close.
9. **Evaporator**
The evaporators are tube and fin type heat exchangers with distributor heads to feed each circuit. When air is forced through the fins, heat is absorbed from the air and transferred to the refrigerant inside the tubes. Refrigerant enters the evaporators as a mixture of liquid and vapor, and travels through the circuits absorbing the heat from the air transforming into a vapor.
10. **Evaporator Inlet Manifolds**
There are two Evaporator Inlet Manifolds where refrigerant enters the evaporator during normal operation.
11. **Evaporator Outlet Manifolds**
There are two Evaporator Outlet Manifolds where refrigerant leaves the evaporator during normal operation.
12. **Accumulator**
An accumulator is positioned just prior to the compressor. The purpose of an accumulator is to prevent liquid refrigerant from entering into the compressor. Refrigerant is deposited into the tank through a dip tube and any liquid settles in the bottom. The outlet pulls refrigerant from the top of the tank where vapor rises.
13. **Water Heater Outlet Temperature Sensor**
This sensor monitors water heater outlet water temperature. The control module adjusts motorized ball valve and pump speed so the outlet temperature is correct.
14. **Water Outlet**
Water connection that supplies hot water to the tank.
15. **Water Inlet**
Water connection that returns water from the tank to the heat pump.
16. **Water Heater Inlet Temperature Sensor**
This sensor monitors inlet water temperature. The control module adjusts motorized ball valve and pump speed so the outlet temperature is correct.
17. **Flow Sensor**
The flow sensor is a rotary or turbine type sensor that measures the flow rate of the inlet water, and the control module uses the information to adjust water flow with the motorized ball valve and variable speed pump.
18. **Motorized Ball Valve**
The motorized ball valve regulates water flow on the outlet water pipe.
19. **Service Valves**
Service valves are located on the suction and discharge connection of the compressor and are for isolating the compressor for service. The ports on these valves are used to connect gauges for system evaluation.
20. **Low Pressure Transducer**
The low pressure transducer is tapped into the suction line to monitor pressure of the refrigerant entering the compressor.
21. **High Pressure Transducer**
The high pressure transducer is tapped into the discharge line to monitor pressure of the refrigerant leaving the compressor.
22. **Low Pressure Switch**
The low pressure switch is located on the suction line to trigger the compressor to shut off if pressure goes below the minimum recommended pressure for the compressor (5 psig).
23. **High Pressure Switch**
The high pressure switch is located on the discharge line to trigger the compressor to shut down if the refrigerant pressure exceeds the recommended safe pressure (400 psig).
24. **Indicator Light**
The indicator light illuminates when the unit is in a fault status.
25. **Crankcase Heater**
The crankcase heater is mounted around the base of the compressor to prevent the migration and condensation of refrigerant.
26. **High Voltage Junction Box**
The junction box contains the connection points for the line voltage power, fuses, and power switch.
27. **Junction Box**
Conduit connection points for pump and booster fan connections.
28. **Drain Connection**
Connects the drain line to a 1" hose connection.
29. **Access Panel - Front and Rear**
The front access cover provides access to the compressor and control panel while the rear cover allow access to water lines, junction box, and refrigerant lines from receiver tank to EEV's.
30. **Inspection Window**
The polycarbonate window that provides a view of error display on the control board inside the control panel.
31. **High Limit Switch**
Device that monitors the outlet water temperature. If the temperature exceeds its setting, the circuit is open, shutting the water heater down.
32. **Control Panel**
The control panel houses the heat pump control board, contactors and relays, and 120v to 24v transformer.
33. **Axial Fan**
The axial fan is located on top of the unit and is used to pull air through the evaporators.
34. **Suction Line**
The suction line is the pipe feeding refrigerant into the compressor.
35. **Discharge Line**
The discharge line is the pipe that connects to the outlet of the compressor for refrigerant exiting the compressor.

The Air Source Heat Pump Water Heater - How it works...

36. Unit Pump

The unit pump is variable speed with feedback control to regulate the water flow through the unit.

37. Display Panel

The display panel can be mounted to the unit or in a different location. It houses the display and the system control board.

38. Water Manifolds

The inlet and outlet water manifolds allow for connecting multiple units in series.

39. Flush Valves

Flush valves are on both the inlet and outlet to allow for cleaning the condenser and the pump is also included on the inlet line.

Model 60K

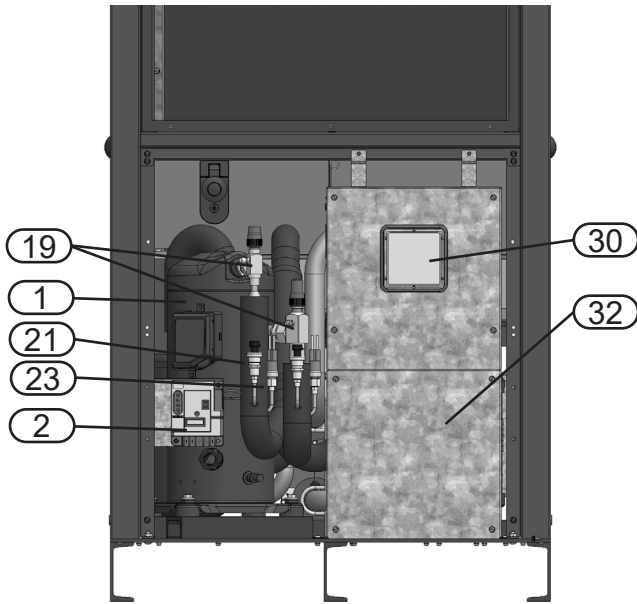

Front View (with lower panel removed) - Model 60K

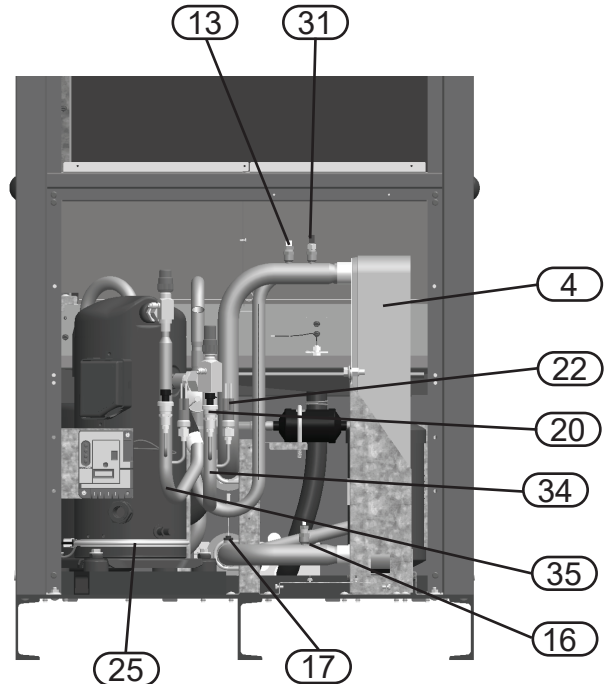

Front View (with lower panel & control panel removed) - Model 60k

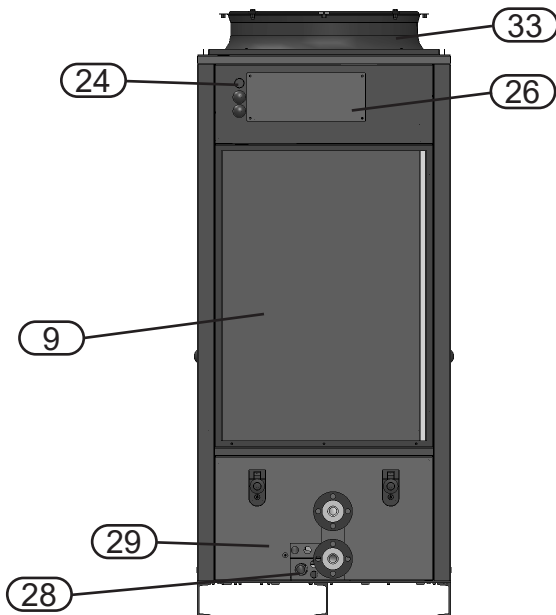

Rear View (HEX grill removed) - Model 60K

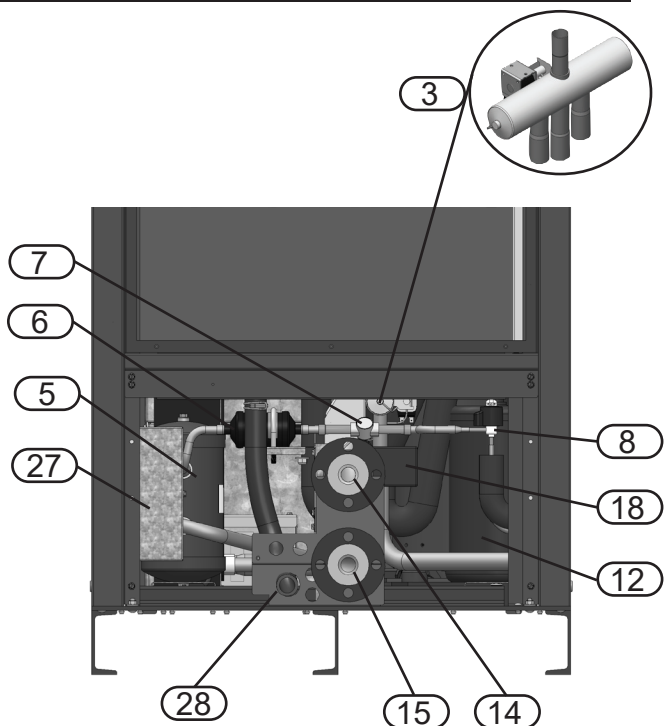

Rear View (lower rear panel removed) - Model 60K

The Air Source Heat Pump Water Heater - How it works...

Model 60K

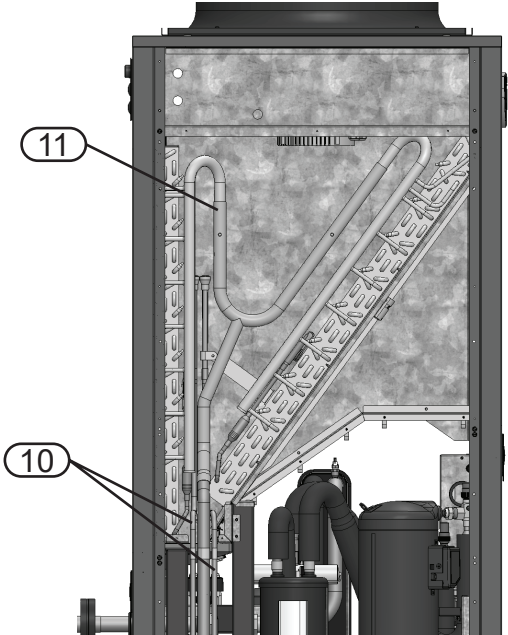

Left Side (inside unit) - Model 60k

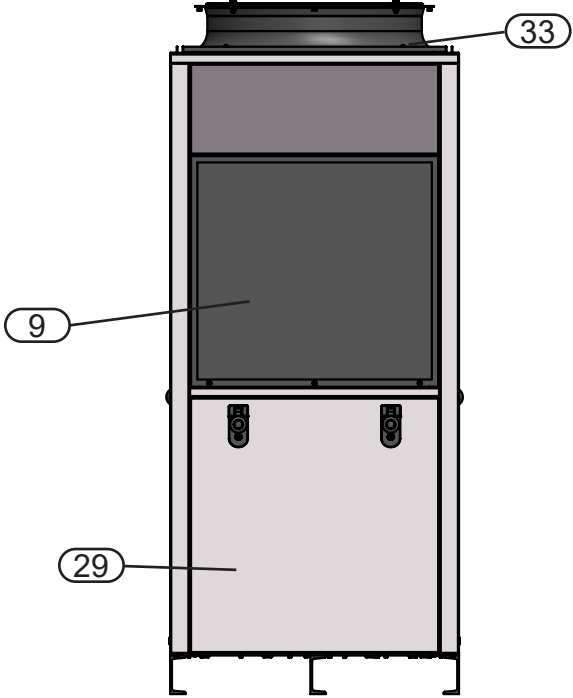

Front View (HEX grill removed) - Model 60k

2000630399 00

Model 140K

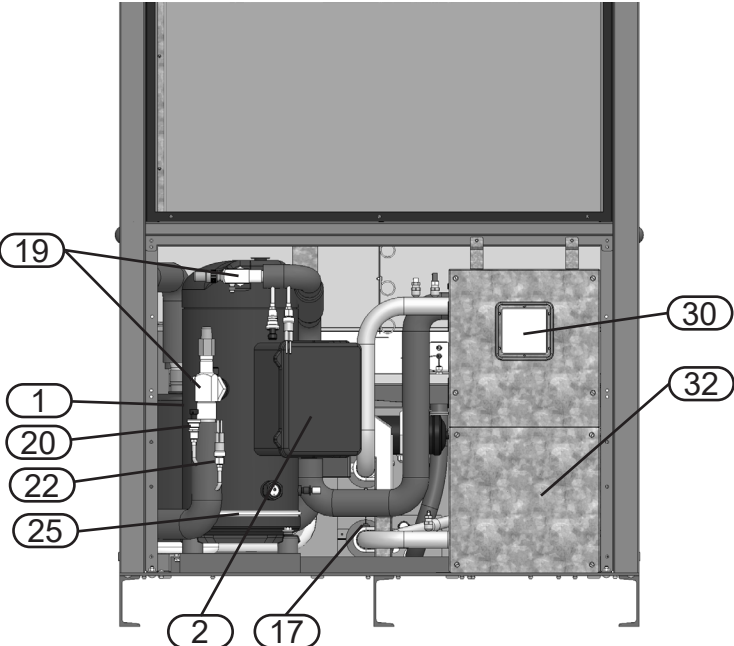

Front View (with lower panel removed)- Model 140K

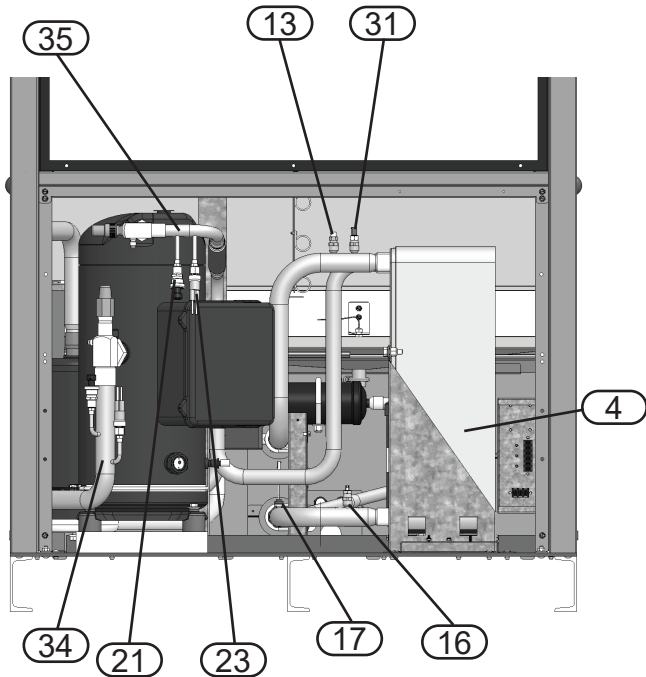

Front View (with lower panel & control panel removed)- Model 140k

The Air Source Heat Pump Water Heater - How it works...

Model 140K

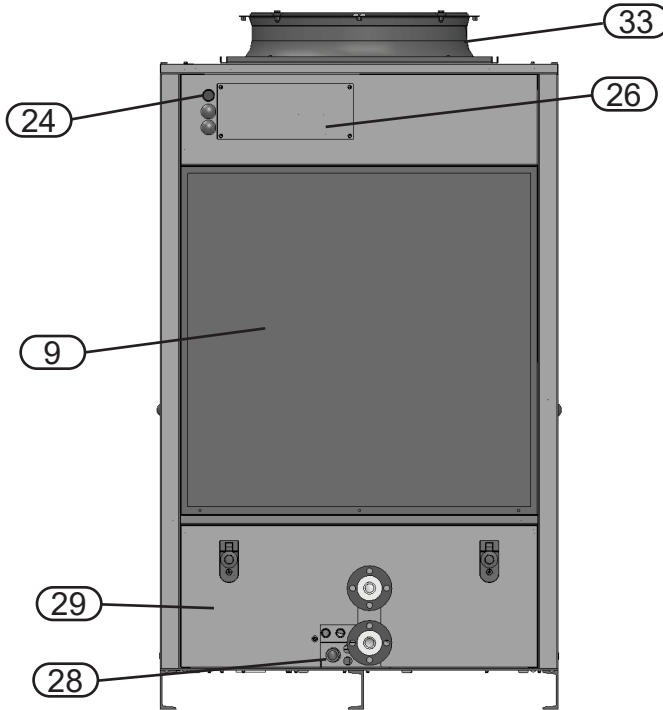

Rear View (HEX grill removed) - Model 140K

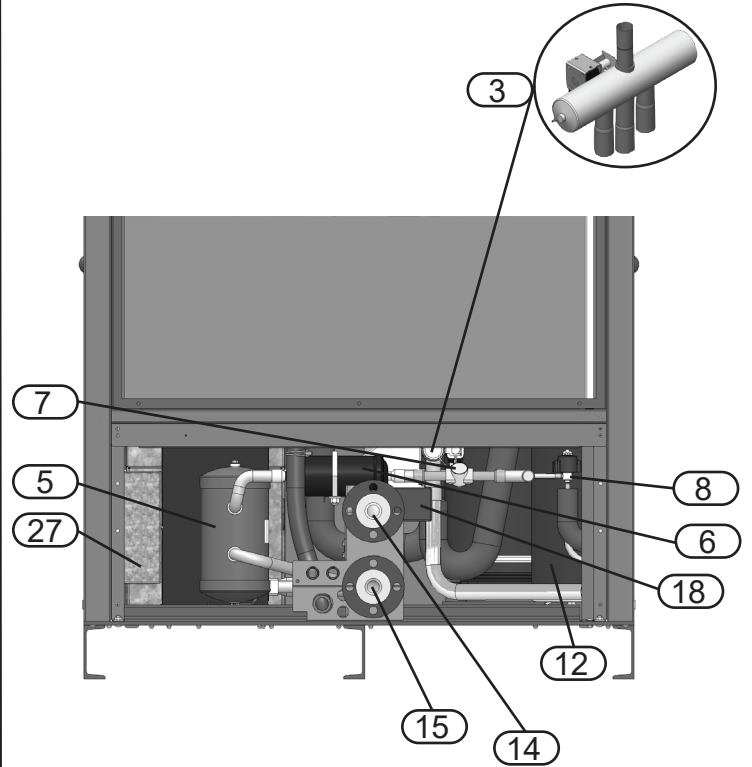

Rear View (lower rear panel removed) - Model 140K

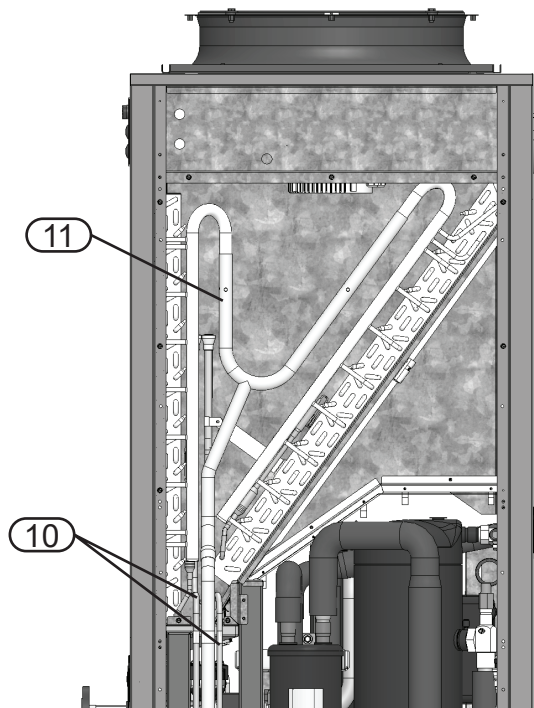

Left Side (inside unit) - Model 140k

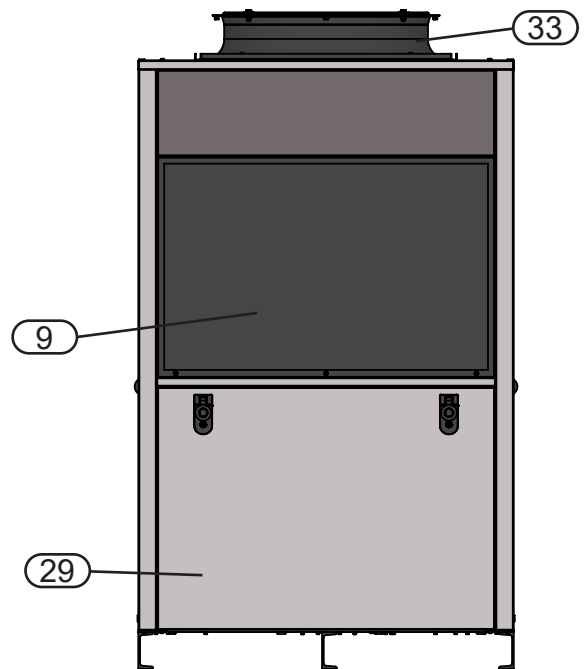

Front View (HEX grill removed) - Model 140k

2000630370 00

The Air Source Heat Pump Water Heater - How it works...

Manifold

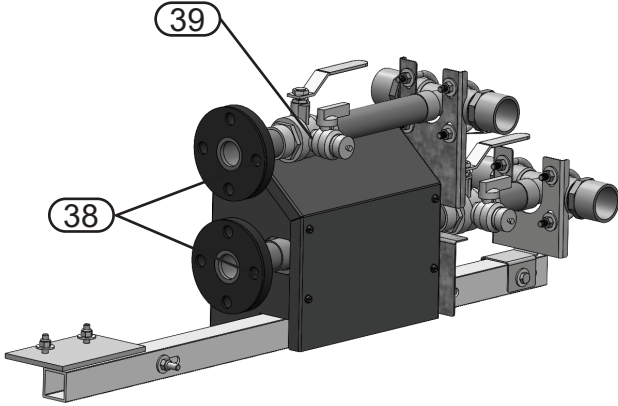

With Pump Cover

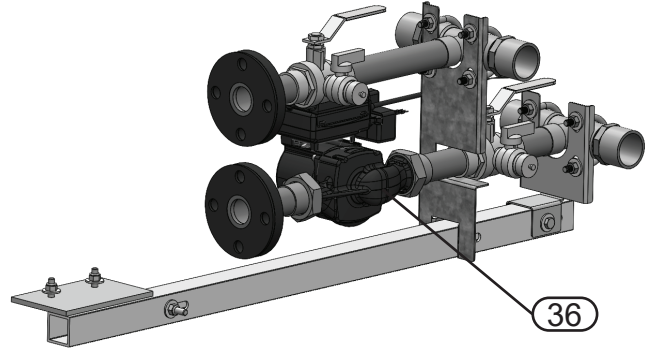

Without Pump Cover

Display Box

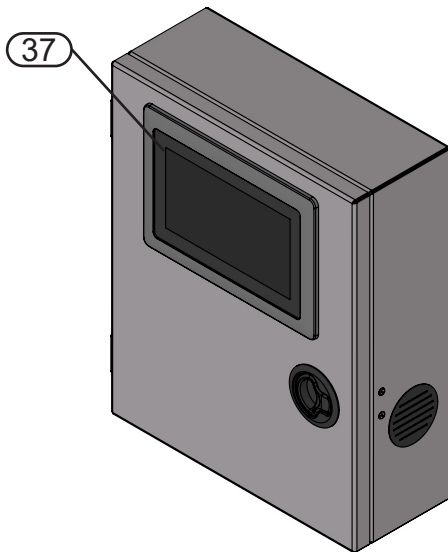

2000630397 00

Display Panel

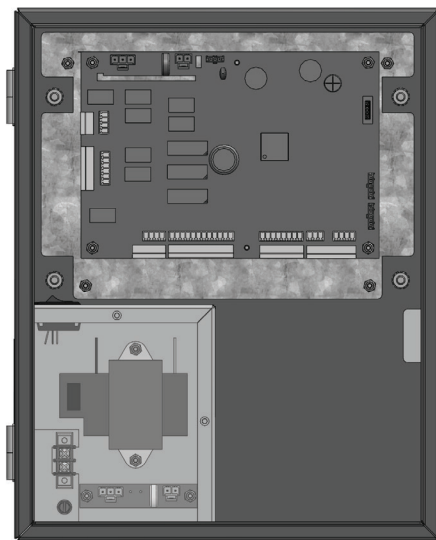

Inside Display Panel

The Air Source Heat Pump Water Heater - How it works...

PRINCIPLE OF OPERATION

The units covered by this Instruction Manual are commercial air to-water heat pump water heaters (HPWH).

HPWH's remove heat from air forced through evaporators and transfer it to refrigerant. The refrigerant is compressed which increases temperature. The high pressure high temperature refrigerant passes through a condenser to heat the water also passing through the condenser.

THE REFRIGERATION CYCLE

Refrigerant is circulated through the refrigeration circuit by a compressor. The refrigerant is a high temperature high pressure gas when it leaves the compressor. Refrigerant flows from the compressor through the 4 way valve to the condenser.

The condenser is a refrigerant-to-water heat exchanger with two circuits. Refrigerant flows through one circuit and water through the other. The high temperature refrigerant gas transfers its heat to the water flowing through the condenser. As the refrigerant gas cools inside the condenser it changes state (condenses) from a gas to a liquid. An integrated hot water circulator pump is provided from the factory, this pump circulates water through the condenser.

Refrigerant leaving the condenser is a medium temperature high pressure liquid. It flows through the liquid line to the receiver, then the filter drier, sight glass, and finally the electronic expansion valves (EEVs). The EEV controls the flow of the liquid/vapor mixture which helps to ensure all of the refrigerant is in a gaseous state by the time it exits the evaporator to protect the compressor. The evaporator is a tube-and-fin constructed coil. It is an air-to-refrigerant heat exchanger with refrigerant flowing through the tubes and air flowing across the fins.

The fan moves ambient air from the installed space or air ducted to the HPWH from another location across the fins of the evaporator coil. The refrigerant absorbs heat from the air in the evaporator. The refrigerant changes state (boils/evaporates) from a liquid/vapor state back into a gas (vapor) in the evaporator.

The refrigerant flows out of the evaporator through the line to the four way valve and into the accumulator. The accumulator traps any liquid refrigerant the evaporator is unable to vaporize during low temperature operating conditions. The accumulator prevents liquid refrigerant from entering the compressor where it could damage internal components.

Low temperature low pressure refrigerant gas (vapor) is drawn out of the accumulator by the compressor. The compressor increases the pressure and temperature of the refrigerant gas, circulating it to the condenser again where the refrigeration cycle starts over or continues.

Normal Operation

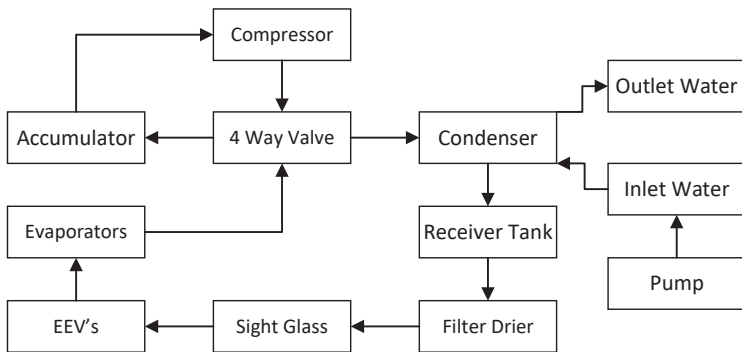

Defrost Operation

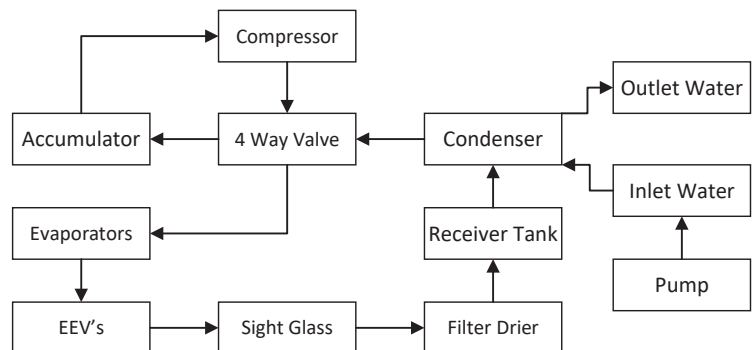

The Air Source Heat Pump Water Heater - How it works...

AIR TEMPERATURE RANGE

The entering air temperature operating range for the HPWH is 23°F to 120°F (-5°C to 49°C).

When the HPWH is operating properly the air temperature drop through the evaporator heat exchanger will be approximately 12°F to 20°F (7°C to 12°C).

WATER TEMPERATURE RANGE

The inlet/entering water temperature operating range for the HPWH is 40°F to 140°F (4°C to 60°C). The HPWH will heat potable water up to 160°F. When the HPWH is operating properly the water temperature rise through the condenser (heat exchanger) will vary based on water flow and ambient temperatures.

REFRIGERANT CHARGE

The HPWH is factory-charged with R-513A refrigerant. The refrigerant charge is weighed in at the factory. It should not be necessary to add or remove refrigerant during installation, startup, or service.

STORAGE RECOMMENDATIONS

The HPWH units can be stored indoors or outdoors. Do not stack units or stack other construction materials on the units while in storage.

The HPWH units contain electrical/electronic components and should only be stored in conditions between -20°F to 120°F (-29°C to 49°C) and 5 to 95 percent relative humidity. Electrical components are not moisture-tolerant.

Note: The limited warranty does not cover damage to the unit or controls due to negligence during storage.

EQUIPMENT DISPOSAL

This heat pump water heater contains R-513A refrigerant and is regulated as a stationary refrigeration appliance under Section 608 of the Clean Air Act. Disposal of this unit must be performed in accordance with the provisions in Section 608 of the Clean Air Act and any state or local regulations that may also apply.

Performance



LOW LEAD CONTENT

Model Number	Water Flow Rate in GPM (Single Pass)	Performance ²		Air Volume (CFM)	Water Connection
		Heating Capacity BTU/hr	COPh		
060	2.69	66,688	4.61	1543.95	1-1/2 NPT
140	5.22	136,381	4.27	5102.25	1-1/2 NPT
200 ¹	7.91	203,069	4.44	6646.20	1-1/2 NPT
280 ¹	10.44	272,762	4.27	10204.50	1-1/2 NPT
350 ¹	13.13	339,450	4.44	11748.45	1-1/2 NPT

NOTES:

1. Models 200 through 350 are composed of combinations of models 60 and 140 which are the certified units.
2. Performance rated at 80.6°F ambient temperature with 63% relative humidity; Inlet water at 70° ± 1°F, Outlet water at 120°F ± 5°F.
3. Supply Voltage - 480V/3-phase 60 Hz
4. Variable fan speed across different ambient temperatures.

NOTICE

Maximum allowed working pressure on a refrigeration circuit:
 High side - 347 psi
 Low side - 61 psi
 Maximum water pressure - 175 psi

The table above lists performance information on 5 unit sizes. These sizes are based on combinations of the 2 smaller models, 060 and 140. The table below shows the combination of models needed to get the desired model performance.

Desired Model Performance	Combination of Models
200	060 + 140
280	140 x 2
350	(140 x 2) +060

NOTICE

The heat pump water heaters are intended for use at altitudes of 2000 meters and below.

When servicing this unit, verify the power to the unit is turned off prior to opening the control cabinet door.

1 Determine Water Heater Location

Installation must comply with:

- Local, state, provincial, and national codes, laws, regulations, and ordinances.
- National Electrical Code.
- For Canada only: B149.1 Installation Code, CSA C22.1 Canadian Electrical Code Part 1 and any local codes.

NOTICE

The Air Source Heat Pump Water Heater meets safety test requirements under UL-60335-2-40 – latest edition.

Read all installation requirements in this manual before installation begins.

Costs to diagnose, perform service, and repair damage caused by installation errors are not covered under the limited warranty.

Costs to correct installation errors are not covered under the limited warranty. Before locating the water heater, check:

1. Check for nearby connection to:
 - Water piping
 - Ducting Options
 - Electrical Power
2. Locate the appliance so that if water connections should leak, water damage will not occur. When such locations cannot be avoided, it is recommended that a suitable drain pan, adequately drained, be installed under the appliance. Under no circumstances is the manufacturer to be held responsible for water damage in connection with this appliance, or any of its components.
3. Check area around the water heater. Remove any corrosive materials.
4. If a new water heater will replace an existing water heater, check for and correct system problems, such as system leaks causing oxygen corrosion or heat exchanger cracks from hard water deposits.

CAUTION

PROPERTY DAMAGE!

- All water heaters may eventually leak.
- Do not install without adequate drainage.

5. Check around the water heater for any potential air contaminants that could risk corrosion to the water heater (see Table 1-3 on page 19). Remove any of these contaminants from the water heater area.

DO NOT install units in rooms or environments that contain corrosive contaminants. Failure to comply could result in severe personal injury, death, or substantial property damage.

Indoor/Outdoor Installations (Milder Climates)

Choose a location for optimal performance and safety.

The HPWH should be located in an area where leakage from the HPWH or system will not result in property damage.

Freezing temperatures

The HPWH unit can be installed in space where freezing temperature will occur, and is programmed to cycle the pump to keep water flowing. Heat tape is also installed on the drain pan, condenser, and water inlet and requires power to the unit. Damage caused by exposure to freezing temperatures is not covered under the limited warranty.

Coastal regions

The exterior materials and components supplied on the HPWH have been tested, and passed the requirements for UL 60335-2-40.

Indoor

When installed indoors it may be necessary to duct HPWH outlet air out of the space to prevent over cooling of the room which will prevent optimal performance of the water heater.

Ducting air into the water heater may be necessary to maintain a sufficient air supply to run the unit.

Heat source

The HPWH unit should be located where there is an adequate source of ambient heat and where the cooling benefit can be utilized when possible. If installation in a space with an adequate heat source is not possible the HPWH unit can be ducted to/from another space such as a boiler room or to the outdoors where sufficient heat is available.

1 Determine Water Heater Location *(continued)*

Clearances:

1. Recommended clearances for service access, ducting or air flow from the top of the unit is 48 inches.
2. To ensure optimal performance a minimum of 36 inches clearances required from the back, and front of the HPWH unit and any wall obstruction. When installed on an equipment pad the HPWH must be level.

Front / Rear 36"
 Top 48"

NOTICE Multiple appliances can be installed side by side with no clearances between adjacent appliances because the appliances are approved for zero clearances; however, service access will be limited from the sides. Consult with the local inspection authority for approval.

NOTICE If you do not provide the recommended service clearances shown, it may not be possible to service the appliance without removing it from the space. These clearances are also needed for adequate air flow.

Figure 1-1 Minimum Required Clearances

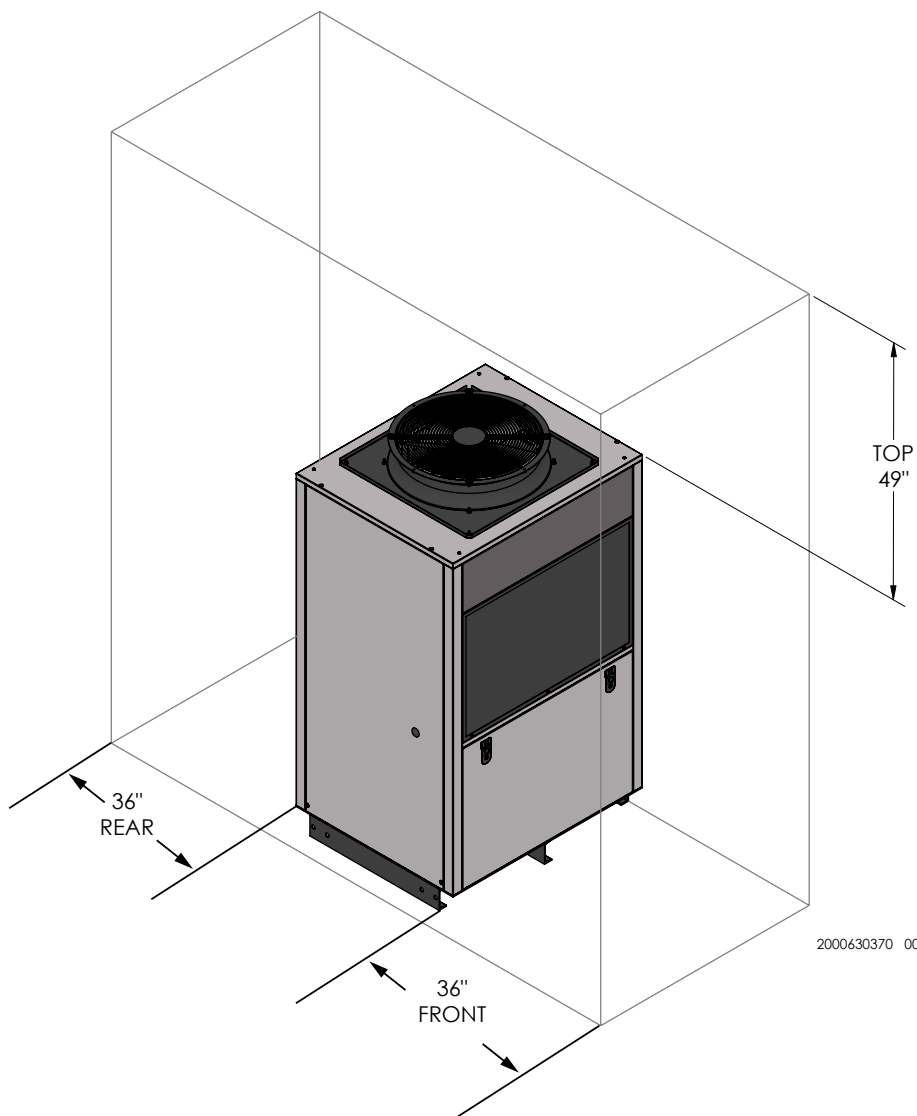

1 Determine Water Heater Location

Provide air openings to room:

Water heater alone in equipment room

Conditioned space

When installed in a conditioned space ducting supply (outlet) air to an alternate location may be necessary to avoid overcooling of the space where the HPWH is installed or provide spot cooling in areas for comfort and/or to off set cooling load. See Air Flow and Ducting starting on page 36.

Unconditioned space

When installed in an unconditioned space ducting return (inlet) air from an alternate location may be necessary to access an adequate or greater source of heat for optimal efficiency. See Air Flow and Ducting starting on page 36.

Flooring and foundation:

Flooring

The HP is approved for installation on floors that are level and structurally sound to support the weight of the unit.

WARNING Do not install the water heater on carpeting even if foundation is used. Fire can result, causing severe personal injury, death, or substantial property damage.

If flooding is possible, elevate the water heater sufficiently to prevent water from reaching the water heater.

Seismic bracing

For installations requiring seismic bracing, the base legs of the appliance are designed to allow for the use of mounting brackets to meet seismic requirements. Consult the factory.

Vent and air ducts

The water heater requires a special vent system, designed for pressurized venting. Consult the factory.

Air Temperature

Entering air temperature

The return (entering) air temperature range of operation for the unit is 23° - 120°F (-5°C to 49°C). The air temperature drop (Delta T - ΔT) through the evaporator (heat exchanger) will be approximately 12°F to 20°F (7°C to 12°C).

If the entering air temperature is outside this operating range the HPWH unit discontinues heating operation until the entering air temperature returns to this operating range.

Electrical requirements

Ensure the power supply voltage and phase at the job site matches the power supply ratings listed on the HPWH data rating label BEFORE INSTALLATION BEGINS.

The installation must conform with these instructions and the local code authority having jurisdiction and the requirements of the power company. In the absence of local codes, the installation must comply with the current editions of the National Electrical Code, ANSI/NFPA 70 or the Canadian Electrical Code CSA C22.1.

Voltage applied to the HPWH should not vary more than +6% to -6% of the voltage requirement listed on the HPWH rating label for satisfactory operation.

Minimum circuit ampacity & maximum fuse size

Use MCA to select the minimum field wires size to power the unit and MFS to select the maximum fuse size for over current protection as follows:

$$MCA = C \times 1.25 + M + P$$

$$MFS = C \times 2.25 + M + P$$

Where:

C - Compressor RLA

M - Blower Motor FLA

P - Pump FLA

Table 1-1 Voltage & Amperage Ratings (single units)

Model	Volts/Phase/Hz	COMPRESSOR			FAN MOTOR		PUMP	RLA: Rated Load Amps FLA: Full Load Amps HP: Horse Power MCC: Maximum Continuous Current All shown MFS Values are rounded up to the nearest common fuse size.
		RLA	MCC	HP	FLA	HP	FLA	
060	440-480/3/60	13.0	14.2	6.0	2.5	2.0	1.4	
140	440-480/3/60	28.0	35.0	13.0	2.5	2.0	1.4	

Fuses supplied with the unit and tested are time delay fuses.

1 Determine Water Heater Location *(continued)*

Table 1-2 Voltage & Amperage Ratings

Model	Volts/Phase/Hz	FLA
060	440-480/3/60	16.9
140	440-480/3/60	31.9
200	440-480/3/60	48.8
280	440-480/3/60	63.8
350	440-480/3/60	80.7

Note: Amp draws are calculated from base units 060 and 140 in combinations listed on page 15.

Table 1-3 Corrosive Contaminants and Sources

Products to avoid:
Spray cans containing chloro/fluorocarbons
Permanent wave solutions
Chlorinated waxes/cleaners
Chlorine-based swimming pool chemicals
Calcium chloride used for thawing
Sodium chloride used for water softening
Refrigerant leaks
Paint or varnish removers
Hydrochloric acid/muriatic acid
Cements and glues
Antistatic fabric softeners used in clothes dryers
Chlorine-type bleaches, detergents, and cleaning solvents found in household laundry rooms
Adhesives used to fasten building products and other similar products
Areas likely to have contaminants
Dry cleaning/laundry areas and establishments
Swimming pools
Metal fabrication plants
Beauty shops
Refrigeration repair shops
Photo processing plants
Auto body shops
Plastic manufacturing plants
Furniture refinishing areas and establishments
New building construction
Remodeling areas
Garages with workshops

CAUTION

CORRECT POWER SUPPLY!

- Ensure the power supply at the job site matches the voltage and phase listed on the HPWH rating label before connecting power to the HPWH unit.
- Energizing the HPWH with the wrong voltage or phase will cause permanent damage to the HPWH unit.
- Damage caused to the HPWH as the result of applying the wrong voltage or phase is not covered under the limited warranty.

Minimum Wire Size

Allowable Ampacities of Insulated Conductors

Three-phase heaters are three wire circuits. In addition to the foregoing, a grounded conductor is required. Not more than three conductors in raceway, cable, or earth (directly buried), based on ambient temperature of 30°C (86°F).

⚠ WARNING

Electrical Shock Hazard



- Before removing any access panels or servicing the water heater, make sure the electrical supply to the water heater is turned "OFF."
- Failure to do this could result in death, serious bodily injury, or property damage.

2 Prepare water heater

Remove water heater from wood pallet

1. After removing the outer shipping carton from the water heater, remove the parts box.
2. To remove the water heater from the pallet remove the four (4) lag bolts located at the front and rear of the unit (FIG. 2-1).

NOTICE

Do not drop the water heater or bump the jacket on the floor or pallet. Damage to the water heater can result.

Figure 2-1 Water heater mounted on shipping pallet

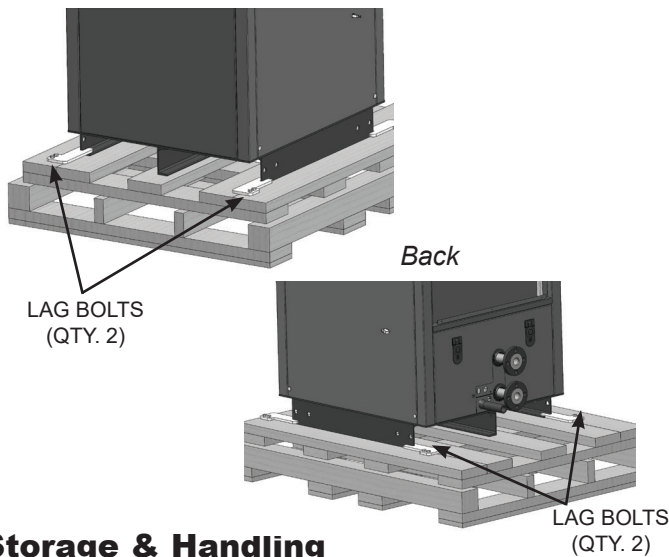

Storage & Handling

The heat pump water heaters covered in this manual are stationary refrigeration appliances. Careful handling is necessary to prevent internal damage.

1. Do not tilt the unit more than 45 degrees in any direction from the vertical position. All internal components are braced from the base of the unit. Tilting may compromise the refrigeration piping inside the unit and cause refrigerant leaks.
2. Do not remove the cover or deface any permanent instructions, wiring diagrams, labels, or the rating label for the outside cabinet or inside panels on the HPWH unit.
3. Do not hoist the unit with chains or straps unless spreader bars are furnished. The side panels and top of the unit are not constructed to handle significant force from the sides or above. Failure to use spreader bars when lifting can cause damage to the unit.
4. When lifting the heat pump with a crane, use appropriate straps and rigging. Lifting straps should be long enough that the angle between the strap and unit is no less than 45 degrees (see figure 2-5). Lifting from another location could result in deformation and failure of sheet metal structure.

5. The HPWH unit is heaviest on the compressor side (left side when facing the front of the unit). The weight of an 140 is 847 lbs. and the weight of an 60 is 671 lbs. See Figures 2-2 and 2-3 for unit dimensions and approximate location of the center of mass.
6. Before lifting or moving the heat pump with a forklift, remove the front and rear jacket panels to avoid damage to the panel tabs. When using a forklift to raise the HPWH unit ensure the forks are positioned correctly between the runners on the bottom of the HPWH unit. See Figure 2-6.
7. The HPWH unit must be lifted from the front side only when using a forklift to raise the unit. See Figure 2-6.

Figure 2-2 Center of gravity for 60k heat pump

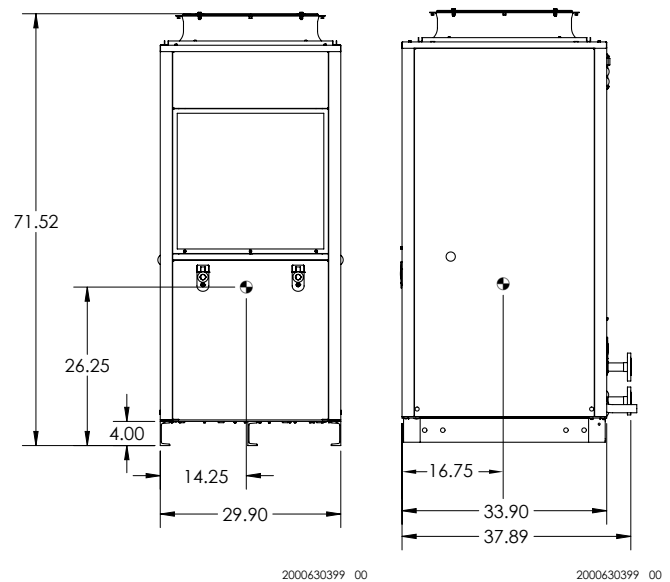
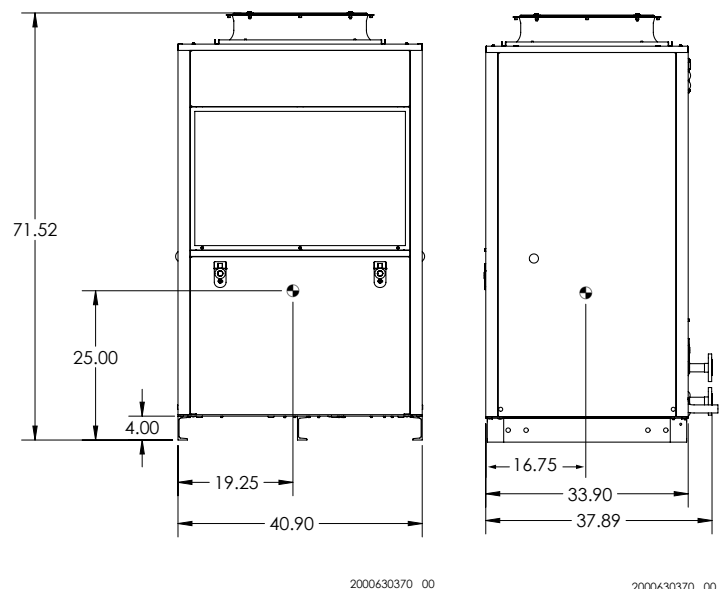

Figure 2-3 Center of gravity for 140k heat pump



2 Prepare water heater *(continued)*

Figure 2-4 Remove lower front and rear panels before lifting unit

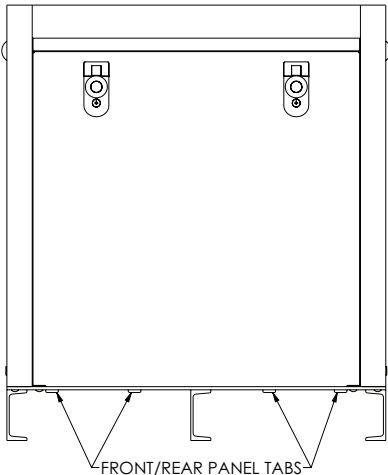

Figure 2-5 Appropriate lifting strap angles

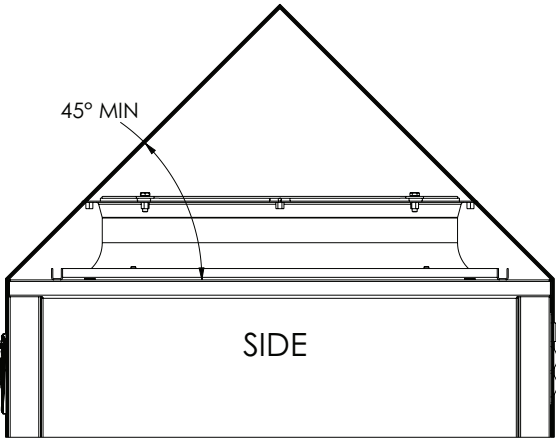
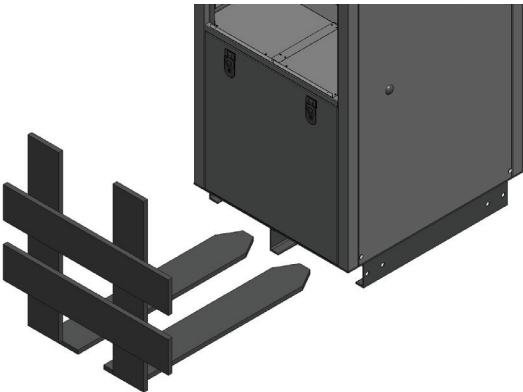

Figure 2-6 Water heater and forklift fork position



Assemble water manifold

The inlet and outlet manifolds are located in the parts box along with the mounting bracket and hardware. Figure 2-8 shows the manifold assembled and connected to the base.

Figure 2-7 Manifold parts recieved in kit

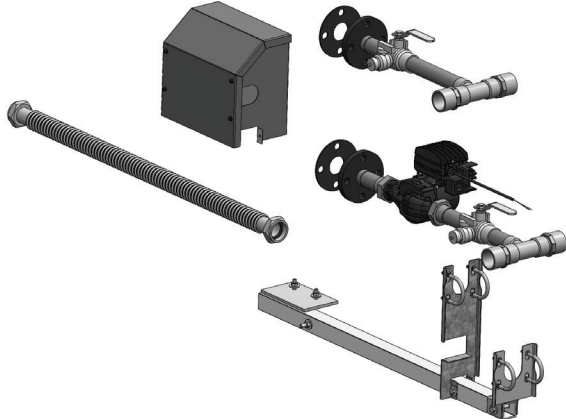

Figure 2-8 Single Manifold Assembly

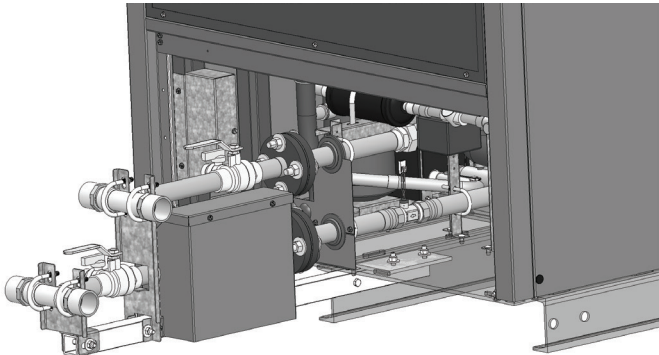
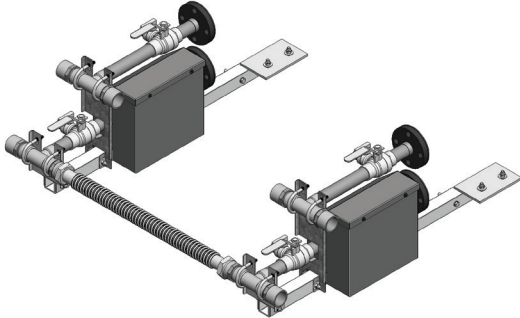

Figure 2-9 Multi-Manifold Assembly



3 Installing water heater

Required Ability

Installation and service of the HPWH unit requires ability equivalent to that of a qualified agency in the field involved. Plumbing, ducting and electrical work are required.

See Installer Qualifications on page 6.

General

The installation must conform with these instructions and the local code authority having jurisdiction. In the absence of local codes, the installation must comply with the latest editions of the National Electrical Code, ANSI/NFPA 70 or the Canadian Electrical Code CSA C22.1. The National Electrical Code may be ordered from: National Fire Protection Association, 1 Batterymarch Park, Quincy, MA 02269. The Canadian Electrical Code is available from the Canadian Standards Association, 8501 East Pleasant Valley Road, Cleveland, OH 44131.

DO NOT start the HPWH unit or test the electrical system before it is connected to the water system, purged of air and filled with water. See Start Up on page 46.

See pages 8-12 to identify the principal components of the HPWH.

Required Tools & Materials

Installation & Start-up Tools

- All tools common to installation and service of commercial electric water heaters such as hand tools, pipe cutter and torch.
- Heat transfer compound (paste).
- Electrical switch lock out device - used to secure disconnect switches/breaker panels while servicing.
- Electronic thermometer including:
 - Four (4) thermocouple sensors capable of measuring surface temperatures on water or refrigerant piping up to 2 inch diameter.
 - Two (2) thermocouple sensors capable of measuring ambient air temperature.
 - Temperature range 32°F - 210°F (0°C - 100°C).
- Volt-Ohm Multi Meter - capable of measuring:
 - AC Voltage up to 600 VAC.
 - DC Voltage up to 24 VDC.
 - Ohms up to 2,000,000 ohms.
 - Continuity.
- AC amp meter - capable of measuring:
 - AC amperage up to 200 amps.
- Calculator.

Service Tools

See Installer Qualifications on page 6 regarding regulations and certifications required under Section 608 of the Clean Air Act before servicing the refrigeration circuit.

- Refrigeration manifold gauges.
- Refrigeration charging scale.
- Refrigeration vacuum pump.
- Refrigerant recovery machine.
- Refrigerant reclamation storage tank.

Unit Placement

Whether replacing existing water heating equipment or installing the HPWH in new construction, the following critical points must be observed: The HPWH unit:

- Should be installed near a floor drain for condensate removal.
- The HPWH, storage tank and water heater(s) should be located in an area where leakage will not result in damage to adjacent area or to lower floors in the building structure.
- The HPWH unit must be level for proper condensate drainage. Shim the channel type skid base, pad or floor as necessary if leveling is required.
- Should be installed close to the point of major hot water usage and power supply.
- Should be located so that hot water piping and branch circuit wiring will be as short as possible.

Mounting Frame

The mounting frame must support the length, width, and weight of the HPWH unit. The weight of the HPWH unit must be evenly dispersed across the footing channels on the bottom of the unit.

NOTE: A qualified engineer should design and size the structural components of the mounting frame. Structural channels in a field-provided frame should be mounted in line with each of the unit base channels.

Pad Mounting

The HPWH may be pad mounted. Vibration isolator mounts **MUST BE** placed between the unit and the equipment pad to prevent mechanical vibration transmitting into the building structure. Selection of appropriate vibration isolators should be made by a qualified engineer. Unit must be level.

Display Panel Mounting

The display panel can be mounted to either side of the unit or in an equipment room that is no more than 400m away from the heat pump.

To mount the display to the side of the unit, the unit mounting bracket should be fastened to top of the unit using the screws provided. The bracket should be located one inch away from the center of the plugged hole on top of the unit. Once the bracket is attached, there are four holes on the back panel of the box. Fasten the four sheet metal screws provided through the back, bracket, and side panel to secure the display panel in place.

3 Installing water heater *(continued)*

Figure 2-10 Display Panel Mounting on the Unit

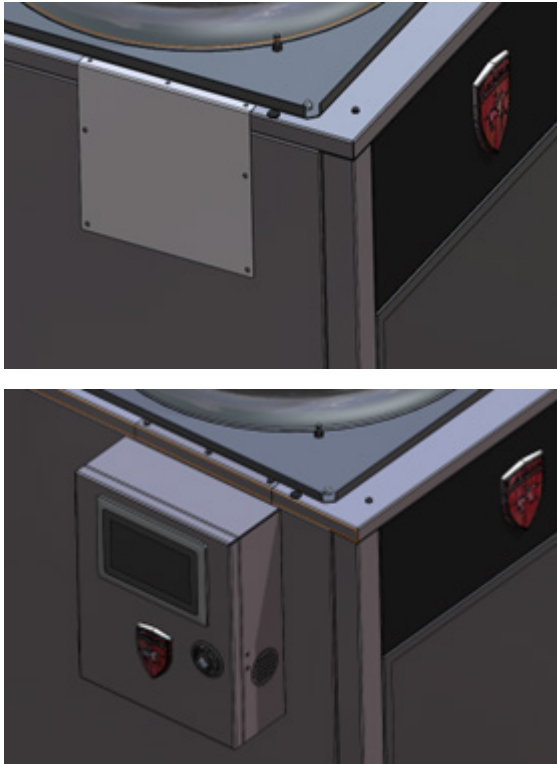

Electrical Connections

Correct Voltage and Phase

Ensure the power supply voltage and phase at the job site matches the power supply ratings listed on the HPWH rating label BEFORE INSTALLATION BEGINS.

Voltage applied to the HPWH should not vary more than +6% to -6% of the voltage requirement listed on the HPWH rating label for satisfactory operation.

Energizing the HPWH with the wrong voltage and/or phase may cause permanent damage to HPWH components. Damage resulting from applying the wrong power supply voltage or phase to the HPWH is not covered under the limited warranty.

Branch Circuit Disconnect Switch

The power supply wiring and equipment grounding must be installed in accordance with local codes or, in the absence of local codes, the National Electrical Code, ANSI/ NFPA 70 or the Canadian Electrical Code, CSA C22.1.

Install an adequately fused disconnect switch as close to the units as possible. See unit rating label for maximum fuse size (MFS).

Run the power supply lines from the disconnect to the control box at the top back panel of the unit. Connect the lines to the terminals on input side of power distribution block L1, L2 & L3 for three phases. Connect ground wire to ground lug. If out of phase the HPWH will shut down and display error.

⚠ WARNING	
	Electrical Shock Hazard
	<ul style="list-style-type: none"> • Before removing any access panels or servicing the water heater, make sure the electrical supply to the water heater is turned "OFF." • Failure to do this could result in death, serious bodily injury, or property damage.

Water Connections

Water piping must be installed in accordance with the instructions in this manual and all local plumbing codes having jurisdiction. See Piping Diagrams on pages 28-35 as a reference for these instructions.

Installation Instructions

1. This HPWH unit is not designed to supply hot water directly to hot water fixtures. The HPWH unit must be installed with separate storage tanks as shown in the water piping diagrams in this manual.
2. Water lines installed between the storage tank and the HPWH unit MUST NOT be less than the water pipe connection sizes on the unit. See Figures 4-2 thru 4-9 on pages 28-35.
3. The HPWH should be plumbed directly to the storage tanks.
4. The cold water supply can be connected into the heat pump inlet manifold or lowest tank connection.
5. The outlet (supply) water from the HPWH unit should connect to the inlet connection on the storage tank, and should be located above the inlet connection.
6. The inlet (return) water entering the HPWH should connect to the inlet connection on the storage tank lower than the tank outlet connection.
7. A T&P valve must be installed in the designated opening on the storage tank per the tank manufacturer's requirements. See Temperature - Pressure Relief Valve on page 26.
8. For optimal performance minimize the equivalent length of water piping between the HPWH and storage tank.
9. Building hot water recirculation loop should be connected to the inlet of the backup water heater on two tank preheat configurations or to the storage tank on single tank configurations. The recirculating pump MUST BE controlled by a field supplied thermostat installed in the building recirculation return line near the storage tank or back up heater. The thermostat should stop pump operation the moment the recirculation line is hot.

3 Installing water heater

10. Do not use check valves between the heat pump outlet and tank unless required by code on the system diagrams. Internal ball valves can prevent hot water short circuiting.
11. Water lines shared by parallel HPWH units must be large enough to handle combined water flows. Flow rates through the heat pumps and tank(s) must be balanced.
12. All components in the hot water supply system must be adequately sized to meet peak water flow requirement
13. When the HPWH unit is installed above the storage tank install a tee fitting at a high point in the outlet water line leaving the unit. Install a purge valve, or if required by local code, a T&P valve (temperature and pressure relief) in a branch of the tee fitting that can be used to purge air from the HPWH unit during start up.
14. DO NOT install a (T&P) relief valve in the outlet line of the HPWH unit unless required by local code.
15. Dielectric unions should be installed at the inlet and outlet water lines to the HPWH unit.
16. All HPWH water piping must be insulated.

Single Tank Configuration

The HPWH must be plumbed to storage tank. The maximum stored water temperature the HPWH unit can produce in the storage tank is 160°F (71°C). Tank ports must be large enough to handle the peak water flow rates through the water heating system. See Piping Diagrams on pages 28-35 for detailed piping diagrams.

Multiple Tank Pre-heat Configuration

When water temperatures above 160°F (71°C) are required the HPWH and storage tank are piped in series (upstream) with a backup water heater. See Water Temperature on page 11. The backup water heater will raise the temperature of the preheated water to the final system temperature required.

Figure 3-1 Condensate trap

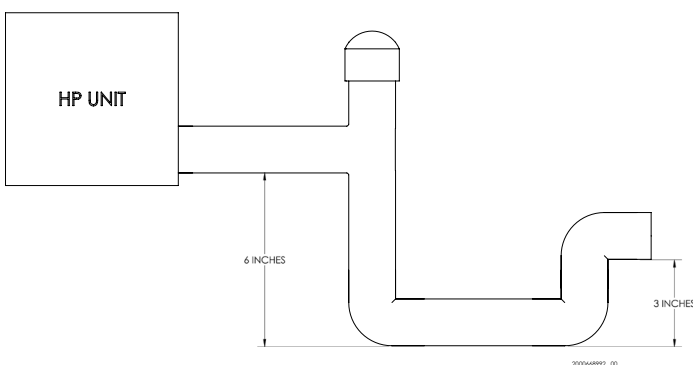

Condensate Drain Line

The HPWH unit must be plumbed to permit condensate drainage. Drain piping connected to the HPWH unit should be a minimum 1 inch PVC or equivalent. A condensate trap must be used to overcome the internal vacuum to permit proper drainage. See Figure 3-1 for recommended drain trap dimensions.

The condensate must be discharged to a suitable drain. If a drain is inaccessible, use a condensate pump.

NOTICE

Drain trap must be flooded to prevent water from backing up into the drain pan

Standard Tank Thermostat

Standard tank thermostats already installed in the storage tank may be used. Ensure the standard tank thermostat is installed the lower third of the tank. Wire the existing tank thermostat to the system control board.

Water Temperature

Maximum System Temperature

The HPWH units covered in this manual are capable of maintaining a maximum system/storage tank temperature of 160°F (71°C). Some commercial water heating applications may require higher temperatures. Install a booster water heater downstream from the storage tank for temperatures above 160°F (71°C).

Inlet & Outlet Water Temperature

The inlet (entering) water temperature operating range for the HPWH is 40°F to 140°F (4°C to 60°C). The water temperature rise (Delta T - ΔT) through the condenser (heat exchanger) will be vary dependent on water flow and ambient temperature from 8°F to 120°F (5°C to 75°C).

Outlet water temperatures up to 160°F (71°C) are possible during normal operation. Exposure to water temperatures this high can cause serious bodily injury or death. See Mixing Valves and Table 4-1 on page 26.

Service & Installation Notes:

If the inlet (entering) water temperature is outside the operating temperature range for extended periods the control system may lock out on high or low refrigerant pressure switch events/trips.

When the control system locks out on a refrigerant pressure switch event, the compressor and fan will stop running. The pump will be powered but may not run. For the high pressure switch, this is a hard lock out condition. For the low pressure switch, this is an auto-reset lockout. The control system is manually reset by cycling power to the HPWH off and then on again or by pressing the button on the side of the control panel.

The tank thermostat must not be set any higher than 160°F (71°C) to prevent control system lock outs.

4 System Piping

Read all installation requirements in this manual before installation begins.

The water piping installation must conform to these instructions and to all local and national code authority having jurisdiction.

Costs to diagnose, perform service and repair damage caused by installation errors are not covered under the limited warranty.

Costs to correct installation errors are not covered under the limited warranty.

System water piping methods

Observe a minimum of 1/4 inch clearance around all un-insulated hot water pipes when openings around the pipes are not protected by non-combustible materials.

Water connections

The inlet and outlet water connections on the 60- 140 models are 1-1/4 flange, but the manifolds provided are 1-1/2 NPT.

General Piping Information

Basic steps are listed below along with illustrations on the following pages (FIG. 4-2 thru 4-9), which will guide you through the installation of the water heater.

1. Connect the manifold mounting bracket to the back of the unit.
2. Connect the inlet manifold to the inlet side of the water heater with pump connected.
3. Connect the outlet manifold to the outlet side of the water heater.
4. Connect the cold water supply to the inlet side of the water heater.
5. Connect the hot water supply to the outlet side of the water heater.
6. Install a back flow preventer on the cold feed makeup water line.
7. Install an expansion tank on the system supply. Consult the tank manufacturer's instruction for specific information relating to tank installation. Size the expansion tank for the required system volume and capacity.
8. Install a drain valve at the lowest point of the system.
9. Install field supplied relief valve to the water outlet in accordance with ASME Boiler and Pressure Vessel Code. Pipe the discharge of the safety relief valve to a suitable drain to prevent injury in the event of pressure relief. Provide piping that is the same size as the safety relief valve outlet. Never block the outlet of the safety relief valve.

See the piping illustrations included in this section, Figures 4-2 thru 4-9, for suggested guidelines in piping the water heater.

NOTICE

*Please note that these illustrations are meant to show system piping concept only, the installer is responsible for all equipment and detailing required by local codes.

Cold Water Supply

Cold water supply lines should be connected directly to the HPWH inlet or T fitted into the inlet (return) water piping.

Water Pressure

System water pressure should be maintained above 12 PSI. Local code may require, and the manufacturer recommends, installing a pressure reducing valve (PRV) in the cold water supply to the building to maintain consistent water pressure.

Closed Water Systems

Water supply systems may, because of code requirements or such conditions as high line pressure, among others, have installed devices such as pressure reducing valves, check valves, and back flow preventers. Devices such as these cause the water system to be a closed system.

Water Chemistry

Heating of high hardness and/or high total dissolved solids water is not recommended for the circulating pump based on the water chemistry of the water to be heated. See Table 9-1 in Start-up Section for recommendations.

Water with a hardness of less than 5 grains per gallon will usually have a pH which can be aggressive and corrosive causing non-warrantable damage to the pump, and associated piping. Corrosion due to water chemistry generally shows up first in the hot water system because heated water increases the rate of corrosive chemical reactions.

Condensate Removal

The HPWH unit produces condensate which must be discharged. If there is no drain easily accessible, a condensate lift pump must be installed to discharge the condensate to a remote location. See Condensate Drain Line on page 24 for installation instructions.

Contaminated Water

This HPWH unit must not be used to heat any fluid other than water. Corrosive chemicals must not be introduced into the waterways in this HPWH unit.

WARNING

Corrosive Chemical Hazard

- Connecting the heat pump to any system other than a water system may lead to premature corrosion of the unit's heat exchanger and void the unit warranty.

4 System Piping

Scalding

This water heater can deliver scalding temperature water at any faucet in the system. Be careful whenever using hot water to avoid scalding injury. Certain appliances such as dishwashers and automatic clothes washers may require increased temperature water. By setting the thermostat on this water heater to obtain the increased temperature water required by these appliances, you may create the potential for scald injury. To protect against injury, you should install a mixing valve in the water system. This valve will reduce point of discharge temperature by mixing cold and hot water in branch supply lines. Such valves are available from the local plumbing supplier.

Figure 4-1 Scald Warning Label Located on the Appliance

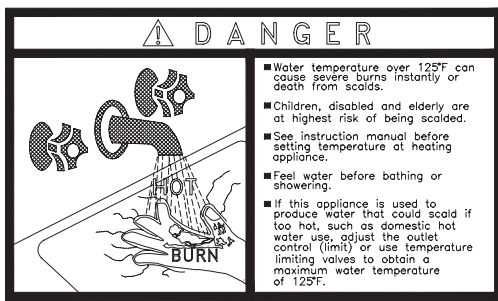

The following chart (Table 4-1) details the relationship of water temperature and time with regard to scald injury and may be used as a guide in determining the safest water temperature for your applications.

Table 4-1 Approximate Time / Temperature Scald Chart

APPROXIMATE TIME / TEMPERATURE RELATIONSHIPS IN SCALDS	
120°F	More than 5 minutes
125°F	1 1/2 to 2 minutes
130°F	About 30 seconds
135°F	About 10 seconds
140°F	Less than 5 seconds
145°F	Less than 3 seconds
150°F	About 1 1/2 seconds
155°F	About 1 second

Piping Components

Water Heater System Piping:

Water heater system piping **MUST** be sized per the pipe requirements listed on the tables included with the Piping Diagrams on pages 28-35. The recommended length of equivalent piping between the tank and water heater should be kept to a maximum of 500 feet. Reducing the pipe size can restrict the flow rate through the water heater, causing high limit shutdowns and poor system performance.

Check Valves:

Field supplied. Check valves are recommended for installation as shown in Figures 4-2 thru 4-9.

Water Heater Isolation Valves:

Field supplied. Full port ball valves are required. Failure to use full port ball valves could result in a restricted flow rate through the water heater.

Anti-scald Mixing Valve:

Field supplied. An anti-scald mixing valve is recommended when storing domestic hot water above 115°F.

Unions:

Field supplied. Recommended for unit serviceability.

Temperature and Pressure Relief Valve:

Field Supplied. The temperature and pressure relief valve is sized to ASME specifications. Storage tanks may require additional valves depending on local codes.

This heat pump water heater should only be connected to a storage tank with a properly rated/sized and certified combination temperature - pressure relief valve. The valve must be certified by a nationally recognized testing laboratory that maintains periodic inspection of production of listed equipment of materials as meeting the requirements for Relief Valves for Hot Water Supply Systems, ANSI Z21.22 • CSA 4.4, and the code requirements of ASME. The pressure rating of the T&P valve should always be rated equal to or below the working pressure rating of the storage tank or water heater, whichever rating is lower. Contact the manufacturer of the storage tank for assistance in sizing of a temperature and pressure relief valve. Follow the storage tank manufacturer's instructions regarding the proper installation of these products.

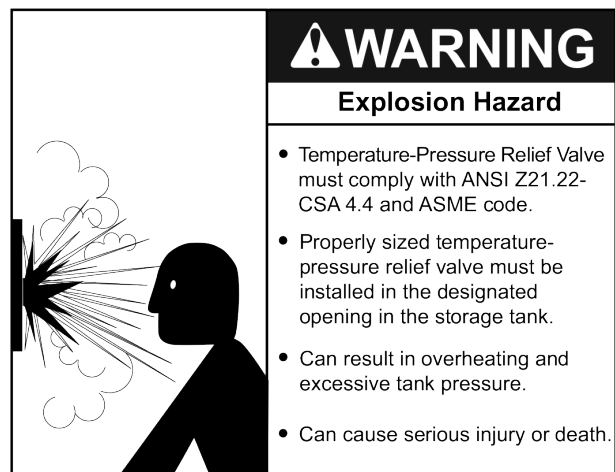

Tank Sensor

The water heater company supplies a tank sensor. The tank sensor must be installed in the tapping provided in the lower/mid section of the storage tank to achieve proper operation. As shipped from the factory, the tank sensor is in the literature package shipped with the unit. Placing the sensor in the tapping provided on the storage tank will improve temperature response and prevent short cycles of operation. While setting the tank setpoint choose the sensor position connected at the system board.

4 System Piping *(continued)*

System Supply Sensor

This sensor is optional and should be located between the tank outlet and mixing valve. If this optional sensor is used, the Boost function may become active. When the tank temperature is rising slower than expected, the outlet temperature will temporarily rise above setpoint to speed up tank charging or in other words “boost” the temperature.

System Return Sensor

This sensor is optional and would be located between the tank and the heat pump inlet.

Strainer:

Field supplied. Required to help eliminate debris from causing damage to the heat exchanger. When installing in a pre-existing system, it is recommended to install a filter in the recirculation line capable of removing debris left in the system.

Building Recirculation Filter:

Field supplied as required. When required, helps to eliminate debris from causing damage to the heat exchanger.

CAUTION Check recirculation pump size to verify it is sized for filter addition and upsize if necessary.

Temperature Sensor Installation

The HPWH unit is shipped from the factory with a Temperature Sensor:

1. Secure the Temperature Sensor inside a Sensor or Thermal Well.
2. Install the sensor well in the storage tank's designated temperature control opening. It is not recommended to install the temperature probe or sensor in the bottom or the top of the tank. It is typical to install in the mid to lower portion of the tank.

Do not install the temperature sensor near the cold water supply connection to the storage tank to prevent short cycling.

Mixing Valves

Water heated to a temperature which will satisfy clothes washing, dish washing, and other sanitizing needs can scald and cause permanent injury upon contact. See Table 4-1, page 26. Some people are more likely to be permanently injured by hot water than others. These include the elderly, children, the infirm, and the physically/mentally disabled. Table 4-1 shows the approximate time-to-burn relationship for normal adult skin. If anyone using hot water provided by the water heater being installed fits into one of these groups or if there is a local code or state law requiring a certain water temperature at the point of use, then special precautions must be taken.

In addition to using the lowest possible temperature setting that satisfies the demand of the application a Mixing Valve should be installed upstream from the building fixtures or at the hot water taps to further reduce system water temperature. Mixing valves are available at plumbing supply stores. Consult a Qualified Installer or Service Agency. Follow the mixing valve manufacturer's instructions for installation of the valves.

Expansion Tank

A properly sized thermal expansion tank must be installed on all closed systems to control the harmful effects of thermal expansion. Contact a local plumbing service agency to have a thermal expansion tank installed on all closed water systems.

Thermal Expansion

As water is heated, it expands (thermal expansion). In a closed system the volume of water will grow when it is heated. As the volume of water grows there will be a corresponding increase in water pressure due to thermal expansion. Thermal expansion can cause premature failure (leakage) of storage tanks, water heaters and HPWH components such as the condenser. Leakage caused by thermal expansion is not covered under the HPWH limited warranty. Thermal expansion can also cause intermittent Temperature- Pressure Relief Valve operation: water discharged due to excessive pressure build up. The Temperature-Pressure Relief Valve is not intended for the constant relief of thermal expansion.

Tank Selection

The HPWH unit is not an instantaneous water heater and must be connected to a storage tank. Storage tank configurations must meet these criteria:

1. The HPWH must not be connected directly to a standard gas or electric heater.
2. If the HPWH is connected to a used storage tank, the tank should be de-scaled and sediment removed before the HPWH is installed.
3. Connection ports used on the storage tank must permit the recommended flow through HPWH. The connection ports used on the storage tank must not be less than the inlet outlet connection sizes on the HPWH unit. See Table 4 on page 13.
4. Water heated by the HPWH should be returned to the tank at a location that is above level of the tank's cold water inlet and/or the heat pump's inlet source. If the inlet and outlet being located at the same level is the only tank option it may be used, but this may reduce performance. The outlet should never go below the cold water inlet.
5. The HPWH unit's inlet and outlet lines to the storage tank should be dedicated. The other line (such as a building re-circulating loop or cold water supply) should be the HPWH unit's inlet water lines.

Solar Tanks

Solar tanks should be used with caution. Some solar tanks with top connections have dip tubes which may significantly reduce the efficiency performance of the HPWH unit.

Maximum/ Minimum Pipe Length

The maximum pipe length is 300 feet. There is no minimum pipe length.

4 System Piping

Figure 4-2 Single Pass - One Heater, One Tank

- NOTES:
1. DRAWING ILLUSTRATES SUGGESTED PIPING CONFIGURATION
LOCAL CODES AND ORDINANCES MAY HAVE ADDITIONAL REQUIREMENTS
 2. DO NOT INCLUDE CHECK VALVES BETWEEN HEAT PUMP OUTLET AND TANK UNLESS REQUIRED BY CODE. INTERNAL HEAT PUMP VALVE PREVENTS BACKFLOW
 3. CHECK VALVE REQUIRED TO PREVENT BACKFLOW TO COLD WATER SUPPLY
 4. SYSTEM REQUIRES ONE TANK SENSOR BUT WILL SUPPORT UP TO SIX TANK SENSORS

Model	Min. Required Pipe Size in NPT (≤ 5 ft/s @14GPM)
060	1 - 1/4
140	1 - 1/4
200	1 - 1/2
280	1 - 1/2
350	2

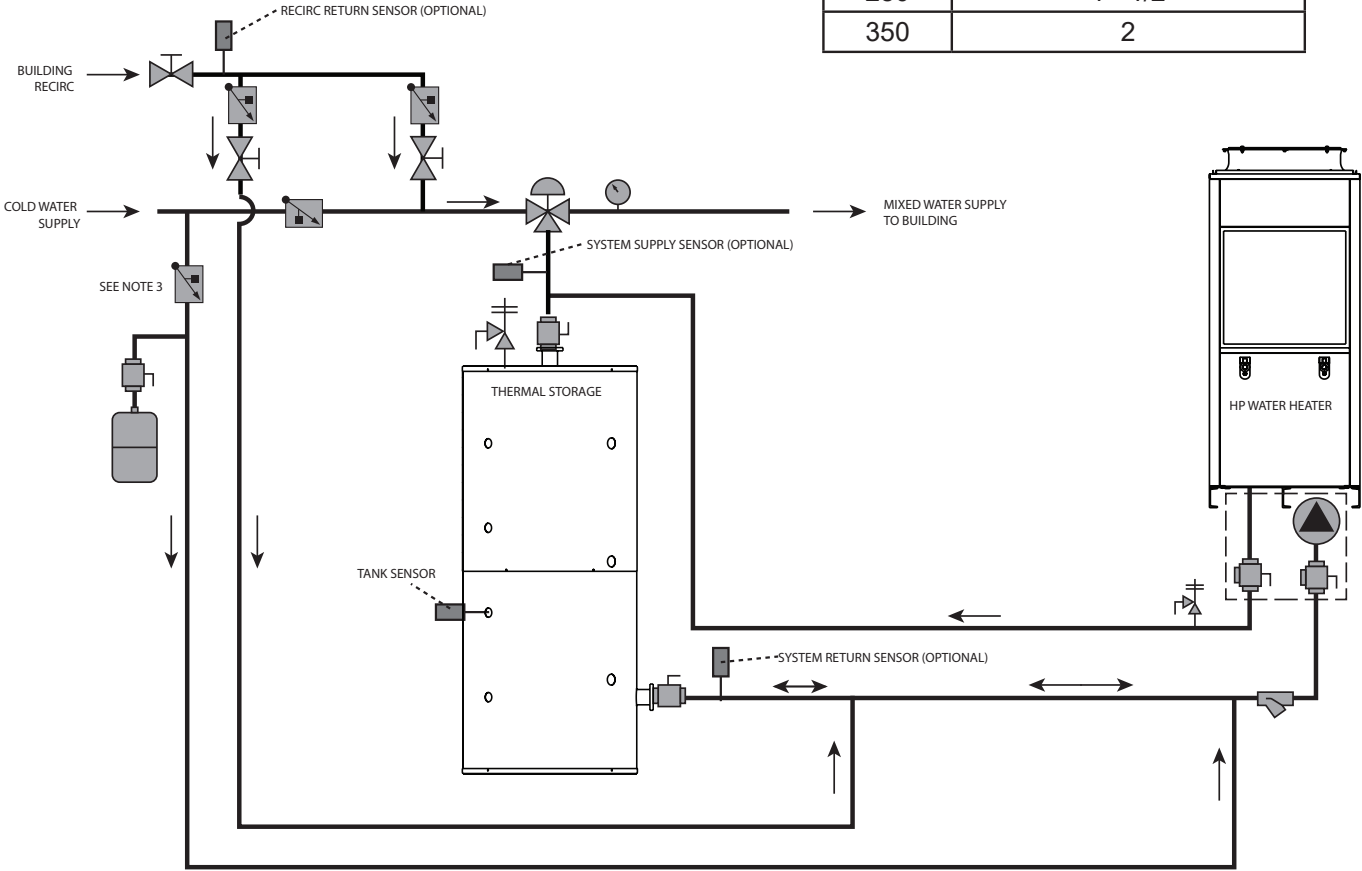

	MIXING VALVE		ISOLATION VALVE		ISOLATING FLUSH VALVE		BALANCING VALVE		PIPING
	CHECK VALVE		CIRCULATING PUMP		WYE STRAINER		FLUSH VALVE		WIRING
	EXPANSION TANK		TEMPERATURE GAUGE		TEMP/PRESS RELIEF VALVE		TEMPERATURE SENSOR		

2000630378_000

Included with heat pump manifold

CAUTION

The piping will not support the weight of the water heater circulator pump. Do not attempt to support the weight of the water heater circulator pump with the piping or its accessories. Refer to the pump manufacturer’s installation instructions. Failure to comply could result in severe personal injury, death, or substantial property damage.

NOTICE

Please note that these illustrations are meant to show system piping concept only, the installer is responsible for all equipment. The installer must follow all manufacturer’s instructions for each system component. The installer is responsible for compliance with local codes.

4 System Piping *(continued)*

Figure 4-3 Single Pass - One Heater, One Tank with Parallel Backup

NOTES:

1. DRAWING ILLUSTRATES SUGGESTED PIPING CONFIGURATION
LOCAL CODES AND ORDINANCES MAY HAVE ADDITIONAL REQUIREMENTS
2. DO NOT INCLUDE CHECK VALVES BETWEEN HEAT PUMP OUTLET AND TANK UNLESS REQUIRED BY CODE. INTERNAL HEAT PUMP VALVE PREVENTS BACKFLOW
3. CHECK VALVE REQUIRED TO PREVENT BACKFLOW TO COLD WATER SUPPLY
4. SYSTEM REQUIRES ONE TANK SENSOR BUT WILL SUPPORT UP TO SIX TANK SENSORS

Model	Min. Required Pipe Size in NPT (≤ 5 ft/s @14GPM)
060	1 - 1/4
140	1 - 1/4
200	1 - 1/2
280	1 - 1/2
350	2

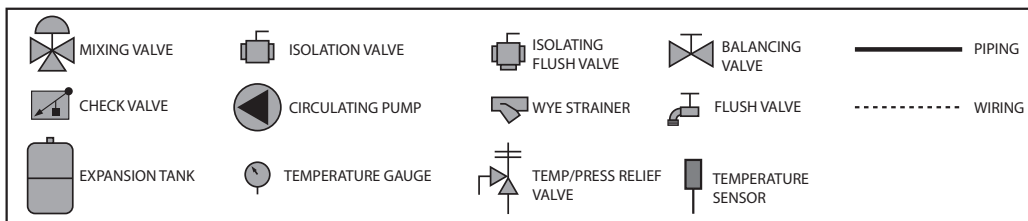
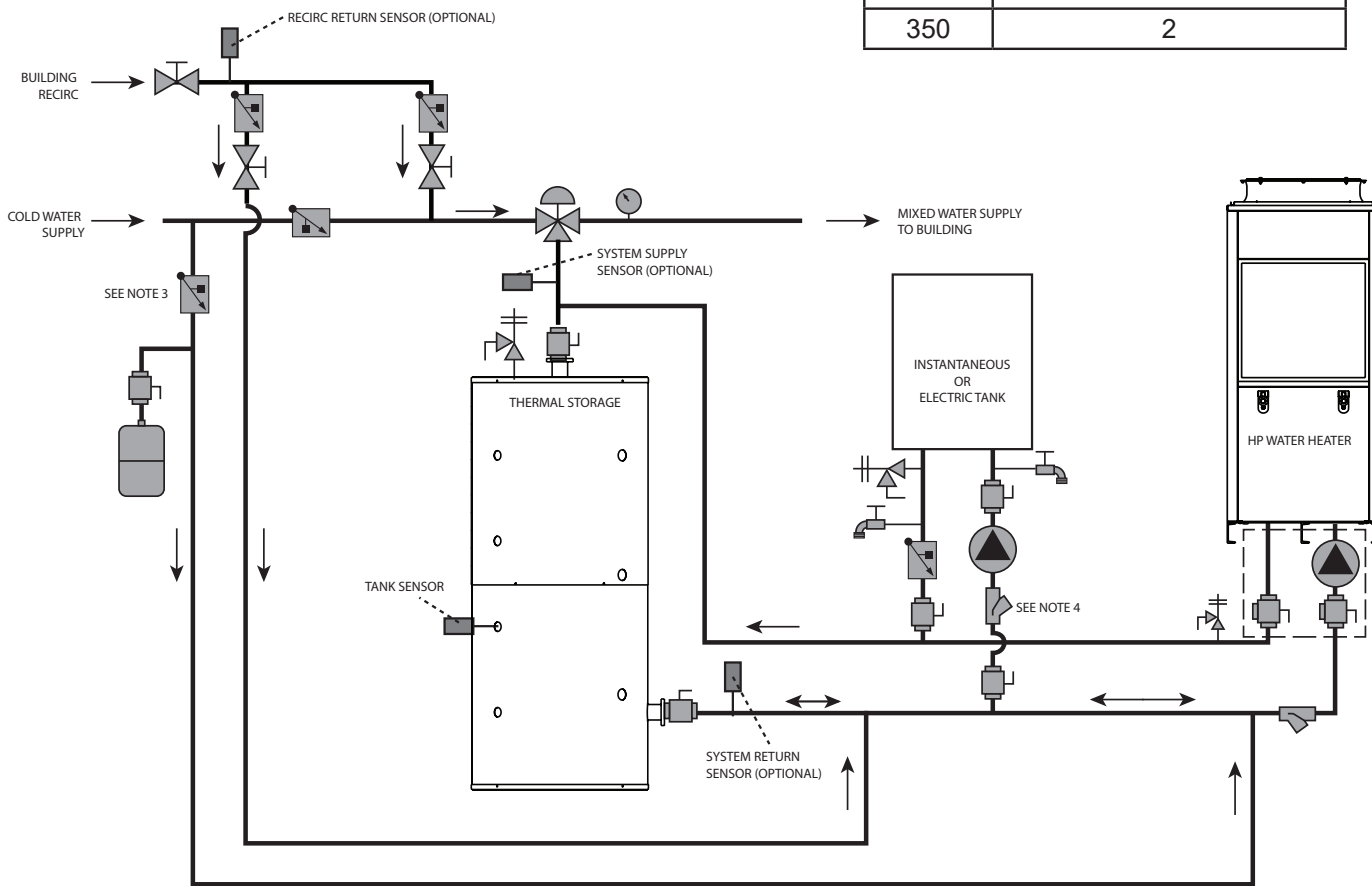

2000630378_000

Included with heat pump manifold

CAUTION

The piping will not support the weight of the water heater circulator pump. Do not attempt to support the weight of the water heater circulator pump with the piping or its accessories. Refer to the pump manufacturer's installation instructions. Failure to comply could result in severe personal injury, death, or substantial property damage.

NOTICE

Please note that these illustrations are meant to show system piping concept only, the installer is responsible for all equipment. The installer must follow all manufacturer's instructions for each system component. The installer is responsible for compliance with local codes.

4 System Piping

Figure 4-4 Single Pass - One Heater, Two Tanks

- NOTES:
1. DRAWING ILLUSTRATES SUGGESTED PIPING CONFIGURATION
LOCAL CODES AND ORDINANCES MAY HAVE ADDITIONAL REQUIREMENTS
 2. DO NOT INCLUDE CHECK VALVES BETWEEN HEAT PUMP OUTLET AND TANK UNLESS REQUIRED BY CODE. INTERNAL HEAT PUMP VALVE PREVENTS BACKFLOW
 3. CHECK VALVE REQUIRED TO PREVENT BACKFLOW TO COLD WATER SUPPLY
 4. SYSTEM REQUIRES ONE TANK SENSOR BUT WILL SUPPORT UP TO SIX TANK SENSORS

Model	Min. Required Pipe Size in NPT (≤ 5 ft/s @14GPM)
060	1 - 1/4
140	1 - 1/4
200	1 - 1/2
280	1 - 1/2
350	2

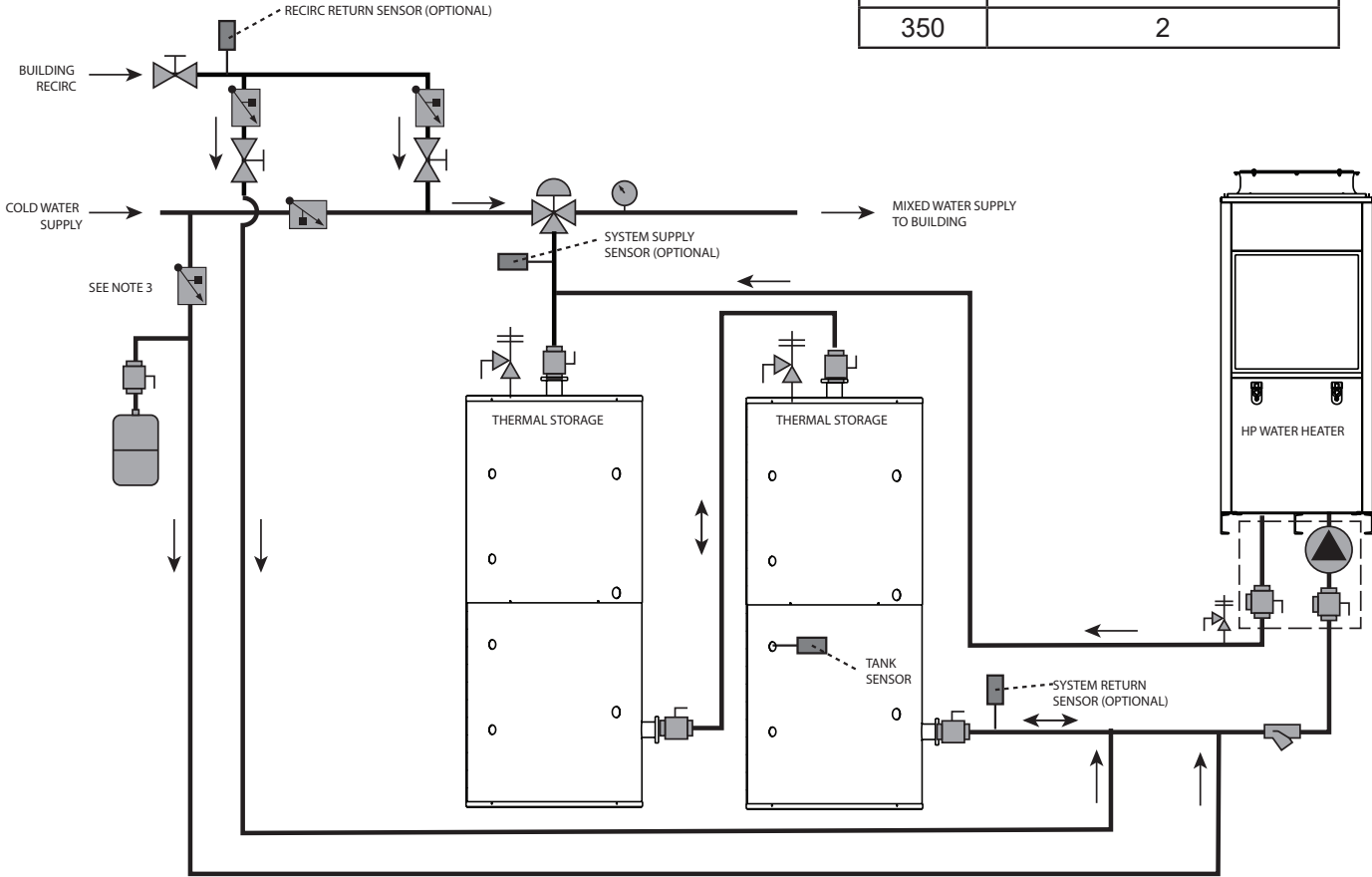

	MIXING VALVE		ISOLATION VALVE		ISOLATING FLUSH VALVE		BALANCING VALVE		PIPING
	CHECK VALVE		CIRCULATING PUMP		WYE STRAINER		FLUSH VALVE		WIRING
	EXPANSION TANK		TEMPERATURE GAUGE		TEMP/PRESS RELIEF VALVE		TEMPERATURE SENSOR		

2000630378_000

Included with heat pump manifold

CAUTION The piping will not support the weight of the water heater circulator pump. Do not attempt to support the weight of the water heater circulator pump with the piping or its accessories. Refer to the pump manufacturer’s installation instructions. Failure to comply could result in severe personal injury, death, or substantial property damage.

NOTICE Please note that these illustrations are meant to show system piping concept only, the installer is responsible for all equipment. The installer must follow all manufacturer’s instructions for each system component. The installer is responsible for compliance with local codes.

4 System Piping *(continued)*

Figure 4-5 Single Pass - Two Heaters, One Tank with Swing Tank and Gas Backup Heat

NOTES:

1. DRAWING ILLUSTRATES SUGGESTED PIPING CONFIGURATION
LOCAL CODES AND ORDINANCES MAY HAVE ADDITIONAL REQUIREMENTS
2. DO NOT INCLUDE CHECK VALVES BETWEEN HEAT PUMP OUTLET AND TANK UNLESS REQUIRED BY CODE. INTERNAL HEAT PUMP VALVE PREVENTS BACKFLOW
3. CHECK VALVE REQUIRED TO PREVENT BACKFLOW TO COLD WATER SUPPLY
4. SYSTEM REQUIRES ONE TANK SENSOR BUT WILL SUPPORT UP TO SIX TANK SENSORS

Model	Min. Required Pipe Size in NPT (≤ 5 ft/s @14GPM)
060	1 - 1/4
140	1 - 1/4
200	1 - 1/2
280	1 - 1/2
350	2

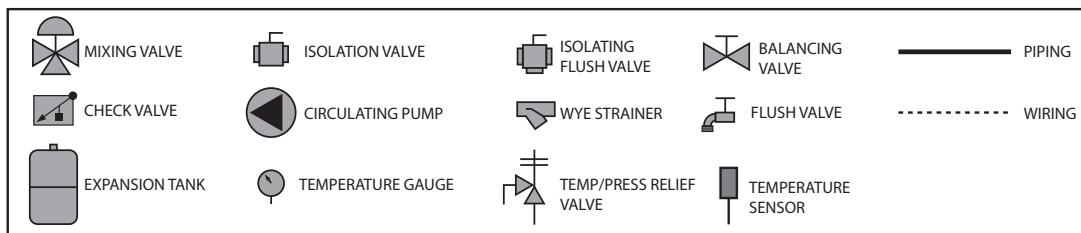
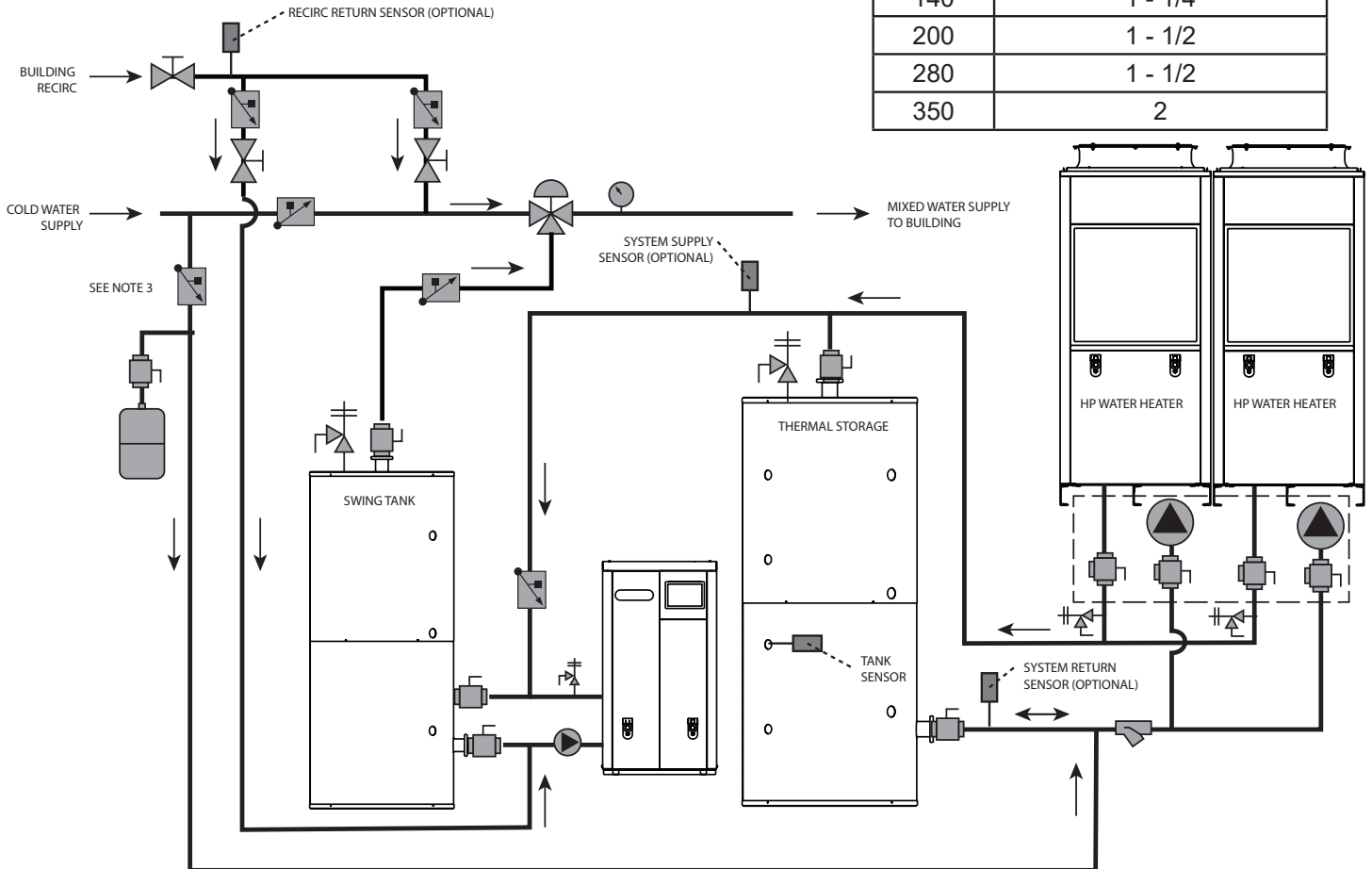

Included with heat pump manifold

2000630378_000

CAUTION The piping will not support the weight of the water heater circulator pump. Do not attempt to support the weight of the water heater circulator pump with the piping or its accessories. Refer to the pump manufacturer's installation instructions. Failure to comply could result in severe personal injury, death, or substantial property damage.

NOTICE Please note that these illustrations are meant to show system piping concept only, the installer is responsible for all equipment. The installer must follow all manufacturer's instructions for each system component. The installer is responsible for compliance with local codes.

4 System Piping

Figure 4-6 Single Pass - Two Heaters, One Tank with Swing Tank

- NOTES:
1. DRAWING ILLUSTRATES SUGGESTED PIPING CONFIGURATION LOCAL CODES AND ORDINANCES MAY HAVE ADDITIONAL REQUIREMENTS
 2. DO NOT INCLUDE CHECK VALVES BETWEEN HEAT PUMP OUTLET AND TANK UNLESS REQUIRED BY CODE. INTERNAL HEAT PUMP VALVE PREVENTS BACKFLOW
 3. CHECK VALVE REQUIRED TO PREVENT BACKFLOW TO COLD WATER SUPPLY
 4. SYSTEM REQUIRES ONE TANK SENSOR BUT WILL SUPPORT UP TO SIX TANK SENSORS

Model	Min. Required Pipe Size in NPT (≤ 5 ft/s @14GPM)
060	1 - 1/4
140	1 - 1/4
200	1 - 1/2
280	1 - 1/2
350	2

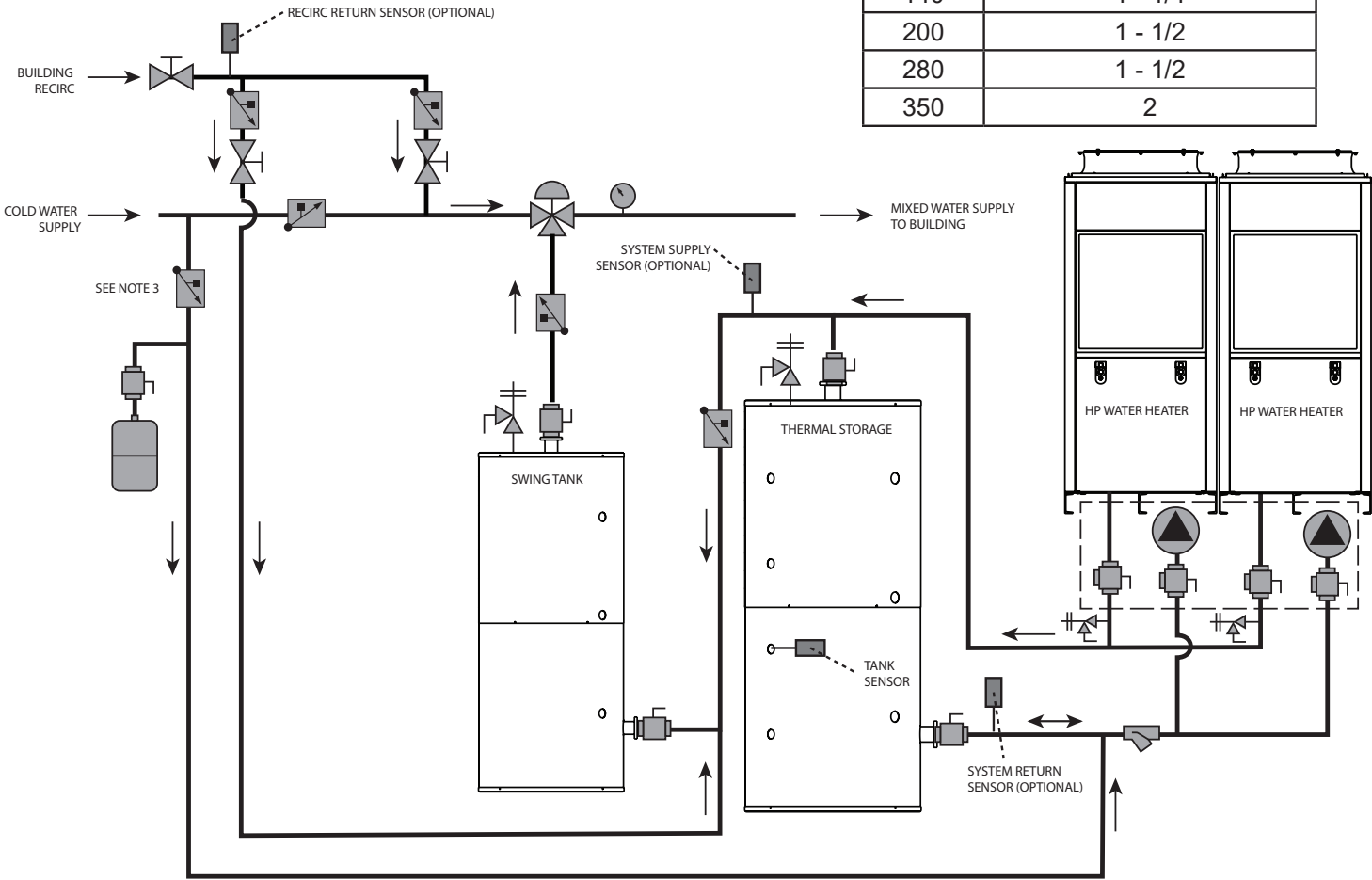

MIXING VALVE	ISOLATION VALVE	ISOLATING FLUSH VALVE	BALANCING VALVE	PIPING
CHECK VALVE	CIRCULATING PUMP	WYE STRAINER	FLUSH VALVE	WIRING
EXPANSION TANK	TEMPERATURE GAUGE	TEMP/PRESS RELIEF VALVE	TEMPERATURE SENSOR	

Included with heat pump manifold

2000630378_000

CAUTION The piping will not support the weight of the water heater circulator pump. Do not attempt to support the weight of the water heater circulator pump with the piping or its accessories. Refer to the pump manufacturer’s installation instructions. Failure to comply could result in severe personal injury, death, or substantial property damage.

NOTICE Please note that these illustrations are meant to show system piping concept only, the installer is responsible for all equipment. The installer must follow all manufacturer’s instructions for each system component. The installer is responsible for compliance with local codes.

4 System Piping *(continued)*

Figure 4-7 Single Pass - Two Heaters, Two Tanks

NOTES:

1. DRAWING ILLUSTRATES SUGGESTED PIPING CONFIGURATION
LOCAL CODES AND ORDINANCES MAY HAVE ADDITIONAL REQUIREMENTS
2. DO NOT INCLUDE CHECK VALVES BETWEEN HEAT PUMP OUTLET AND TANK UNLESS REQUIRED BY CODE. INTERNAL HEAT PUMP VALVE PREVENTS BACKFLOW
3. CHECK VALVE REQUIRED TO PREVENT BACKFLOW TO COLD WATER SUPPLY
4. SYSTEM REQUIRES ONE TANK SENSOR BUT WILL SUPPORT UP TO SIX TANK SENSORS

Model	Min. Required Pipe Size in NPT (≤ 5 ft/s @14GPM)
060	1 - 1/4
140	1 - 1/4
200	1 - 1/2
280	1 - 1/2
350	2

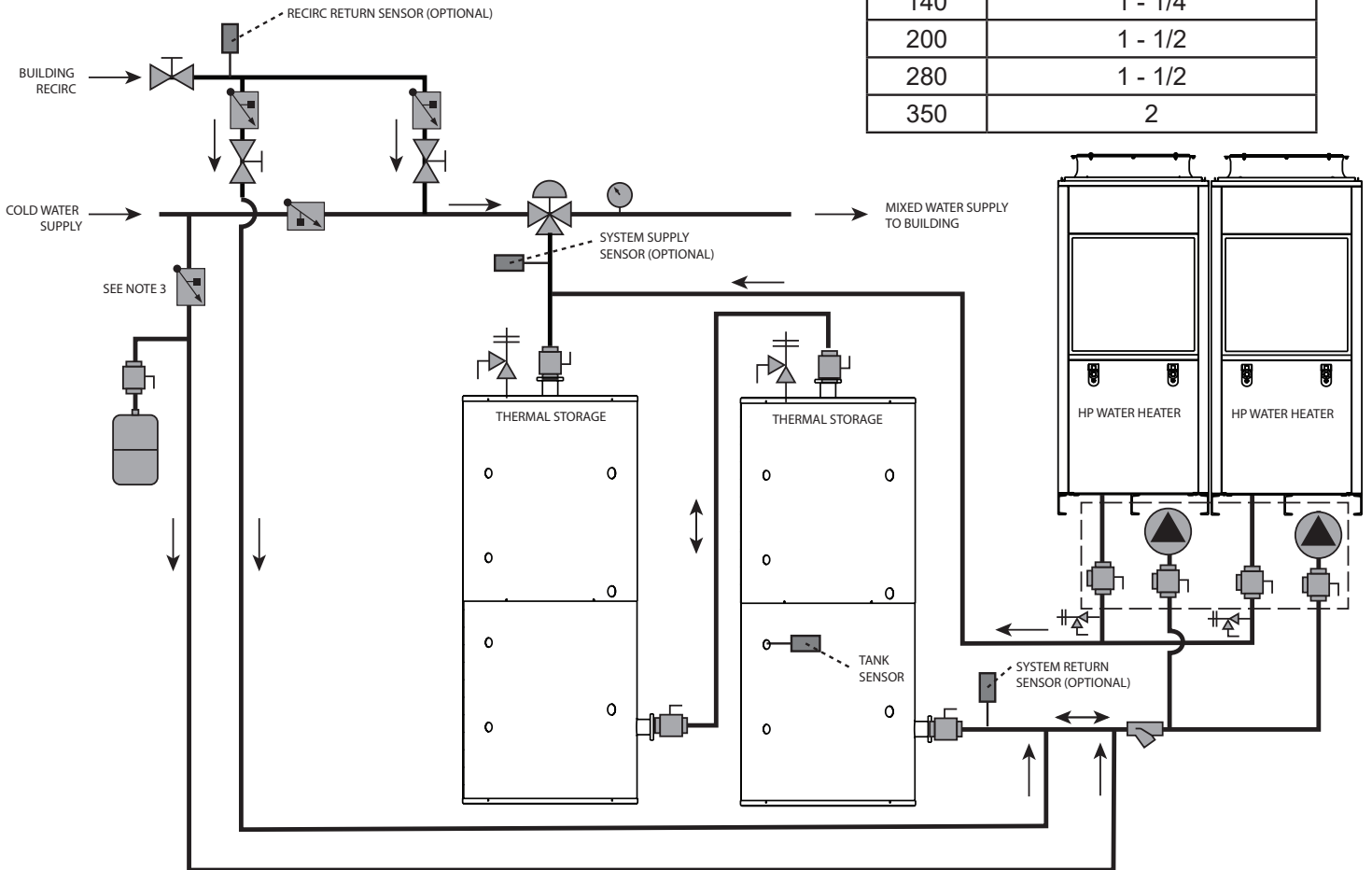

	MIXING VALVE		ISOLATION VALVE		ISOLATING FLUSH VALVE		BALANCING VALVE		PIPING
	CHECK VALVE		CIRCULATING PUMP		WYE STRAINER		FLUSH VALVE		WIRING
	EXPANSION TANK		TEMPERATURE GAUGE		TEMP/PRESS RELIEF VALVE		TEMPERATURE SENSOR		

2000630378_000

Included with heat pump manifold

CAUTION

The piping will not support the weight of the water heater circulator pump. Do not attempt to support the weight of the water heater circulator pump with the piping or its accessories. Refer to the pump manufacturer's installation instructions. Failure to comply could result in severe personal injury, death, or substantial property damage.

NOTICE

Please note that these illustrations are meant to show system piping concept only, the installer is responsible for all equipment. The installer must follow all manufacturer's instructions for each system component. The installer is responsible for compliance with local codes.

4 System Piping

Figure 4-8 Single Pass - Two Heaters, Two Tanks with Electric Backup

NOTES:

1. DRAWING ILLUSTRATES SUGGESTED PIPING CONFIGURATION
- LOCAL CODES AND ORDINANCES MAY HAVE ADDITIONAL REQUIREMENTS
2. DO NOT INCLUDE CHECK VALVES BETWEEN HEAT PUMP OUTLET AND TANK UNLESS REQUIRED BY CODE. INTERNAL HEAT PUMP VALVE PREVENTS BACKFLOW
3. CHECK VALVE REQUIRED TO PREVENT BACKFLOW TO COLD WATER SUPPLY
4. SYSTEM REQUIRES ONE TANK SENSOR BUT WILL SUPPORT UP TO SIX TANK SENSORS

Model	Min. Required Pipe Size in NPT (≤ 5 ft/s @14GPM)
060	1 - 1/4
140	1 - 1/4
200	1 - 1/2
280	1 - 1/2
350	2

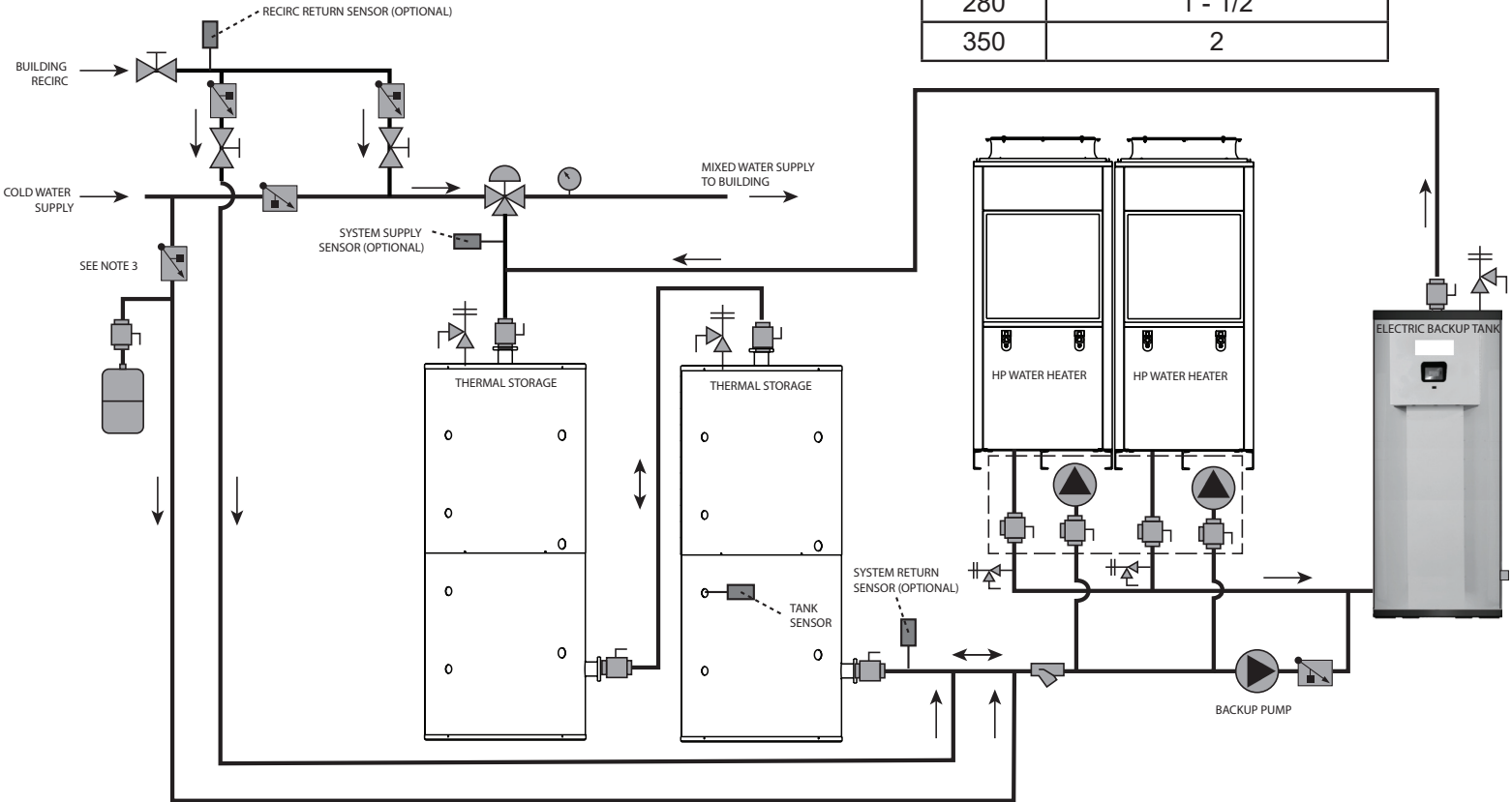

	MIXING VALVE		ISOLATION VALVE		ISOLATING FLUSH VALVE		BALANCING VALVE		PIPING
	CHECK VALVE		CIRCULATING PUMP		WYE STRAINER		FLUSH VALVE		WIRING
	EXPANSION TANK		TEMPERATURE GAUGE		TEMP/PRESS RELIEF VALVE		TEMPERATURE SENSOR		

2000630378_000

Included with heat pump manifold

CAUTION The piping will not support the weight of the water heater circulator pump. Do not attempt to support the weight of the water heater circulator pump with the piping or its accessories. Refer to the pump manufacturer’s installation instructions. Failure to comply could result in severe personal injury, death, or substantial property damage.

NOTICE Please note that these illustrations are meant to show system piping concept only, the installer is responsible for all equipment. The installer must follow all manufacturer’s instructions for each system component. The installer is responsible for compliance with local codes.

4 System Piping *(continued)*

Figure 4-9 Multi Pass - One Heater, One Tank

NOTES:

1. DRAWING ILLUSTRATES SUGGESTED PIPING CONFIGURATION
2. LOCAL CODES AND ORDINANCES MAY HAVE ADDITIONAL REQUIREMENTS
3. DO NOT INCLUDE CHECK VALVES BETWEEN HEAT PUMP OUTLET AND TANK UNLESS REQUIRED BY CODE. INTERNAL HEAT PUMP VALVE PREVENTS BACKFLOW
4. CHECK VALVE REQUIRED TO PREVENT BACKFLOW TO COLD WATER SUPPLY
5. SYSTEM REQUIRES ONE TANK SENSOR BUT WILL SUPPORT UP TO SIX TANK SENSORS

Model	Min. Required Pipe Size in NPT (≤ 5 ft/s @14GPM)
060	1 - 1/4
140	1 - 1/4
200	1 - 1/2
280	1 - 1/2
350	2

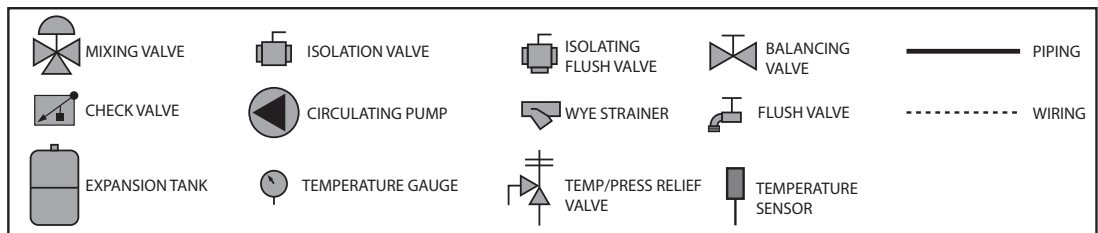
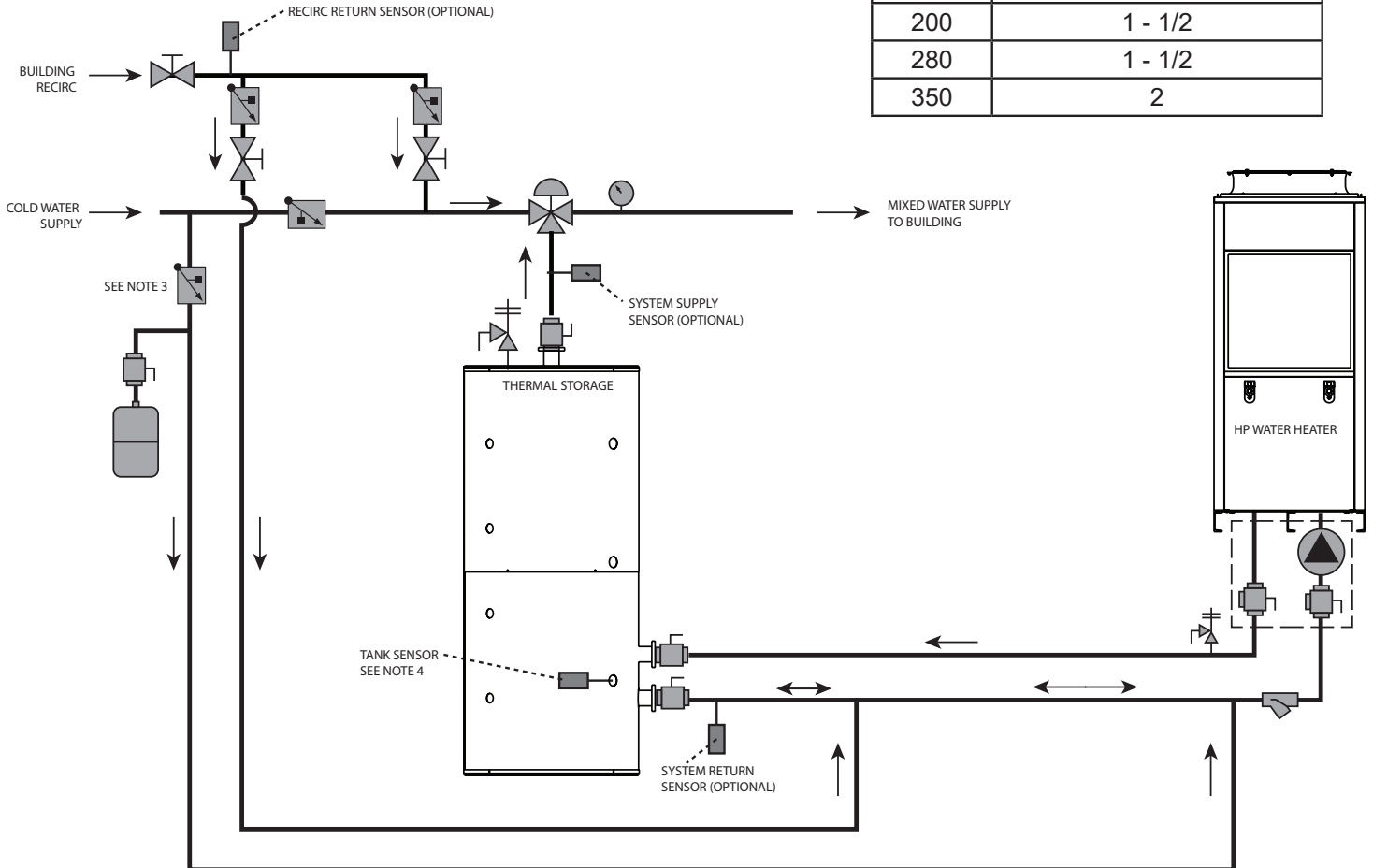

2000630378_000

Included with heat pump manifold

CAUTION

The piping will not support the weight of the water heater circulator pump. Do not attempt to support the weight of the water heater circulator pump with the piping or its accessories. Refer to the pump manufacturer's installation instructions. Failure to comply could result in severe personal injury, death, or substantial property damage.

NOTICE

Please note that these illustrations are meant to show system piping concept only, the installer is responsible for all equipment. The installer must follow all manufacturer's instructions for each system component. The installer is responsible for compliance with local codes.

5 Air Flow and Ducting

General Guidelines

Review Locating The Water Heater on page 16, and this section prior to connecting ductwork to the HPWH.

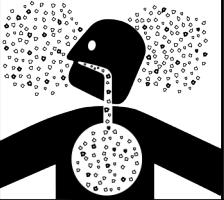
! WARNING	
Breathing Hazard - Carbon Monoxide Gas	
	<ul style="list-style-type: none"> Do not duct air from a garage or other space where potentially harmful fumes from solvents, chemicals or exhaust from automobiles are present into any other space in the building structure. Gas and carbon monoxide detectors are available.
<p>Breathing carbon monoxide can cause brain damage or death. Always read and understand instruction manual.</p>	

The supply (outlet) air from a HPWH installed in a garage or a unit drawing return (inlet) air from a garage or any area where solvents or other chemicals that emit potentially harmful fumes are stored or automobiles are located must never be ducted to any other space inside the building structure. This would include all occupied and unoccupied spaces such as attics or basements. Potentially harmful fumes and vapors could be introduced into occupied spaces. See Unit Placement on page 16.

Duct Sizing

Supply and return air ducting must be sized properly to ensure requirements for the total equivalent supply and return duct lengths allowed. Exceeding those maximum lengths will adversely affect the operation of the heat pump. Consult the factory for sizing.

Duct Insulation

The cooled air from the HPWH may be below room dew point. Insulate the supply duct to prevent dripping from moisture condensing on the duct. It is not necessary to insulate return ducts unless the air in the return duct is lower than the room air. Also consider insulating all ductwork to reduce blower noise from the unit.

Make Duct Connections

Install all ductwork to and from unit in accordance with all applicable codes. Duct construction must allow unit to operate within the limits of the unit external static pressure as in the HPWH unit's performance and specification sheets. See Table 1-1 on page 18 also. Use flexible connections to minimize duct-to-duct alignment problems and noise transmission. Install ductwork, accessory grilles, and plenums so that they do not restrict access to the optional filter (consult factory for merv rating), and so they prevent dirt, dust, and debris from settling in the unit.

Ducting Multiple Units

The HPWHs can be ducted together into a common header, but only if the static pressure can be maintained with the other pieces of equipment. If this is done, the Engineer of Record needs to take extra precautions around this design and assumes responsibility for overdrawing amperage on the motors, blown fuses, and all other air side issues that may arise.

Building Air Pressure

When installing ducting to or from an alternate location (other than the installed space) both the supply (outlet) and return (inlet) air may need to be ducted to prevent positive or negative building air pressure conditions within the installed space.

Negative Pressure

Ducting supply air only to an alternate location, such as the outdoors, may cause excessive negative air pressure inside the building envelope. Excessive negative pressure inside the building structure may result in cold or hot air from outdoors being drawn inside the building and place additional load on space heating and cooling equipment. Negative air pressure in buildings can also cause reverse flow in chimneys and gas vents.

Positive Pressure

Ducting return air only from an alternate location, such as the outdoors, may cause excessive positive air pressure inside the building envelope.

Excessive positive pressure inside the building structure may place additional load on space heating and cooling equipment by interfering with the delivery of conditioned air.

When to Install Ducting

HPWH units are often installed in unoccupied spaces or equipment rooms where there is an ample source of ambient heat and no need to redirect the supply air to another location. Ductwork is not necessary in these circumstances. See Heat Source on page 16.

Typical applications when ducting is installed.

- Duct supply (outlet) air to alternate location for spot cooling or discard supply air not wanted in the installed space.
- Duct return (inlet) air from an alternate location (outdoors, warm equipment room) to optimize efficiency.

5 Air Flow and Ducting *(continued)*

Supply Air Ducting

Observe and follow these guidelines and instructions when installing supply (outlet) air duct:

- When duct work is not field connected to the supply air outlet on the HPWH unit a field supplied safety guard must be installed over the supply air connection. Failure to comply could result in severe injury.
- All duct work and plenums shall be field supplied or fabricated.
- Cooling output (supply air) from the HPWH is supplemental only and must not be factored into sizing calculations for space cooling equipment. Cooling output is only produced when the HPWH is operating to satisfy a water heating demand. Once the storage tank temperature is satisfied, the HPWH will stop until the next water heating demand is initiated regardless of space cooling needs.
- All duct work and plenums shall be field supplied or depending on the temperature of the air entering the HPWH unit the supply air may not be suitable for supplemental space cooling purposes. **A field supplied/fabricated flex connector should be added between the unit and duct for service work when required.**
- The air temperature drops approximately 12°F to 20°F (7°C to 11°C) as it flows through the HPWH unit. If the return air to the HPWH unit is derived from a location that is above 80°F (27°C) the supply air from the HPWH unit will not be suitable for off setting the building cooling load. This will often be the case when the return air is ducted from a warm equipment room or from the outdoor atmosphere. In these circumstances do not duct supply air to another location for spot cooling.
- Ducting supply air only to an alternate location, such as the outdoors, may cause excessive negative air pressure inside the building envelope.
- Provision must be made to prevent a negative pressure in the installed space or building envelope. Return air must be supplied to the HPWH from the alternate location through ducting or louvers that communicate with the alternate location where the supply ducting terminates. See the Return Air Ducting section that follows.
- **When installing the duct, install a flex connector between the duct and unit for serviceability.**

Figure 5-1 Supply air ducting

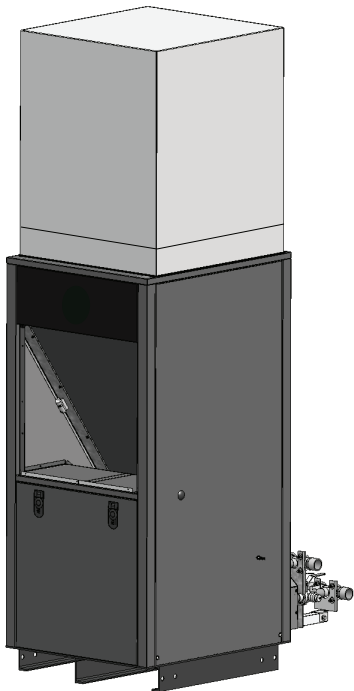

5 Air Flow and Ducting

Return Air Ducting

Observe and follow these guidelines and instructions when installing return (inlet) air duct:

- All ductwork and plenums shall be field supplied or fabricated.
- When installing return air duct to the HPWH unit a field supplied/fabricated flex connector should be added between the unit and duct for service work when required.
- If a field supplied filter is required choose a location that has easy access for servicing the filter as needed.
- Ducting return air only from an alternate location, such as the outdoors, may cause excessive positive air pressure inside the building envelope.
- Provision must be made to prevent a positive pressure in the installed space or building envelope. Supply air must be supplied to the HPWH from the alternate location through ducting that communicates with the alternate location from where the return air is derived. See the preceding Supply Air Ducting section.
- When installing the duct, install a flex connector between the duct and unit for serviceability.

Figure 5-2 Return air ducting

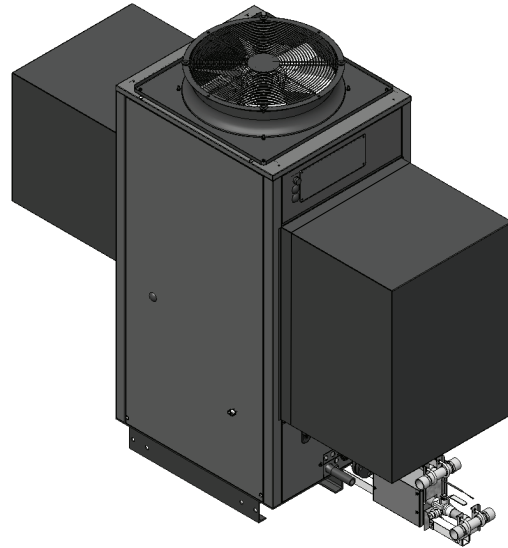

⚠ DANGER

Sharp Spinning Blades!

The blower operates at a high RPM that can cause injury. To prevent inadvertent access to the blower opening, supply ducting or other suitable means to prevent access must be provided.

6 Outdoor Installations

Outdoor Air Inlet and Outlet

Keep HPWH air intake areas free of obstructions. Keep area clean and free of corrosive materials. Maintain a minimum of 36 inches (915 mm) clearance to the air inlet. To avoid a blocked air inlet or outlet condition, keep the air inlet, air outlet, and drain clear of leaves, debris, etc.

Do not install outdoor models directly on the ground. You must install the outdoor unit on a concrete, brick, block, or other noncombustible pad.

Do not locate unit so that high winds can deflect off of adjacent walls, buildings, or shrubbery causing recirculation.

Locate unit at least 10 feet (3.05 m) away from any forced air inlet. See Figure 6-1.

Locate unit at least 3 feet (0.91 m) outside any overhang.

Clearances around outdoor installations can change with time. Do not allow the growth of trees, shrubs, or other plants to obstruct the proper operation of the outdoor vent system.

Do not install in locations where rain from building runoff drains will spill onto the unit.

Figure 6-1 Unit distance from forced air inlet

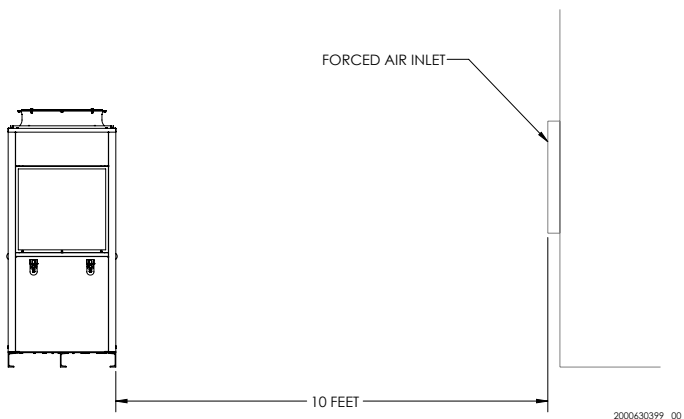

7 Field Wiring

WARNING ELECTRICAL SHOCK HAZARD – For your safety, turn off electrical power supply before making any electrical connections to avoid possible electric shock hazard. Failure to do so can cause severe personal injury or death.

NOTICE

Wiring must be N.E.C. Class 1.

If original wiring as supplied with the water heater must be replaced, use only type 105°C wire or equivalent.

The water heater must be electrically grounded as required by National Electrical Code ANSI/NFPA 70 – latest edition.

CAUTION

Label all wires prior to disconnection when servicing controls. Wiring errors can cause improper and dangerous operation.

Installation must comply with:

1. National Electrical Code and any other national, state, provincial, or local codes, or regulations.
2. In Canada, CSA C22.1 Canadian Electrical Code Part 1, and any local codes.

Line voltage connections

1. Connect 480 VAC 3PH power wiring to the line voltage fuse block in the junction box, as shown in FIG. 7-1.
2. Provide and install a fused disconnect (or service switch sized per the HPWH amp draw (shown on the HPWH rating plate) as required by the code.
3. For alternate voltages, consult factory.
4. Route pump wires through the knockouts in the lower back panel of the unit, as shown in Figure 7-2.
5. The display panel will require 120 VAC to power the system board. Route all wires (power wire 18 gauge) through the conduit using knockouts in the bottom side of the display panel, as shown in Figure 7-3.

CAUTION

If an optional field-installed E-Stop is required, it **MUST BE** wired in series with all nongrounded current-carrying conductors per local and national codes to ensure proper power disconnect per each water heater. There is no other electrical connection to the water heater that serves as an emergency disconnect.

Figure 7-1 Line Voltage Field Wiring Main Power Connections

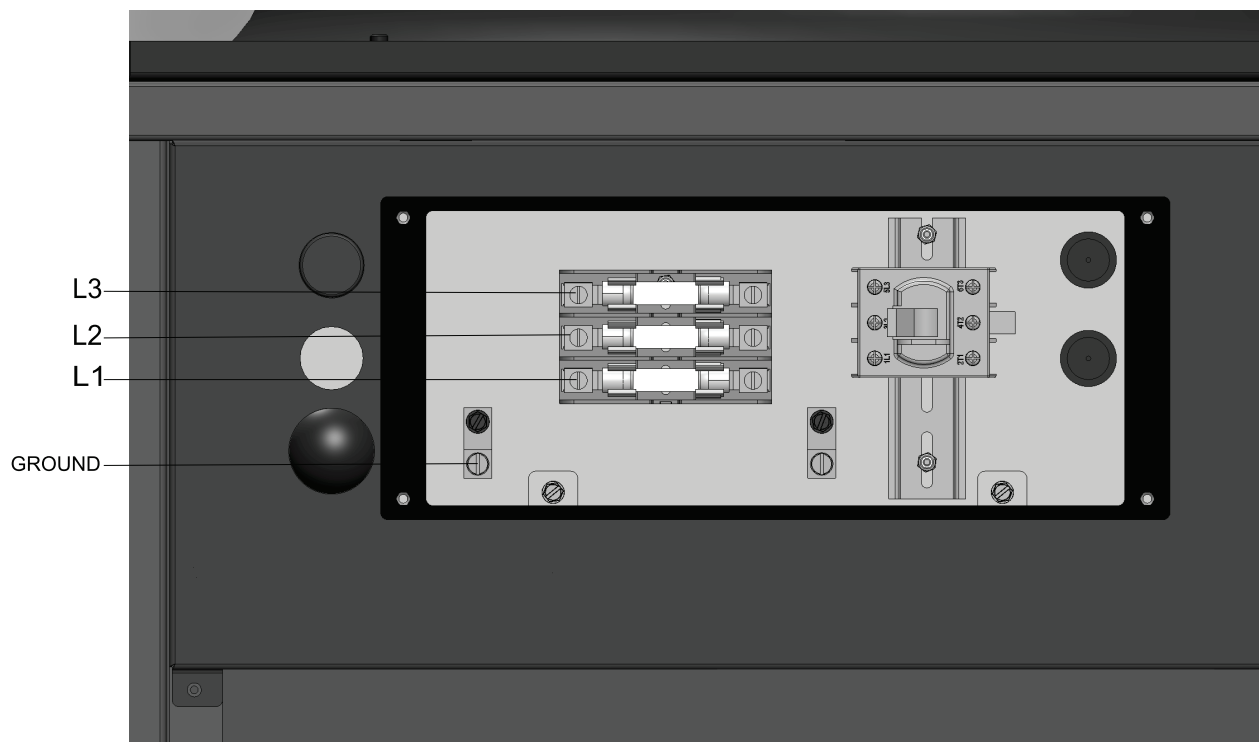

7 Field Wiring *(continued)*

Figure 7-2 Pump Wiring

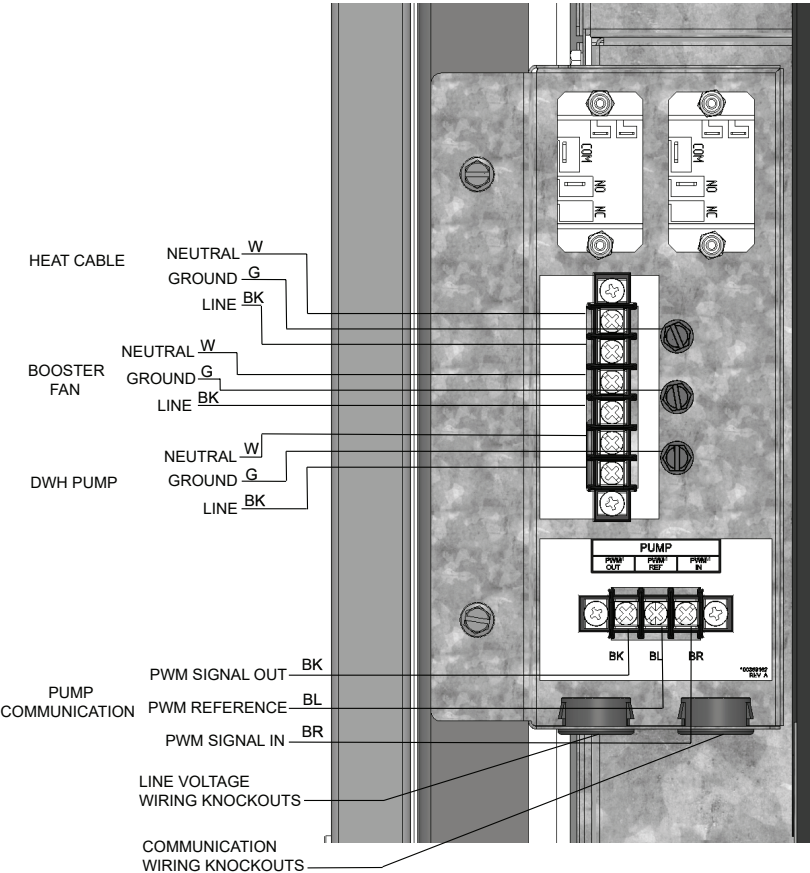
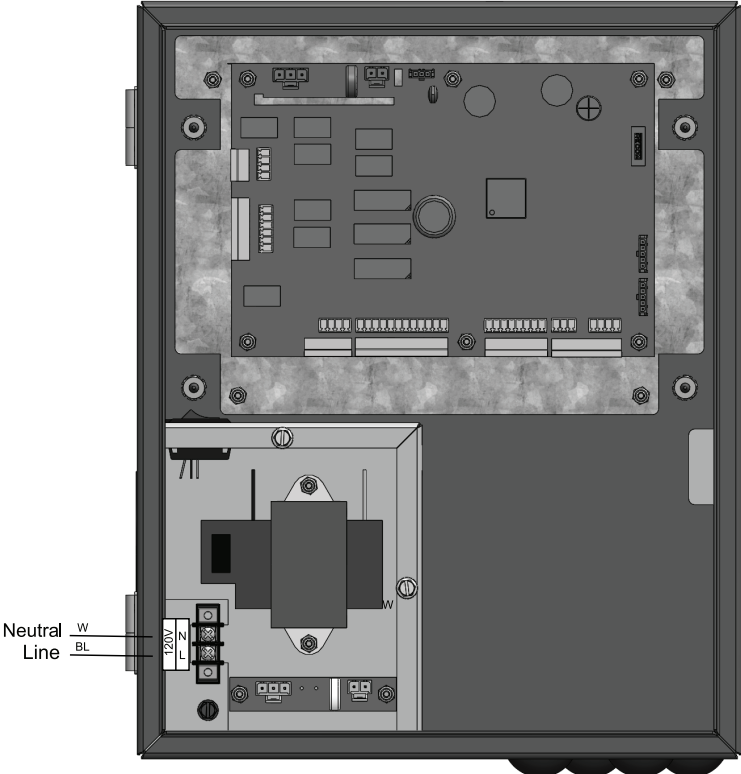

Figure 7-3 Wiring Display Box Power



7 Field Wiring

Low Voltage Connections

1. Route all low voltage wires through the knockouts in the bottom of the display panel, and reference connections in Figure 7-5.
2. Connect low voltage wiring to the system control board as shown in Figure 7-1 of this manual and the HPWH wiring diagram.

High Voltage Connections

Booster Blower

Connect an external 120VAC relay to power a booster blower at the connections shown in Figure 7-2 if desired. The maximum allowed amp draw is 0.50A. These terminals will be powered with 120VAC whenever the heat pump fan is operating.

Heat Cable

Connect an external 120VAC auxiliary heat cable at the connections shown in Figure 7-2 if desired. The maximum allowed amp draw is 3.00A. These contacts are always powered when the heat pump is powered.

Tank Thermostat

1. A tank sensor is required for use. Additionally, a thermostat or another type of switch may be used in conjunction with a sensor to enable or disable the water heater. Remove the jumper and connect the thermostat at the J2 Enable contacts, as shown in Figure 7-5.

Tank Sensor

1. There are board connections for one to six sensors, but only one is required. By installing the tank sensor, the SMART TOUCH control can perform the tank thermostat function. The SMART TOUCH control automatically detects the presence of this sensor and generates a DHW call for heat when the tank temperature drops below the programmed differential and finishes the call for heat when the tank temperature reaches above the programmed offset.
2. The tank sensor 100208545 is the only sensor suitable for use with the SMART TOUCH control. Connect the sensor leads to the tank sensor terminals on the system control board (Figure 7-5).

Louver Proving Switch

When the operation of the louvers needs to be verified before the water heater starts, remove the jumper wire from these terminals and connect them to the normally open contacts on its proving switch (Figure 7-5).

ModBus / BACnet

When the optional ModBus / BACnet interface module is installed, the RS-485 ModBus / BACnet cable is connected to these terminals. Use shielded, 2-wire twisted pair cable. If desired, the shield can be connected to ground by installing a jumper wire between terminals 1 and 3 on connector X5 on the optional ModBus / BACnet interface module.

Water Heater Building Management System (BMS)

1. An external control may be connected to control by the set point of the water heater. If the external control uses a set of contacts to enable the water heater, connect the contacts to the Tank Thermostat terminals. Otherwise, the SMART TOUCH control will be enabled by the 0-10V signal.
2. Make sure the (-) terminal is connected to the (-) or common output terminal of the external control, and the (+) terminal is connected to the (+) or 0 - 10 VDC terminal of the external control. Make sure the (-) voltage is not below ground.

Runtime contacts

The SMART TOUCH control closes a set of dry contacts whenever the heat pump is running. This is typically used by Building Management Systems to verify that the water heater is responding to a call for heat.

Alarm contacts

The SMART TOUCH control closes another set of contacts whenever the water heater is locked out or the power is turned off. This can be used to turn on an alarm, or signal a Building Management System that the water heater is down.

Replaceable Fuses

- Time Delay SC Class G, 600VAC, 40 Amp
- Time Delay SC Class G, 600VAC, 1 Amp
- Inline Fuse: Eaton AHC-2-R, 2A 600VAC, 10KA

Wiring of the Cascade

Connect the tank sensor to the system control board. For the Cascade system to work properly, the tank sensor must be installed. The tank sensor should be wired to the system control board at the terminals marked for the tank sensor. The control will use the water temperature at the tank sensor to control the operation of the Cascade.

7 Field Wiring *(continued)*

Communication between water heaters is accomplished by using the shielded, 2-wire twisted pair harness that is provided. This harness will connect the system control board (SCB) to the first heat pump control board (HPC), and then connect every subsequent heat pump control board (HPC) in the cascade. Use the provided Belden 9322 wire suitable for wet environments or similar. Begin by connecting the twisted pair cable to J11 on the SCB. There are three RS485 communication ports available here. See below table for pin description. From J11 on the SCB, route the other end of the cable into the side of the 1st heat pump. Route the cable through the side of control panel to connection J27 on the HPC. See below table for pin description. If there are subsequent heat pumps in the cascade, route another cable from J7 of the 1st heat pump, out the other side of the unit, into the side of the unit and connect to J27 of the 2nd heat pump. Repeat for the total number of heat pumps in the cascade. The connections between heaters can be made in any order, regardless of the addresses of the water heaters. Try to keep each cable as short as possible.

Table 7-1 Cascade Connections

SCB Connection J11	
PIN	DESCRIPTION
1	DGND
2	RS485-B
3	RS485-A
4	DGND
5	RS485-B
6	RS485-A
7	DGND
8	RS485-B
9	RS485-A
HPC Connection J27	
PIN	DESCRIPTION
1	DGND
2	-
3	RS485-A
4	RS485-B
HPC Connection J7	
PIN	DESCRIPTION
1	DGND
2	-
3	RS485-A
4	RS485-B

Figure 7-4 Cascade Connections

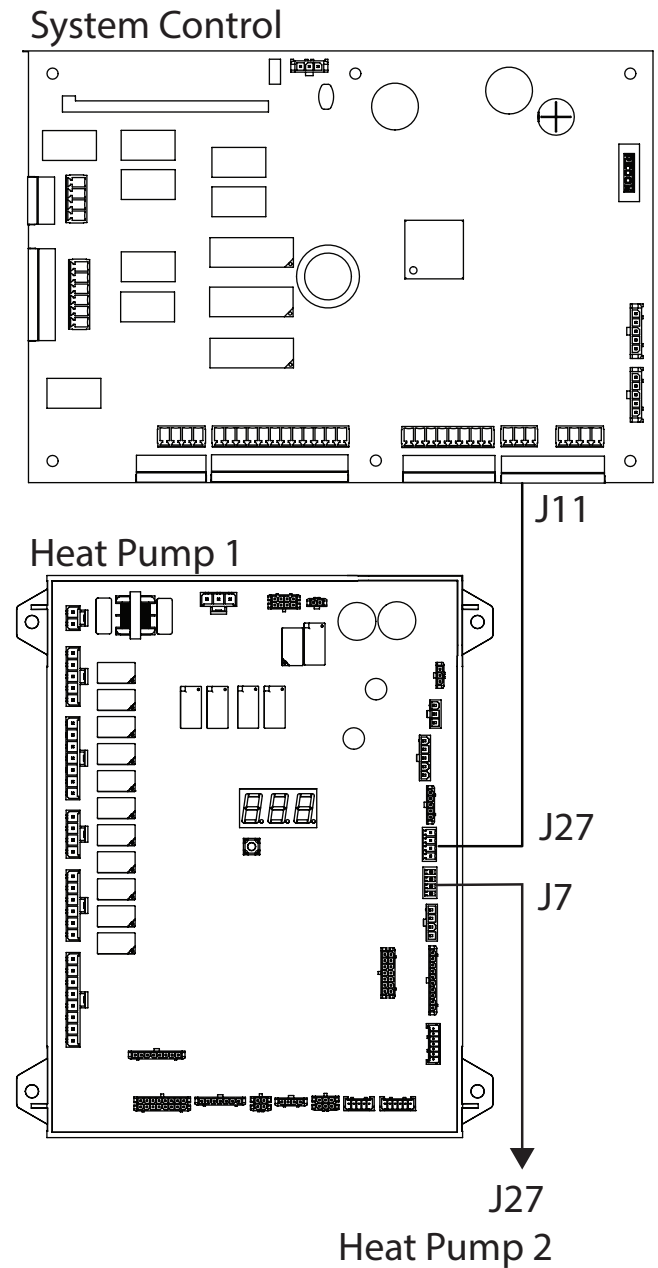

7 Field Wiring

Figure 7-5 System Control Board Wiring Connections

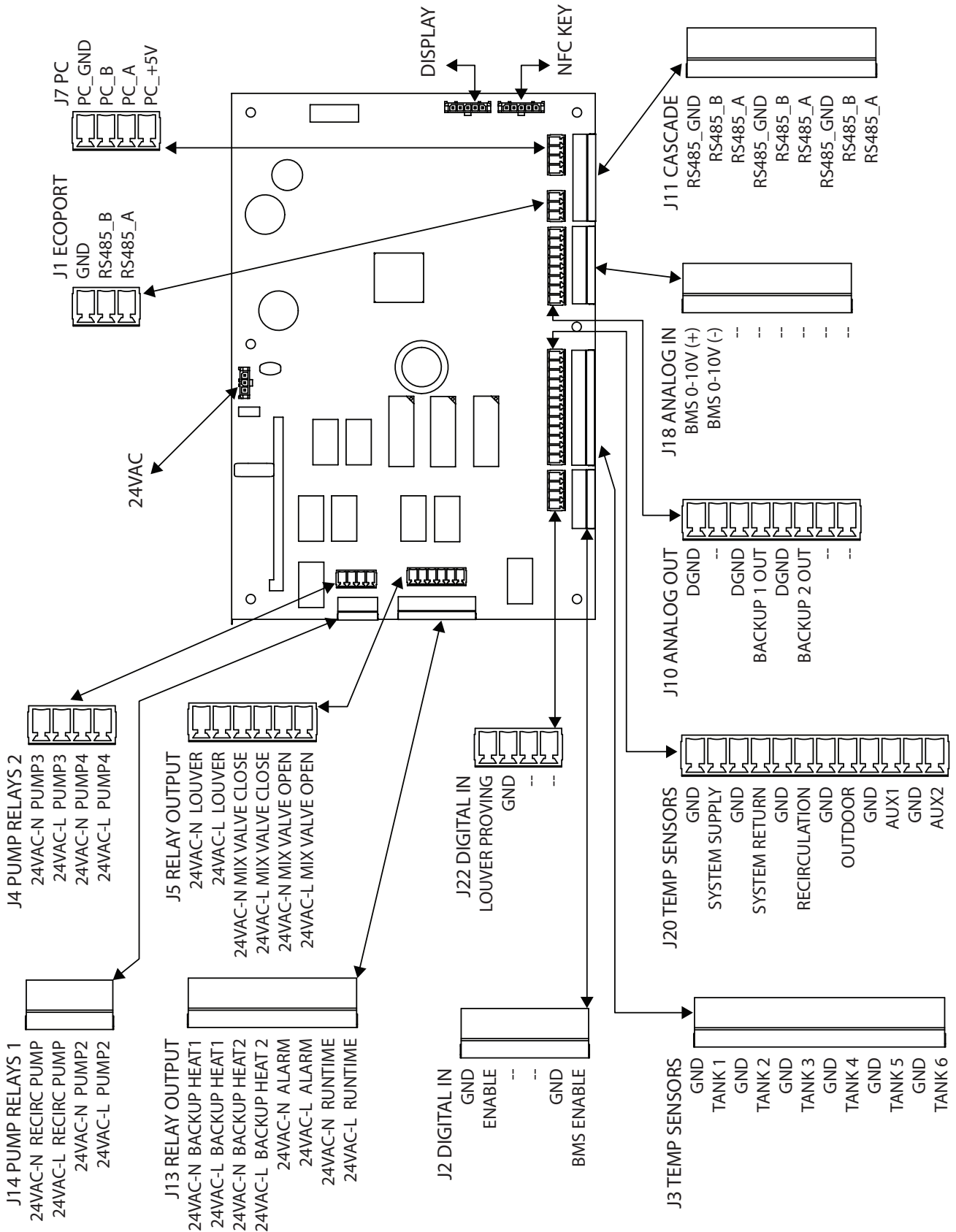

8 Installation Checklist

The list below represents some of the most critical installation requirements that, when overlooked, often result in operational problems, down time and needless parts replacement. This is not a complete list. Before performing any troubleshooting procedures use the list below to check for installation errors. Costs to correct installation errors are not covered under the limited warranty. Ensure all installation requirements and instructions in this manual have been followed.

Location

1. Ensure the HPWH is located where there is a adequate supply of ambient heat for optimal performance or that the HPWH is ducted to such a location.
2. Ensure required clearances are maintained and there is access for servicing. See Clearances on page 17.
3. Ensure the HPWH is properly supported.

Air Flow & Ducting

4. Ensure all supply and return ductwork connected to the HPWH is properly sized, does not exceed maximum equivalent length requirements. Consult the factory for sizing.
5. Ensure all supply duct work is insulated to prevent condensation from forming on the ductwork.
6. Ensure all return air duct is insulated if the return air temperatures are expected to fall below the surrounding room air temperature during normal operation.

Water Piping

7. Ensure the outlet (supply) and inlet (return) water piping connected to the HPWH are not less than the connection size on the unit.
8. The unit pumps will perform best if check valves are not installed between the heat pump outlet and tank unless required by code on the system diagrams. The ball valve internal to the unit can prevent hot water short circuiting.
9. When the HPWH is connected to a storage tank ensure the storage tank is equipped with a properly rated and sized Temperature and Pressure (T&P) relief valve. Refer to the storage tank manufacturer's instructions for T&P valve sizing and installation requirements.

Note: This is a critical installation requirement that must not be overlooked. Call the toll free technical support phone number 1-800-722-2101 for further assistance.

10. DO NOT install a T&P valve in the outlet (supply) water line of the HPWH unless required by local code.
11. Ensure isolation valves are installed on the HPWH supply and return water line at the storage tank for servicing and purging the air from the HPWH during start-up.

12. Tee into the inlet of the HPWH, but in some cases piping directly to the tank is possible. See the Service and Installation Notes for Inlet & Outlet Water Temperature on page 24.
13. Connect building recirculation loop piping to the backup water heater inlet on two tank preheat piping configurations.
14. Ensure the building recirculation loop pump is controlled by a field supplied line thermostat and that it stops the pump when the recirculation line temp exceeds the manufacturer's specifications.
15. The manufacturer recommends installing a strainer at the inlet water line on the HPWH to help prevent scale build up in the heat exchanger. Service costs to clear blockages from the HPWH unit's heat exchanger due to debris are not covered under the limited warranty.

Condensate Drain

16. Ensure there is a water trap installed in the condensate line at the HPWH. Condensate will not drain without a water trap.
17. Ensure the condensate drain is properly connected to the HPWH and draining freely to a suitable floor drain or condensate lift pump that discharges condensate to a remote location. See Condensate Drain Line on page 24.

Electrical

18. BEFORE ENERGIZING THE UNIT ensure the power supply voltage and phase matches the requirements on the HPWH rating label. Damage resulting from applying the wrong voltage or phase is not covered under the limited warranty.
19. Ensure the power supply breaker or the fuses disconnect switch are within the requirements for the unit as shown on the HPWH rating label.
20. Ensure the power supply wiring meets the MCA (Minimum Circuit Ampacity) requirements shown in this manual and on the HPWH data label.
21. Ensure the HPWH is properly grounded according to the instructions in this manual and local code requirements.
22. Ensure the power supply connections to the HPWH are connected properly and securely tightened.
23. Ensure all electrical connections in the HPWH control panel are securely tightened.
24. When the factory supplied temperature sensor is used:
 - Insure the sensor is installed properly.
 - Ensure the temperature sensor has been installed in a designated temperature control opening in the mid/lower portion of the storage tank.
 - Ensure the supplied temperature sensor is coated with a suitable heat transfer compound (paste).

9 Start-up

3 Phase Start-Up Procedures

1. Make sure the disconnect is off and confirm there is no power on the distribution block on the electrical panel.
2. Pull the unit fuses from the fuse block in the back panel of the unit.
3. With disconnect back on, check and make sure the power at the distribution block is the same as the power requirements on the data sticker that is on the electrical panel.
4. Turn power off and reinstall fuses.

Final checks before starting the water heater

- Read the Water Heater Service Manual to familiarize yourself with SMART TOUCH control module operation. Read the preceding Start-up sections in this manual, for proper steps to start the appliance.
- Verify all the pre-check procedures have been completed.
- Verify the appliance and system are full of water and all system components are correctly set for operation.
- Verify electrical connections are correct and securely attached.
- Inspect vent piping and air piping for signs of deterioration from corrosion, physical damage, or sagging. Verify air piping and vent piping are intact and correctly installed per this manual.

Check system and water heater

- Check water piping
 1. Check system piping for leaks. If found, shut down the water heater and repair immediately. (See WARNINGS on pages 59 and 60 (start-up) regarding failure to repair leaks.)
 2. Check Delta T. Reference Section 4 - System Piping of this manual for more information regarding Delta T.
 3. Vent any remaining air from the system using manual vents. Air in the system will interfere with circulation and cause heat distribution problems and noise.
- Check vent ducting and air piping.
 1. Check seal at every connection, seam of air piping, and vent piping.

Check/control Water Chemistry

NOTICE

Conduct water quality testing prior to installing the appliance. Various solutions are available to adjust water quality.

See the following table for properly operating the water heater with the appropriate water chemistry. Good water quality will help extend the life of the appliance by reducing the effects of scale buildup and corrosion.

Table 9-1 Water Chemistry

WATER CHEMISTRY		
Specification	Range	Requirement
Hardness	< 5 gpg	Follow recommendations detailed below (See Notice 3)
	> 15 gpg	Water softening system required (See Notice 4)
Dissolved Solids	< 350 ppm	Hardness level must be met
pH Level	6.5 to 8.5	Acceptable range
Chloride	< 150 ppm	Acceptable range

NOTICE

1. Do not use the water heater to directly heat swimming pool or spa water.
2. At initial fill and during water heater start-up and testing, check system thoroughly for any leaks. Repair all leaks before proceeding further.
3. When water hardness levels are less than 5 gpg or 85.5 mg/l, the following is recommended:
 - a. Flush and clean existing water heating system prior to installation.
 - b. Inspect and, if necessary, replace the anodes in any existing tanks.
 - c. Install a Y-strainer on the inlet of each water heater as detailed in Section 7.
 - d. Limit the run time of the hot water recirculation loop.
 - e. Filter the hot water recirculation loop to a level of 10 microns. CAUTION: Check recirculation pump size to verify it is sized for filter addition.
4. When water softener is required, a Template Assisted Crystallization system is recommended.

9 Start-up *(continued)*

Initial Start-up

1. Before applying power, check all electrical connections. Tighten if necessary.
2. Verify electrical installation. Power requirements and branch circuit disconnecting must match equipment nameplate specifications.
3. Make sure the system is flushed and purged of air. Remove and clean any strainers or filters if necessary.
4. Make sure the sensor for the temperature control is securely mounted in the water tank bulbwell for proper temperature control.
5. Start the heat pump by turning the switch in the high voltage box to the ON position.
6. The crankcase heater is powered when the unit power is turned on, and should be on for 4 to 6 hours before allowing the compressor to start.
7. Double check to make sure all the air is out of the water line so the heat pump doesn't get air bound.
8. Pump Test – You should be able to hear the water flowing through the system. If not, there is a good chance the system is air bound and the air needs to be removed before starting the compressor.

CAUTION

OIL DILUTION! Bearing malfunction! It is important to ensure that new compressors are not subjected to liquid abuse. Turn the crankcase heater on 4 - 6 hours before starting the compressor.

CAUTION

High discharge pressure operation! Compressor damage! Do not use compressor to test opening set point of high-pressure cutout. Bearings are susceptible to damage before they have had several hours of normal running. Liquid and high pressure loads could be detrimental to new bearings. It is therefore important to ensure that new compressors are not subjected to liquid abuse and high-pressure run tests.

Display Panel Startup

1. Display control panel can be mounted on the side of the unit or in an equipment room (maximum distance from heat pump is 400 meters), and requires a 120VAC single phase 60 hertz power source.
2. Connect the communication harness to the system board. This cable runs from the display panel to the control panel inside the HPWH control panel in the unit. This communication harness will be provided in a length that will connect if the display is mounted to the side of the unit, but for installation that require longer harnesses connectors will be provided to make the harness the length needed.
3. For more than one unit, an additional communication cable will need to be installed between the 2 units, so the system board inside the display panel can communicate with all HPWHs linked together. This harness will be provided if HPWH's are positioned next to each other up to 12 inches apart.
4. Display control panel houses the system control board that has connections for up to 6 tank sensors. Install the tank temperature sensors in a designated temperature control opening in the mid/lower portion of the storage tank.
5. Use a suitable heat transfer compound on the probe to ensure an accurate temperature reading.
6. Check the voltage into the terminal block and make sure that it is 120V before applying power to the display panel.

Commissioning Mode

Upon the initial startup, each heat pump will be forced to step through a three-step commissioning sequence to help ensure proper installation and operation. Each step must be acknowledged by the user by holding the button on the unit control box for 5 seconds. The three-character LED on the heat pump control board will display SR1, SR2, or SR3 depending on which step of commissioning mode is currently active.

1. SR1 - System Prime – The water valve will be set to fully open without the pump running. This is to help charge water to the system and remove any air.
2. SR2 - Manual Flow – The pump will run at the highest flow set point. The flow rate cannot be changed during commissioning. Check for any system water leaks.
3. SR3 - Manual Run – Water heating will be requested, and the unit will run at 160°F (71°C). Verify proper temperatures and pressures.

After advancing past step three, the unit will be set to normal operation.

9 Start-up

Rotation Direction

Scroll compressors, like several other types of compressors, will only compress in one rotational direction. Three-phase compressors will rotate in either direction depending upon phasing of the power to L1, L2 and L3. Since there is a 50/50 chance of connecting power in such a way as to cause rotation in the reverse direction, it is important to include notices and instructions in appropriate locations on the equipment to ensure proper rotation direction is achieved when the system is installed and operated. Observing that suction pressure drops and discharge pressure rises when the compressor is energized allows verification of proper rotation direction. There is no negative impact on durability caused by operating three-phase Copeland Scroll™ compressors in the reversed direction for a short period of time, (under one hour), but oil may be lost.

After a few seconds of operation in reverse, the compressor Core Sense system will lockout due to reversed phase. However, if allowed to repeatedly restart and run in reverse without correcting the situation, the compressor will be permanently damaged. All three-phase Scroll compressors are identically wired internally.

If the CoreSense locks out with a compressor reversed phase fault, switch two legs of incoming 480VAC power at the main connections into the HPWH at the rear of the unit.

Starting Sound

During the very brief start-up, a clicking sound is audible, resulting from initial contacting of the spirals and is normal. No start assist devices are required for three-phase compressors, even if a system uses non-bleed expansion valves. Due to the design of the Copeland Scroll, the internal compression components always start unloaded even if system pressures are not balanced. In addition, since internal compressor pressures are always balanced at start-up, low voltage starting characteristics are excellent for Copeland Scroll™ compressors. Moreover, if low voltage conditions exist at start up, protector trips could result.

Start-up

This start-up refers to several tools and test instruments needed to complete the procedure. See Required Tools and Materials on page 22.

1. Ensure the Installation Checklist has been completed.
2. Ensure the HPWH, storage tank and water system has been purged of air and all valves are in the position for normal operation.
3. Turn on power at the circuit breaker or disconnect switch serving the HPWH.
4. Turn the power switch on inside the display panel to monitor the refrigerant pressures, the inlet water temperature, and the outlet temperatures to ensure water temperature is rising.

NOTE: It may be helpful to record the operating data initially every 10 to 30 minutes just to see how the heat pump is performing.

5. The factory temperature setting is 120°F. Refer to page 50 for adjusting setpoint. (This can be adjusted later as well, NEVER SET HIGHER THAN 160°F).
6. The unit is equipped with inlet and outlet water sensors. Their values will be displayed on the display screen. Ensure the water outlet (supply) and inlet (return) valves are fully open. Start the HPWH and allow it to operate for 5 minutes. With the HPWH operating record the inlet and outlet temperatures.

During normal operation, the outlet line should be 8°F to 120°F (4°C to 67°C) hotter than the inlet line. This is the temperature rise through the heat exchanger inside the HPWH unit. Note: Temperature rise and water flow rate through the heat exchanger inside the HPWH are uniformly linked. As water flow is decreased the temperature rise will increase and as water flow is increased the temperature rise will decrease. Because of this relationship between temperature rise and flow rate this test can be useful to determine if the flow rate through the heat exchanger is adequate. Other factors may also affect water flow rate and temperature rise such as debris or lime scale build up inside heat exchanger or water pump operation.

If the temperature rise through the HPWH is consistently lower than 8°F, check the display screen to verify flow. If the temperature rise continues to be excessive call the toll free technical support phone number: 1-800-722-2101.

9 Start-up *(continued)*

If the HPWH does not start immediately:

- Wait 10 minutes in case the anti short cycle timer has halted operation. This control system feature protects the HPWH from rapid short cycling that can cause permanent damage to the unit.
- Ensure the operating set point on the tank temperature control is adjusted high enough to initiate a call for heat.
- DO NOT set the operating set point on the tank temperature control above 160°F. See Water Temperature Range on page 14.
- Ensure the differential set point is not set too high. Higher differential settings will cause greater temperature swings in system temperature. Lower differential settings can cause unit short cycling. The recommended setting is 10°F.
- If the unit does not start after all of the above procedures have been followed. Refer to the troubleshooting section of this manual.

7. Using thermometers or temperature sensors, measure the temperature of the return (inlet) air to the HPWH and the supply (outlet) air leaving the unit. The outlet air temperature should be 12°F to 20°F (7°C to 11°C) cooler than the inlet air. Air temperature and flow rate through the heat pump determines what this temperature difference will be. The higher the flow rate the lower the temperature differential will be. The higher the air temperature, the higher the differential will be.

If the temperature differential between return and supply air is not within the range stated above ensure the air filters are clean and there is nothing blocking the air flow on either side of the air stream or ductwork attached to the HPWH. Ensure the ductwork is not smaller than the minimum required size and or longer than the maximum length allowed in the Air Flow & Ducting section of this manual. Ensure the evaporator coil is not damaged (fins flattened) or dirty. If the temperature differential continues to be outside the range mentioned above call the toll free technical support phone number 1-800-722-2101 for further assistance.

8. When all of the above procedures are complete adjust the tank temperature control set point to desired system temperature, not to exceed 160°F (71°C). Remove all test instruments and replace all cabinet door.

9 Start-up

Adjust set point temperature(s)

During normal operation, set point temperatures can be adjusted from the Home Screen by pressing the SETPOINT button in the middle of the screen (see FIG. 10-1).

1. To change a set point, use the pull down list to adjust the set points as shown in FIG. 9-1.
2. Once the set point has been adjusted to the desired setting, press the SAVE SETPOINTS dialog box (right).

NOTE: The SAVE SETPOINTS dialog box must be pressed to complete programming of the controls. Failure to press the SAVE SETPOINTS dialog box will result in an unprogrammed control. The Door Menu button will become highlighted when there are changes that can be applied.

3. Follow the same steps to set the tank temperature (Figure 9-2).

Set clock

The SMART TOUCH control has a built-in clock that it uses for its night setback feature and for logging events. This clock must be set when the appliance is installed and anytime the appliance has been powered off for more than one day. Use the following procedure to set the clock:

1. Press the SETTINGS button (gear icon) at the top center of the screen (see Figure 9-1).
2. Press the SET APPLIANCE TIME button across from the date and time.
3. Proceed to set the date, time, and time zone. **NOTE:** Automatic Time Zone will not work.
4. Temperature units and WiFi may also be set here. These items may be used to automatically sync the time.
5. Press the HOME button to exit.

Figure 9-1 User Set Point Screen



9 Start-up *(continued)*

Figure 9-2 User Set Point Screen



Configuration of the cascade

Configuration of the cascade will happen automatically on start up. The system control board will assign addresses to each unit on initial startup. This will enable cascading of the heat pumps.

10 Operating Information

General

How the water heater operates

The water heater uses a scroll compressor to compress low pressure vapor refrigerant to a high pressure vapor state. The high pressure vapor is passed through a brazed plate heat exchanger along with cold water that passes through the heat exchanger in channels flowing in the opposite direction. The heat from the refrigerant is used to heat up the water and refrigerant returns to a liquid state. The amount of the liquid refrigerant flow is metered by electronic expansion valves (EEVs) as it enters 2 evaporators where air forced through the evaporators heats the refrigerant enough to change it back into a vapor. The vapor refrigerant returns to the compressor where the cycle starts over.

Defrost

In low ambient temperatures, the unit has the ability to reverse refrigerant flow using the 4 way valve. There are sensors located on the evaporators that allow the unit to know when defrost is needed. When this occurs, the 4 way valve directs the hot refrigerant from the compressor straight to the evaporators reversing the flow. When the evaporators have reached the desired temperature that indicates all frost has melted, the fan runs for a short amount of time to allow things to dry. Once this time has elapsed the 4 way valve switches positions and the unit goes back to normal operation.

Control inputs and outputs

Tank thermostat / tank sensor

Either of these inputs will tell the water heater to provide heat to the water tank.

0 - 10VDC input (set point)

The water heater can be controlled by a Building Management System (BMS) using a 0 - 10 VDC signal. The control can be configured by the installer to use this signal to either control set point. This signal can be sent to the heater through ModBus as well.

Temperature control

Water Flow

The water heater water flow is controlled to produce water to a given set point. The flow will vary as water temperature, ambient air temperature and set point change.

Vacation Mode

This mode is used to reduce temperature setpoint by the vacation offset while the building is not occupied. If enabled the tank setpoint temperature will be reduced by the amount specified by the Vacation Offset Temperature.

If Vacation mode is active an icon on the home screen will appear under the tank setpoint location with the word VACATION.

Night setback

Night Setback allows tank temperatures to be offset (lowered) during periods where the building is either unoccupied or seasonal use allows lower temperatures. Twelve schedules will allow the user to customize systems to maintain comfort while conserving energy during low-demand periods. From this screen you can enable/disable by pressing the enable check box for the listed schedule. If a schedule is active, an icon on the home screen will appear under the tank setpoint location with the words NSB#, where # is the active schedule. Night Setback Schedules can be added or edited by pressing the Edit Schedule Icon or Add Schedule button. Toggle through the month, days, days of the week, and time to set the schedule.

Protection features

Outlet temperature, ambient temperature, and refrigerant pressures

The outlet temperature is monitored by the water heater outlet temperature sensor. When the outlet temperature exceeds 170°F, the control will shut the unit down until the temperature drops 5°F.

The control module monitors the air temperature by a sensor located inside the unit. As the air temperature rises the control module reduces the fan speed. When the air temperature exceeds 120°F the control will shut the unit down. The unit will restart automatically once the air temperature drops 10°F (6°C) and the minimum off time has expired.

The refrigerant pressures are monitored at the suction and discharge pipes of the compressor. The discharge pressure switch opens at 400 psig shutting the compressor off, and when the pressure drops to 280 psig or lower, the switch closes to allow the compressor to run. Low pressure is limited on the inlet or suction side of the compressor. If the pressure drops to 5 psig, the switch opens and the compressor shuts off. When pressure reaches 20 psig on the line, the switch opens and the compressor is once again allowed to run. The compressor will also lockout at a high temperature on the discharge of 250°F. For operation to be allowed to resume the temperature must cool down for 20 minutes. If the refrigerant manages to reach the hard lock out temperature of 275°F, the oil will break down and must be replaced. The 140K unit Core Sense Module has a hard lockout at 260°F to prevent oil damage, but this feature is not available on the 60K unit.

10 Operating Information *(continued)*

Short Cycling

The heat pump has a built in “Anti-Cycle” to protect the compressor from starting too frequently. The compressor should remain off for at least three minutes after any period of running. Each unit will remain in “Anti-Cycle” state until this three minute timer has been cleared. The current state, including “Anti-Cycle,” can be seen on the display by navigating to the individual heat pump information screen.

Freeze protection

These units can be installed in conditions below 32 F. With power to the heat pump, the unit will circulate approximately 1.5gpm water flow through the system for freeze protection. Additionally, there are electrical heat trace cables on the water inlet pipe, condenser, and evaporator drain pan to aid in ice prevention.

⚠ DANGER Freezing Conditions: If this appliance may have been exposed to freezing conditions with no power, do not start the unit. Shut off power and water to the appliance immediately and contact the factory for further instructions. Allowing the appliance to start when the heat exchanger or near water heater piping is frozen will result in death or serious injury, and significant property damage.

The following integral feature of the appliance control module provides some protection for the appliance only -- not for the system.

The water heater control module provides freeze-up protection as follows:

- Below an inlet or outlet temperature of 40°F (4.4°C), the water heater pump operates constantly.
- Water pump will turn off if water inlet or outlet temperature rises above 45°F (7°C).

Neither this feature nor the water heater control module eliminates the possibility of freezing. The installation must still use recognized design, installation, and maintenance practice to prevent freeze potential for the appliance and system.

The Freeze Protection feature will not work if the appliance does not have power, is locked out, is in shutdown mode, had a component failure, or is otherwise prevented from firing.

Runtime and alarm outputs

The water heater provides dry contacts for indicating when the water heater is running, and when it is unable to operate.

Runtime and cycle counting

The control uses a timer to monitor the total hours of unit operation. The timer monitors the time the water heater is on.

The control uses a counter to monitor the amount of water heater cycles. The first counter counts compressor power on cycles.

Service reminder

The control can be programmed for service reminder notification. This notification will become active when either a set amount of time has expired, or a set amount of running hours or cycles has expired (all adjustable by the installer). The display will show a Maintenance Required screen. The installer’s name and phone number can be programmed into the control. This information will appear on the Maintenance Required screen. The service reminder notification can be reset or disabled by the installer.

The time dependent feature has been disabled by the manufacturer. To enable this feature change the parameter to the desired time interval, reference the Service Manual for details regarding parameters.

Error logging

The control will hold in memory the last 10 lockouts as well as the last 10 blockings. The date and time of the occurrence will be recorded as well. Only the 10 most current occurrences of each will be held in memory.

Water heater temperature regulation Operating temperature (target)

The SMART TOUCH control module senses water temperature and regulates water water and air flow to achieve a target temperature. The target temperature can be set between 120°F and 160°F.

High limit operations

The water heater is equipped with an automatic reset high limit and a manual reset high limit. The automatic reset high limit has a set point of 185°F from the factory and the manual reset high limit has a maximum set point of 200°F.

When the outlet temperature exceeds 170°F, the automatic high limit action occurs. The water heater shuts down until the outlet water temperature cools below 165°F, and a 60 second timer has expired. If the outlet temperature continues to increase, then the manual reset high limit switch action will occur at 203°F.

10 Operating Information

Low water cutoff protection

1. The SMART TOUCH control module uses temperature sensing of both supply and return areas of the heat exchanger. If the flow rate is too low or the outlet temperature too high, the control module shuts the water heater down. This ensures water heater shutdown in the event of low water or low flow conditions.
2. Some codes and jurisdiction may accept these integral features of the control in lieu of requiring an additional limit control or low water cutoff. Consult local jurisdiction to determine.

Cascade

When multiple water heaters are installed, they can be wired together in a cascade sequence. Multiple water heaters can be controlled from a single control. The system control board located in the display panel box will control all heat pumps to run in an optimized order to give all heat pumps an equal amount of run time.

Once the heat pump water heater receives a call for heat from a tank sensor or BMS, the control will determine what the set point will be. A fixed temperature set point can be programmed into the control. See page 49 of this manual to program the set point.

If the water temperature at the tank is less than the set point - differential, then the control will initiate a call for heat on the Cascade (see the Water Heater Service Manual for an explanation of the differential). The system control board will energize a heat pump(s) in the Cascade.

Sequence of the cascade

To equalize the runtime of all water heaters on the Cascade, the operating sequence will automatically be changed at set intervals.

For the first 24 hours after initializing the Cascade, the sequence will be changed every hour. After that the sequence will be changed once every 24 hours. For example, switching on/off sequence will be as follows for 8 HPWHs in the cascade:

If a water heater locks out, a different unit will be turned on instead.

Night Setback operation with cascade

Night Setback operation of the water heaters within the Cascade is available. Programming of the Night Setback will be done through the display. Refer to the Water Heater Service manual for information regarding Night Setback.

Access modes

User

The USER can set the tank set point, turn the unit OFF and ON, and set up Wi-Fi.

Installer

Most parameters are available only to the installer, accessible by entering the installer password, see the Water Heater Service Manual.

NOTE: The password will timeout after an hour from entry.

10 Operating Information *(continued)*

Sequence of operation

1.	Upon a call for heat, the control turns on the DHW pump.
2.	The control energizes the louvers (optional).
3.	The control confirms that the refrigerant high and low pressure switches, blocked drain switch, limits, louver proving switch (optional), and contacts close.
4.	The control confirms the fan comes up to the desired speed.
5.	Once the fan is at desired speed, cycle is complete, the control lowers the fan speeds, initiates compressor, and opens the water valve.
6.	Once the DHW call for heat is satisfied, the control will turn off the compressor. Any pumps that are running will begin their respective Pump Delay cycles.
7.	At the end of the pump cycle, the louver relay contacts will de-energize.
8.	At the end of the Pump Delay cycle(s), the pump(s) will be turned off.

10 Operating Information



The Home Screen displays basic information on how the unit is running. It is divided into the following sections: System Status, System Sensors, Heat Pump Status, and Navigation.

Figure 10-1 Home Screen



- The **System Status** Section is located on the top left of the screen and displays tank setpoints, BMS active or inactive, and the setpoint button for adjusting setpoint.
- The **System Sensor** Section is located on the top right of the screen and displays the outdoor air temperature, system supply temperature, building recirc line temperature, system return temperature, and 6 tank temperatures (system may not required all 6 tank sensors).
- The **Heat Pump Unit Status** Section is located on the bottom of the screen and displays operating information on the heat pumps connected to the system. This can be up to 64 heat pumps. Each heat pump block displays if the unit is currently running (i.e. run, stand-by, blocking, lockout), outlet temperature, inlet temperature, and flow rate in GPM.
- The **Navigation** Section is located in the top portion of the screen. There are five (5) sections located below the Lochinvar icon: Home, View, Setup, Information (About), and Settings. The Home Section is the screen shown above. The View Section provides more detailed information including subsections for: System Sensors, Runtime, Faults, and System Details. The Setup Section has several screens to aid in setting up the appliance. The Setup Section includes screens for adjusting: Set Points, BMS settings, Backup Heat Settings, Boost Settings, BAS Settings, Service Mode, Service Notification, and System Configuration. The Setting Section enables several interface setup features including: Temperature Units, Time Setup, WiFi Setup, Screen Settings, System Updates, and Terminal Reboot.

11 Maintenance

Maintenance and annual startup

Table 11-1 Service and Maintenance Schedules

Service technician (see the following pages for instructions)		Owner maintenance	
ANNUAL START-UP	General:		
	<ul style="list-style-type: none"> • Address reported problems • Inspect water heater area • Inspect interior; clean and vacuum if necessary; • Check for leaks (water, air) • Check water heater relief valve • Check system water pressure/system piping/expansion tank • Check control settings • Check wiring and connections • Clean and inspect evaporators • Check internal insulation • Clean condenser (brazed plate hex) • Check air flow • Check refrigerant charge by viewing temperatures, pressures, and superheat on the Smart Touch control • Check Delta T (Temperature Rise) 	Daily	<ul style="list-style-type: none"> • Check water heater area
		Monthly	<ul style="list-style-type: none"> • Check air piping • Check air and vent termination screens • Check relief valve • Check drain system • Check automatic air vents • Check Delta T (Temperature Rise) • Remove debris from Y-strainer per manufacturer's instructions • Check building recirculation filter (if filter required) • Check for and clean any debris or obstruction from birdscreens (if equipped)
		Every 6 months	<ul style="list-style-type: none"> • Check water heater piping (refrigerant and water) for leaks • Check and clean drain pan • Operate relief valve • Check water chemistry • Inspect fan blades

11 Maintenance

⚠ WARNING

Follow the service and maintenance procedures given throughout this manual and in component literature shipped with the water heater. Failure to perform the service and maintenance could result in damage to the water heater or system. Failure to follow the directions in this manual and component literature could result in severe personal injury, death, or substantial property damage.

⚠ WARNING

The water heater should be inspected annually only by a qualified service technician. In addition, the maintenance and care of the water heater designated in Table 11-1 and explained on the following pages must be performed to assure maximum water heater efficiency and reliability. Failure to service and maintain the water heater and system could result in equipment failure.

⚠ WARNING

Electrical shock hazard – Turn off power to the water heater before any service operation on the water heater except as noted otherwise in this instruction manual. Failure to turn off electrical power could result in electrical shock, causing severe personal injury or death.

⚠ WARNING

Should the unit have to be serviced with live electricity, only trained and qualified technicians should carry out the service. Failure to follow all of the safety warnings may result in serious injury or death.

Address reported problems

1. Inspect any problems reported by the owner and correct before proceeding.

Inspect water heater area

1. Verify that water heater area is free of any corrosive materials.
2. Verify that air intake area is free of any of the contaminants listed in Section 1 - Determine Water Heater Location. If any of these are present in the water heater intake air vicinity, they must be removed. If they cannot be removed, reinstall the air and vent lines per this manual and the Water Heater Service Manual.

Inspect water heater interior

1. Remove the front access cover and inspect the interior of the water heater.
2. Inspect for oil on the components and base which could indicate a refrigerant leak.
3. Vacuum any sediment from inside the water heater and components. Remove any obstructions.

Check all piping for leaks

⚠ WARNING

Eliminate all system or water heater leaks. Leaking water may cause severe property damage.

1. Inspect the condensate drain line, condensate PVC fittings, and condensate trap.
2. Look for signs of leaking lines and correct any problems found.

Air Ducting

1. Visually inspect the entire air venting system for blockage, deterioration or leakage. Repair any joints that show signs of leakage. Verify that the air inlet and outlet duct is connected and properly sealed.
2. Verify that water heater air discharge and air intake are clean and free of obstructions.
3. Verify that bird screens are clean and free of debris or obstruction.

Check water system

1. Verify all system components are correctly installed and operational.
2. Check the cold fill pressure for the system. Verify it is correct (must be a minimum of 12 PSI).
3. Watch the system pressure as the water heater heats up (during testing) to ensure pressure does not rise too high. Excessive pressure rise indicates expansion tank sizing or performance problem.
4. Inspect automatic air vents and air separators. Remove air vent caps and briefly push valve to flush vent. Replace caps. Make sure vents do not leak. Replace any leaking vents.

11 Maintenance *(continued)*

Check expansion tank

Expansion tanks provide space for water to move in and out as the heating system water expands due to temperature increase or contracts as the water cools. Tanks may be open, closed or diaphragm or bladder type. See Section 4 - System Piping for suggested best location of expansion tanks and air eliminators.

Check relief valve

1. Inspect the relief valve and lift the lever to verify flow. Before operating any relief valve, ensure that it is piped with its discharge in a safe area to avoid severe scald potential. Caution should be taken to ensure that (1) no one is in front of or around the outlet of the temperature pressure relief valve discharge line, and (2) the water manually discharged will not cause any bodily injury or property damage because the water may be extremely hot.

WARNING

Safety relief valves should be re-inspected **AT LEAST ONCE EVERY THREE YEARS**, by a licensed plumbing contractor or authorized inspection agency, to ensure that the product has not been affected by corrosive water conditions and to ensure that the valve and discharge line have not been altered or tampered with illegally. Certain naturally occurring conditions may corrode the valve or its components over time, rendering the valve inoperative. Such conditions are not detectable unless the valve and its components are physically removed and inspected. This inspection must only be conducted by a plumbing contractor or authorized inspection agency – not by the owner. Failure to re-inspect the water heater relief valve as directed could result in unsafe pressure buildup, which can result in severe personal injury, death, or substantial property damage.

WARNING

Following installation, the valve lever must be operated **AT LEAST ONCE A YEAR** to ensure that waterways are clear. Certain naturally occurring mineral deposits may adhere to the valve, rendering it inoperative. When manually operating the lever, water will discharge and precautions must be taken to avoid contact with hot water and to avoid water damage. Before operating lever, check to see that a discharge line is connected to this valve directing the flow of hot water from the valve to a proper place of disposal. Otherwise severe personal injury may result. If no water flows, valve is inoperative. Shut down the water heater until a new relief valve has been installed.

2. After following the above warning directions, if the relief valve weeps or will not seat properly, immediately close the cold water inlet to the heat pump, follow the draining instructions in the storage tank manual, and replace the relief valve with a new one. Ensure that the reason for relief valve weeping is the valve and not over-pressurization of the system due to expansion tank waterlogging or undersizing.

Read Section 4 - System Piping before proceeding further. If you do not understand these instructions or have any questions regarding the temperature-pressure relief valve call the toll free number 1-800-722-2101 for technical assistance.

Check all water heater wiring

1. Inspect all water heater wiring, making sure wires are in good condition and securely attached.

Check control settings

1. Set the SMART TOUCH control module display to Parameter Mode and check all settings. See Section 1 of the Service Manual. Adjust settings if necessary. See Section 1 of the Service Manual for adjustment procedures.
2. Check settings of external limit controls (if any) and adjust if necessary.

Perform start-up and checks

1. Start water heater and perform checks and tests specified in Section 9 - Start-up.
2. Verify cold fill pressure is correct and that operating pressure does not go too high.

Review with owner

1. Emphasize the need to perform the maintenance schedule specified in this manual.
2. Remind the owner of the need to call a licensed contractor should the water heater or system exhibit any unusual behavior.
3. Remind the owner to follow the proper shutdown procedure and to schedule an annual start-up.

11 Maintenance

Evaporator Cleaning and Inspection

⚠ WARNING

Read all of the warnings provided for the cleaning products used for refrigeration coil cleaning. Follow all instructions for personal protection and safe application of the products. Before cleaning the evaporator, disconnect all power to the unit and follow the prescribed lock-out/tag-out procedure.

Inspect the evaporator coil for dirt buildup or fin crush on at least once per year. If there are signs of fin fold over, use a fin comb to straighten the fins. Should the coils need cleaning, follow the steps listed below:

Warning: Read all of the warnings on the bottle of the cleaning products used for evaporator cleaning. Follow all instructions for personal protection and safe application of the products. Before cleaning the drain pan or evaporators, disconnect all power to the unit and follow the prescribed lock-out/tag-out procedure.

⚠ CAUTION

Direct stream of water should be avoided, to prevent damage to evaporators. Instead using a fanned-out method.

1. Disconnect all power to the unit and follow the prescribed lock-out/tag-out procedure.
2. Wear the prescribed personal protective equipment prescribed from the cleaning product instructions.
3. Install a block-off sheet to prevent splash over into the dry sections of the HPWH.
4. Prepare the cleaning solution as prescribed from the cleaning product instructions and fill the mixture into a high-pressure sprayer.
5. Start spraying both sides of the coil keeping the nozzle perpendicular to the coil at least 6 inches from the coil face. If the water pressure is questionable, observe the impact of cleaning on a small section of coil before implementing universally.
6. Thoroughly rinse the cleaned coil with cool, clean water.
7. Straighten out any fins displaced during the cleaning using a fin comb.
8. Confirm the drain pan line is not clogged.
9. Replace all panels on the unit and wipe down any standing cleaning solution or water on or around the unit.

Cleaning Internal Pipe Insulation

Inspect the internal pipe insulation on a yearly basis for any microbial growth. The insulation never has to be cleaned unless microbial growth is detected. If microbial growth is detected, follow the removal steps below:

1. Disconnect all power to the unit and follow the prescribed lock-out/tag-out procedure.
2. Wear the prescribed personal protective equipment prescribed from the cleaning product instructions.

3. Remove as much dirt and organic material from the insulation using a vacuum device with a HEPA filter (99.97% efficient at 0.3 micron particles). Be careful not to tear the insulation during the cleaning procedure.
4. Apply the microbial cleaning agent as prescribed by the application and usage instructions.
5. Allow the unit to dry thoroughly.
6. If necessary, apply an anti-microbial agent on the insulation per the instructions provided on the product label. Discard collected microbial contaminants as required by local or state codes.

Drain Pan

Warning: Read all of the warnings on the bottle of the cleaning products used for drain pan cleaning. Follow all instructions for personal protection and safe application of the products. Before cleaning the drain pan, disconnect all power to the unit and follow the prescribed lock-out/tag-out procedure.

The condensate pan and drain line must be checked for cleanliness, growth, and blockage at least every six months. To clean the drain pan, start by disconnecting the power to the unit. Find a cleaner that is safe to use on ABS plastics. Wear the appropriate personal protective equipment prescribed by the cleaning product instructions. Apply the cleaning solution, allow it to sit for prescribed amount of time, then rinse. Remove any particles that could potentially block the drain line.

Braze Plate Cleaning Instructions

In some applications the heat exchanger may be subjected to severe fluid conditions, including high temperature hard water conditions, causing accelerated scaling and corrosion rates, and will diminish performance.

It is important to establish regular cleaning schedules. A 5% solution of Phosphoric Acid or Oxalic Acid may be considered. Other types of solutions can be obtained from your local wholesaler. Make sure cleaning solution is applicable for stainless steel and copper and all directions are followed.

Do not heat solution. Be sure to flush heat exchanger with fresh water after cleaning using flush valves provided with manifolds. See Figure 11-1.

Figure 11-1 Braze plate



11 Maintenance *(continued)*

Inspecting Fan Assembly

Before performing any maintenance on the fan assembly, disconnect all power to the unit and follow the prescribed lockout/ tag-out procedure.

⚠ WARNING Allow time for fan capacitor dissipation which takes a few minutes. Failure to wait for capacitor to dissipate could result in electrical shock, causing severe personal injury or death.

During inspection, visually check the blades for wear or damage and replace as necessary. Inspect to confirm the center hub bolt holding blades is in place, and tighten to 10 FT-LBS. Clean the blades periodically as material buildup on the blades can cause an imbalance that may lead to bearing failure. Every six months visually inspect the fan motor. Clean off any dust, grease or oily buildup and vacuum out any cavities in the motor. Motors are permanently lubricated from the factory. It is not necessary to lubricate the motor upon start-up or lubricate as part of maintenance.

Check Air Flow

Correct any problems with air flow before checking the refrigerant pressures.

Checking Refrigerant Charge

Service of the refrigeration circuit must only be performed by agencies or individuals possessing Type II or Universal certification as defined in Section 608 of the Clean Air Act. See Qualifications on page 6.

This HPWH unit is factory charged with 513A refrigerant. See the rating label on the HPWH unit and Table 11-3 on page 61 for refrigerant charge by weight. It should not be necessary to add or remove refrigerant during installation or start up. Refrigerant lost during frequent refrigerant pressure testing can cause low refrigerant conditions. It is recommended that pressures, temperatures, and superheat values be taken from the smart control. Air and water flow should always be checked first to eliminate other potential problems before checking the refrigerant charge. Using gauges should be a last resort when troubleshooting refrigeration issues.

To check if the system is low on refrigerant, check the refrigerant pressures and compare it with the PT chart of 513A (Table 11-4). If there is more than 10 psi difference between the system pressures and saturated pressures, this might indicate a loss of charge in the system. In case of low charge in the system:

1. Reclaim the refrigerant to a recovery tank if possible.
2. Pressure-test the system with an inert gas like Nitrogen and monitor and system for leaks.
3. After pressure testing, pull a deep vacuum on the unit (< 500 microns; 350 microns recommended). Ensure the system holds the vacuum.
4. Weigh and charge the unit with the appropriate amount of refrigerant. See table 11-3 for the recommended amount.

Superheat

1. Use the display screen to record the ambient temperature and measured superheat.
2. Use Table 11-2 to verify that superheat is in range for the temperature.
3. Always refer to Smart Touch to monitor pressures, temperatures, and superheat to prevent using gauges.

Table 11-2 Superheat for Ambient Temperatures

Model 60K		Model 140K	
Temperature Ambient (°F)	Superheat (°F)	Temperature Ambient (°F)	Superheat (°F)
23 - 40	15 - 22	23 - 40	15 - 22
40 - 80	22 - 24	40 - 80	22 - 24
80 - 95	24 - 27	80 - 95	24 - 30
95 - 120	27 - 30	95 - 120	30 - 35

Check Water Temperature

Always check water temperature rise through the HPWH unit's internal heat exchanger before checking the refrigerant charge. See Start Up on page 46 for information on how to measure the water temperature rise.

If the measured water temperature rise during start up is at least 10°F (5.6°C) checking the charge is not necessary unless other conditions warrant testing.

If the measured temperature rise through the HPWH unit is less than 10°F (5.6°C) checking the charge is not necessary unless other conditions warrant testing. Short water piping runs between the HPWH and the storage tank will produce lower temperature rises and are not problematic.

If the measured temperature rise is more than expected, check for restrictions in the inlet and outlet water piping connected between the HPWH unit and the storage tank.

Table 11-3 Refrigerant Charge By Weight

Model	Factory Charge R513A
060	11.5 lbs
140	15 lbs

11 Maintenance

Table 11-4 Saturated Temperature Chart

R513A SATURATED TEMPERATURE CHART		
Saturated Temperature °F	Saturated Temperature °C	Saturated Pressure PSI
0	-18	9.1
5	-15	11.9
10	-12	15.0
15	-9	18.3
20	-7	21.9
25	-4	25.9
30	-1	30.1
35	2	34.6
40	4	39.6
45	7	44.8
50	10	50.5
55	13	56.5
60	16	63.0
65	18	69.9
70	21	77.3
75	24	85.1
80	27	93.4
85	29	102.0
90	32	112.0
95	35	121.0
100	38	132.0
105	41	143.0
110	43	155.0
115	46	167.0
120	49	180.0
125	52	193.0
130	54	207.0
135	57	222.0
140	60	238.0
145	63	254.0
150	66	271.8
155	68	289.9
160	71	308.9

11 Maintenance *(continued)*

Troubleshooting

Problem	Possible Causes	Corrections
<p>Heat Pump is too noisy</p>	<ol style="list-style-type: none"> 1. Sheet Metal fasteners are loose. 2. Operating vibration is transferring to floor or building structure. 	<ul style="list-style-type: none"> • Tighten Fasteners • Place vibration dampers underneath unit
<p>Water on floor around the heat pump and or water tank</p>	<ol style="list-style-type: none"> 1. Tubing, valves, or fittings are leaking. 2. Heat Pump is not leveled causing drain pan overflow 3. Condensate trap not installed properly 4. Drain pan overflowing 5. Condensation forming on the bottom of unit (humid environments) 	<ul style="list-style-type: none"> • Repair leaks as necessary • Shim unit to level, See installation section • Condensate trap depth must maintain a water column during operation • Use pipe snake or compressed air to remove obstruction • Cover bottom of unit with foam insulation
<p>Heat Pump is not running - Electrical issues</p>	<ol style="list-style-type: none"> 1. Circuit does not have adequate ampacity 2. Short circuit or loose connection in field wiring 3. Short circuit or loose connection in the cabinet 4. Thermostat failure 5. Compressor burn-out 	<ul style="list-style-type: none"> • Refer to nameplate for unit requirements • Check field wiring diagram, Tighten all connections • Check for loose wiring and tighten • Replace thermostat • Replace Compressor
<p>Heat Pump is not running - High Pressure Fault</p>	<ol style="list-style-type: none"> 1. Thermostat setting too high 2. Air temperature over 120° F 3. Low water flow causes: <ol style="list-style-type: none"> a. External Pump is not operating b. Piping between the heat pump and storage tank exceeds 500 equivalent feet c. Heat exchanger has scale buildup d. Shut off valves are partially closed 4. Faulty high pressure switch 	<ul style="list-style-type: none"> • Thermostat setting should not exceed 160° F • Keep heat pump off until room temperature is back in operating range • Low water flow corrections • Replace unit pump • Reduce piping or add booster pump • Clean heat exchanger with a mild acid wash • Open all shut off valves • Replace high pressure switch
<p>Heat Pump is not running - Low Pressure Fault</p>	<ol style="list-style-type: none"> 1. Room temperature below 23° F 2. Fan not operating at nameplate CFM 3. Flow though the evaporator is restricted or blocked. 4. Unit does not have adequate clearances obstructing air flow 5. Loss of Refrigerant 6. Faulty low pressure switch 7. Filer dryer restriction 8. EEV locked in closed position 	<ul style="list-style-type: none"> • Keep heat pump off until room temperature is back in operating range • Correct air-flow issue • Relocate unit to allow for even air flow • Find source of leak, repair, and recharge • Replace low pressure switch • Replace dryer filter • Clean or replace EEV

11 Maintenance

Troubleshooting continued

Problem	Possible Causes	Corrections
<p>Water is not reaching desired temperature</p>	<ol style="list-style-type: none"> 1. Thermostat setting is too low 2. Heat pump/storage tank undersized for application 3. Heat pump is not properly connected to storage tank 4. Unit cooling coil is over cooling the space 	<ul style="list-style-type: none"> • Set thermostat for storage tank to a higher temperature • Increase size of storage tank or install gas or electric heater to make up for shortfall • Refer to field piping diagrams for recommended piping • If the room air temperature is too cool: <ol style="list-style-type: none"> a) Use back up water heating b) Duct cool air to another space c) Duct warmer air from another space to the installed room
<p>Evaporator coil is icing</p>	<ol style="list-style-type: none"> 1. Insufficient air flow through the unit 2. Low air temperature 3. Partial refrigerant loss 4. Defective EEV valve 5. Clogged filter dryer 	<ul style="list-style-type: none"> • Refer to “Heat pump not running - low pressure fault” section for correction suggestions • If room air temperature is too cool <ol style="list-style-type: none"> a) Use back up water heating b) Duct cool air to another space c) Duct warmer air from another space to installed room • Find source of leak • Replace EEV valve • Replace filter drier

*Reset the heat pump by removing then restoring power to the unit at the breaker, from the manual switch, or by pressing and holding the button on the side of the control panel of the unit for 5 seconds. (There will be a three minute delay before heat pump restarts.) If the heat pump cuts out again on LOW or HIGH PRESSURE, additional troubleshooting is necessary to find the cause.

DO NOT CONTINUE TO RESET THE HEAT PUMP, AS CONTINUED SHORT-CYCLING MAY STRESS OR DAMAGE INTERNAL COMPONENTS.

12 Diagrams

Figure 12-1 Ladder Diagram

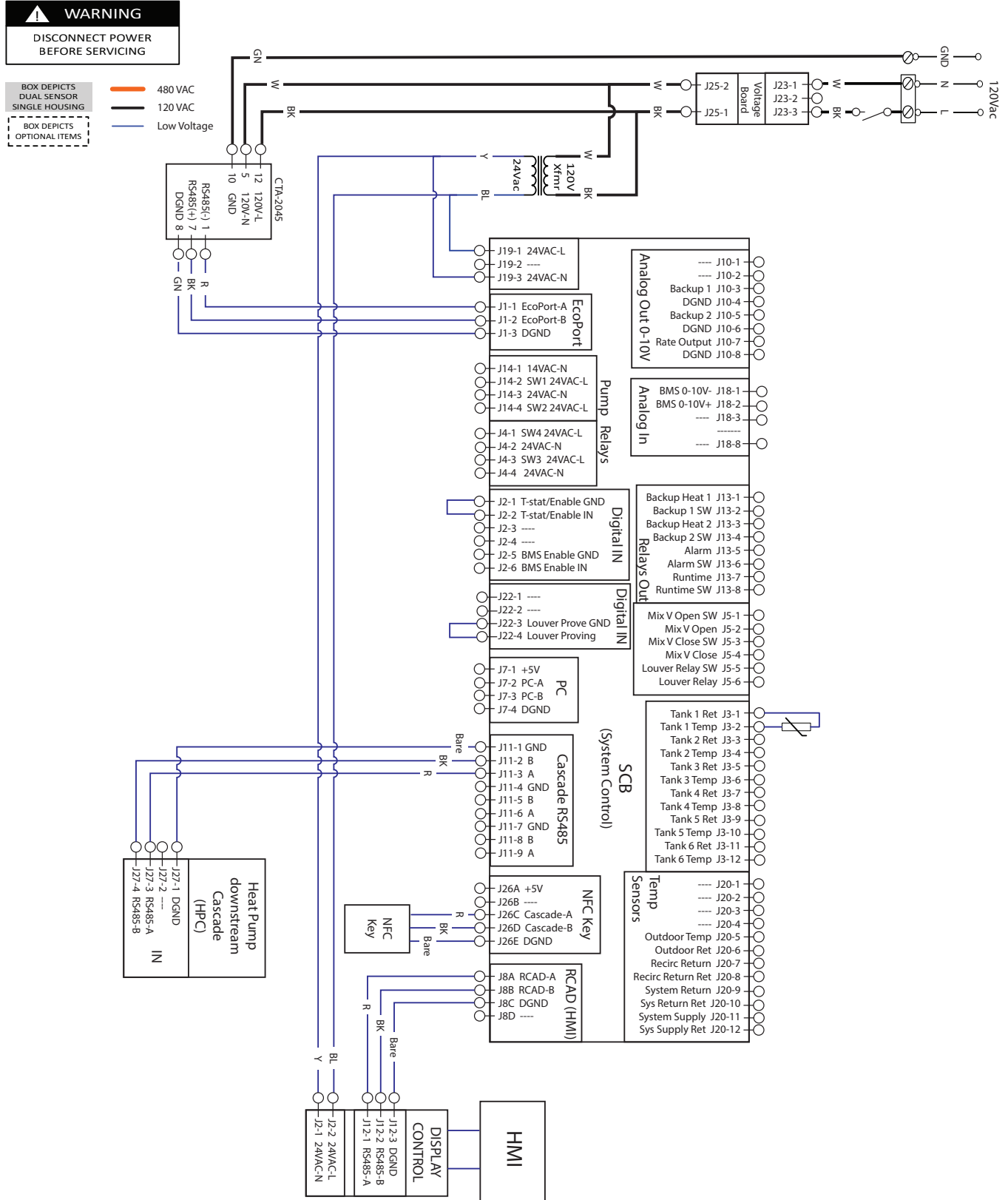

- NOTES:
1. All wiring must be installed in accordance with: local, state, provincial and national code requirements per either N.E.C. in USA or C.S.A. in Canada.
 2. If any original equipment wire as supplied with the appliance must be replaced, it must be replaced with wire having the same wire gauge (AWG) and rated for a minimum of 105°C. Exceptions: Replacement shielded cables must be purchased from the factory. Use of a non-approved wire or cable can lead to operational problems which could result in non-repairable damage to the integrated controller or other components.
 3. Actual connector block locations may vary from those shown on diagrams. Refer to actual components for proper connector block locations when using diagrams to troubleshoot unit.

12 Diagrams

Figure 12-2 Wiring Diagram

BOX DEPICTS DUAL SENSOR SINGLE HOUSING
 BOX DEPICTS OPTIONAL ITEMS

WARNING
 DISCONNECT POWER BEFORE SERVICING

480 VAC
 120 VAC
 Low Voltage

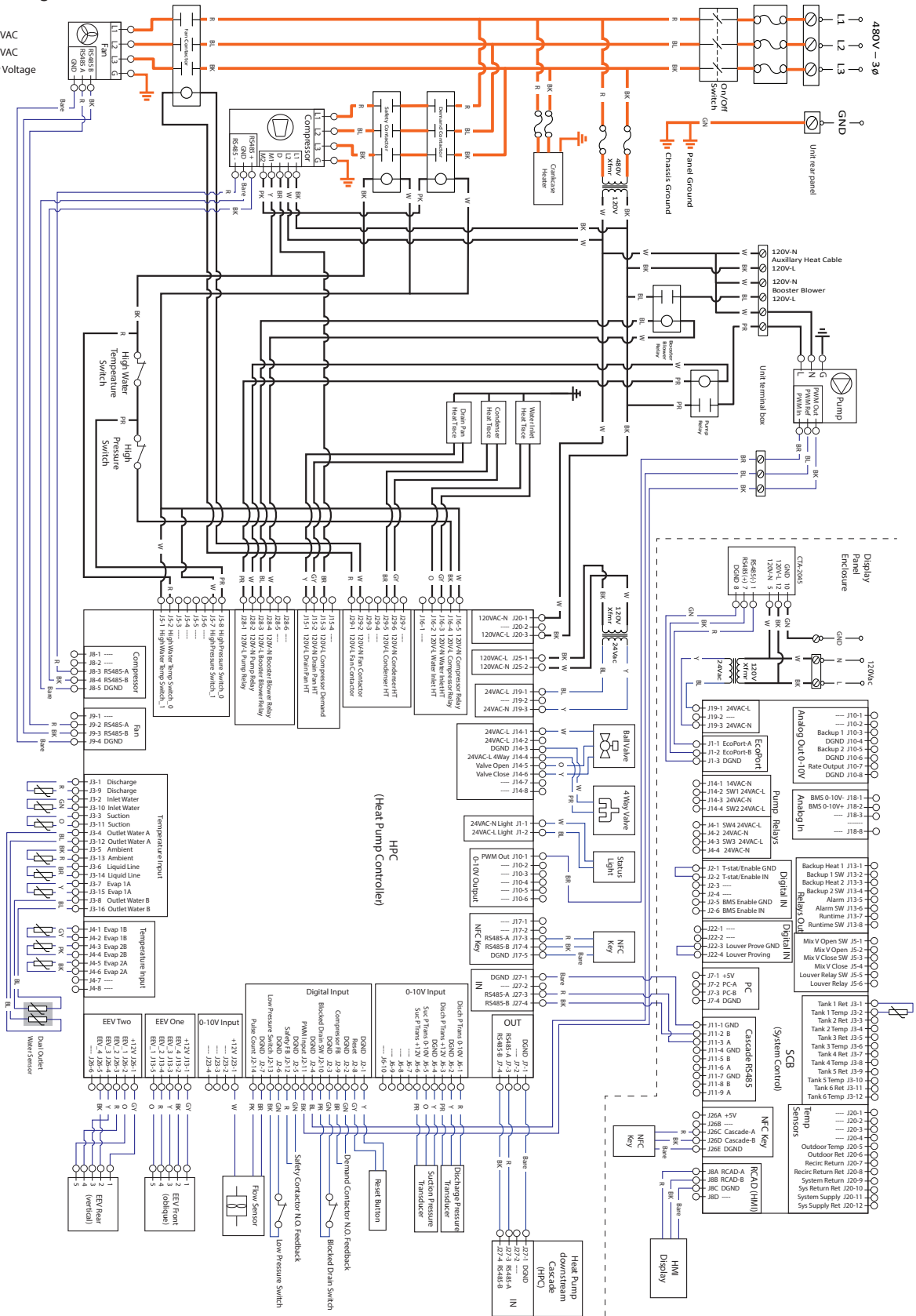

NOTES:

1. All wiring must be installed in accordance with local, state, provincial and national code requirements per either N.E.C. in USA or C.S.A. in Canada.
2. If any original equipment wire as supplied with the appliance must be replaced, it must be replaced with wire having the same wire gauge (AWG) and rated for a minimum of 105°C. Exceptions: Replacement shielded cables must be purchased from the factory. Use of a non-approved wire or cable can lead to operational problems which could result in non-repairable damage to the integrated controller or other components.
3. Actual connector block locations may vary from those shown on diagrams. Refer to actual components for proper connector block locations when using diagrams to troubleshoot unit.

Notes

Revision Notes: Revision A (PCP #3000057735/ CN #500043946)
initial release.
Revision B (PCP #30000 / CN #5000